



# Installation Instructions

Thank you for purchasing this anti-sway bar kit. Please read through these instructions before installation.

## Rear Anti-Sway Bar Kit Ford F350/450/550

part #1139-161  
1½" diameter



## INTRODUCTION

Thank you for purchasing this rear anti-sway bar kit. This kit is designed to improve the handling characteristics of your Ford F350/450/550 by reducing the body roll and balancing the weight transfer during cornering. The anti-sway bar kit is engineered for long life and trouble-free performance. For maximum suspension control, use this kit along with our front anti-sway bar kit.

## SUGGESTED TOOLS

The following tools are suggested to complete the installation procedures:

- General hand tools.

### **WARNING**

**Failure to follow these instructions can result in property damage, personal injury or even death.**

- If raising the vehicle to install the anti-sway bar, always support the vehicle with jack stands at both frame rails or at the rear axle before working underneath. Ensure that the jack stands are securely positioned, and are rated at or above the weight of the vehicle.
- The installer must read the instructions and use all bolts and parts supplied. Use only the parts supplied by ROADMASTER to install this kit.
- Minor modifications are sometimes necessary due to slight vehicle variations, even for the same year, make and model.
- Regardless of year, make and model, a wide range of options for specific applications may or may not interfere with the installation. It is the installer's responsibility to make certain that equipment is not damaged once the suspension solution travels through the full range of motion. Failure to ensure adequate clearance could result in non-warranty property damage, personal injury or even death.
- If running changes were made by the manufacturer after this kit was designed, there may be weldments, braces, gussets, or other structural items which interfere with the installation. It is the installer's responsibility to allow for these running changes without sacrificing the structural integrity of the anti-sway bar. Failure to securely fasten the anti-sway bar could result in property damage, personal injury or even death.
- ROADMASTER will not be responsible for any damage or injury resulting from any modification or alteration.
- Check ALL the fasteners for tightness before and after road testing the vehicle.
- Do not use this document for custom fabrication, as it may not show all parts or structural components.
- Do not use an air impact wrench when re-installing bolts, as stripped threads may result.
- This anti-sway bar is only warranted for the original installation. Installing a used anti-sway bar on another vehicle is not recommended and will void the warranty.

# PARTS LIST

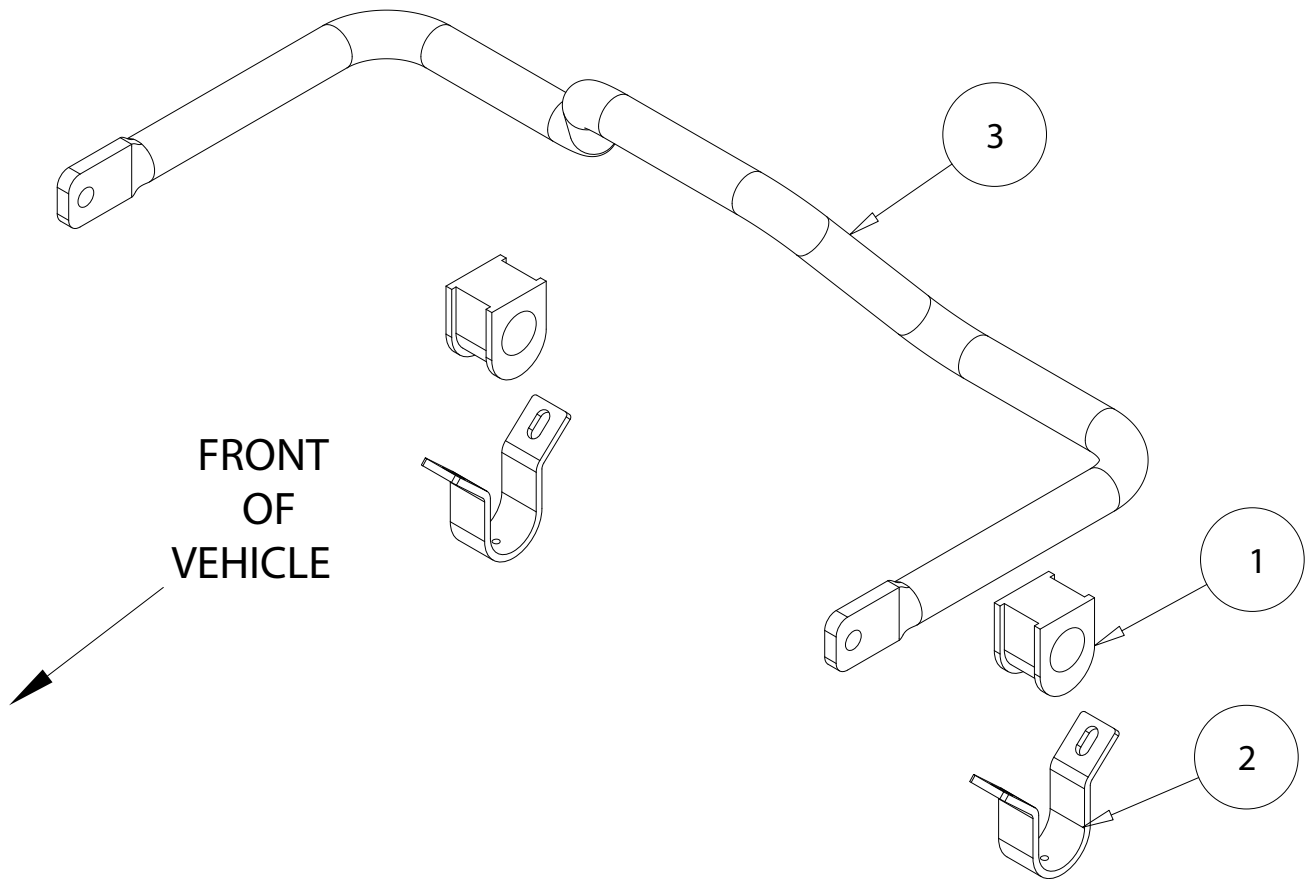

ITEM.....	QTY .....	DESCRIPTION .....	PART .....
1.....	2.....	SPLIT POLY BUSHING .....	205217-10
2.....	2.....	BUSHING CLAMP .....	B388
3.....	1.....	SWAY BAR .....	580027-00
4.....	1.....	AQUALUBE .....	400011-30

# INSTALLATION

**The following instructions must be followed in the order listed to ensure a proper installation and to preserve the ROADMASTER warranty.**

*Done with vehicle on ground.*

1. Remove the factory anti-sway bar.  
Undo the nut on each side attaching the endlinks to the ends of the anti-sway bar. Remove the two clamps that hold the anti-sway bar to the rear axle. Remove the anti-sway bar from vehicle.

## **WARNING**

Removing the clamps will release the anti-sway bar. The anti-sway bar is heavy, and may cause property damage or personal injury if it falls on equipment, engine components or any part of your body. Ensure that the anti-sway bar is supported and that you are out of the way when removing the brackets. Failure to follow these instructions may cause property damage, personal injury or even death.

2. Prepare the anti-sway bar for installation.  
Compare the factory bar and our bar side by side. Note the location of the anti-sway bar bushings. Lubricate the inside of the bushings with the provided grease.
3. Place the anti-sway bar in position.  
Install the lubed bushings onto bar and secure it using the provided clamps. Reuse the factory hardware, and torque to factory specs. Connect the factory endlinks to the ends of the bar and torque to factory specs.
4. Road test. Listen for noise.

## **WARNING**

After road testing, re-check all fasteners for proper tightness — if a fastener has worked loose or fallen off, re-tighten or replace it. Without all kit components properly tightened or in place, the anti-sway bar will not stabilize the vehicle at full capacity, which may cause reduced cornering ability or other reductions in vehicle handling or performance.

Failure to follow these instructions may result in property damage, personal injury or even death.

5. Re-inspect installation and retighten if necessary.

## **WARNING**

### **The anti-sway bar is not a load-bearing component**

Do not tow or hoist the vehicle using the anti-sway bar or its mounting brackets as attachment points. The anti-sway bar is not designed to carry the weight of the vehicle and may collapse, which will damage the anti-sway bar components, the suspension, or other components. The vehicle will detach or fall, which may cause severe personal injury.

Failure to follow these instructions may result in property damage, personal injury or even death.