

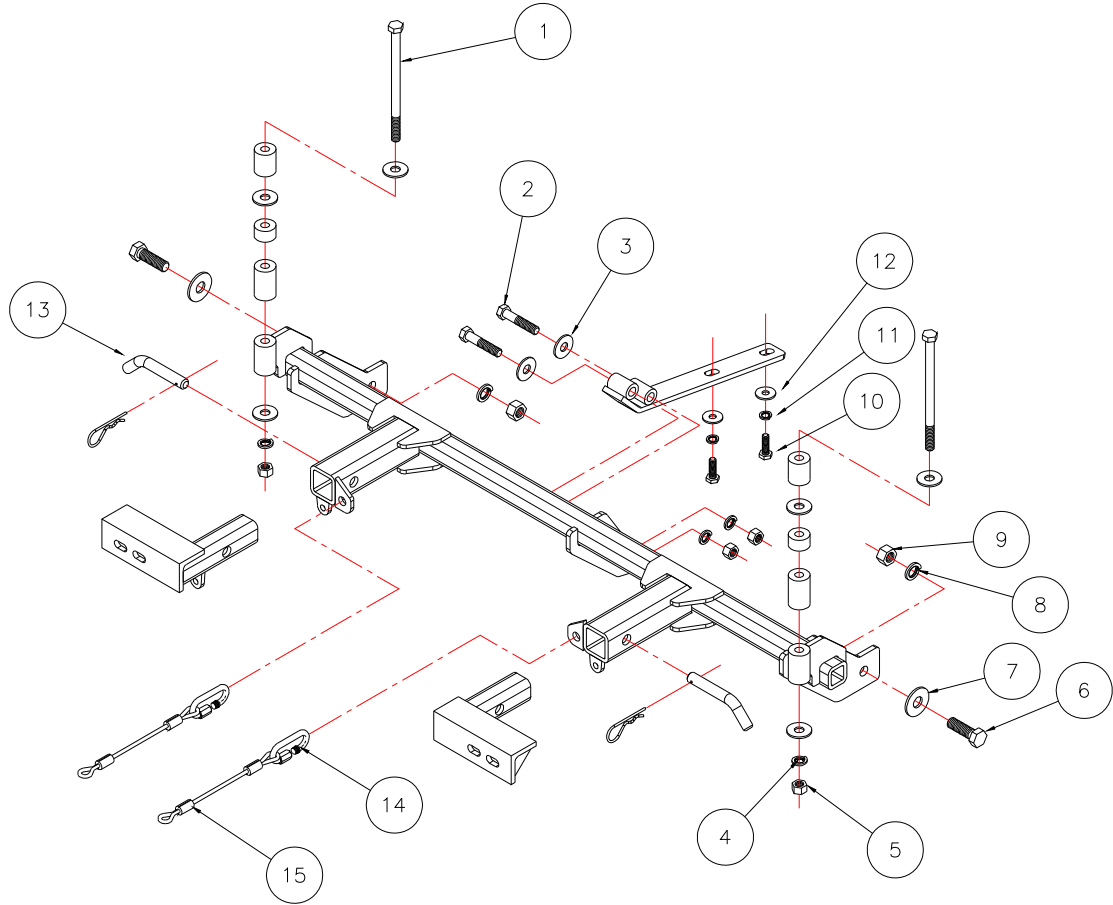

# BASEPLATE KIT INSTALLATION INSTRUCTIONS

**KIT# 1166-1**  
10/28/03

ROADMASTER, Inc. 6110 NE 127th Ave. Vancouver, WA 98682 1-800-669-9690 fax 360-735-9300 www.roadmasterinc.com



Item	Qty	Length	Width		Part No.
1	2	7 1/2"	1/2"	1/2" x 7 1/2" BOLT	350112-00
2	2	2 1/2"	1/2"	1/2" x 2 1/2" BOLT	350099-00
3	8		1/2"	1/2" FLAT WASHER	350308-00
4	4		1/2"	1/2" LOCK WASHER	350308-00
5	4		1/2"	1/2" NUT	350258-00
6	2	1 3/4"	5/8"	5/8" x 1 3/4" BOLT	350149-00
7	2		5/8"	5/8" FLAT WASHER	350312-00
8	2		5/8"	5/8" LOCK WASHER	350313-00
9	2		5/8"	5/8" NUT	350262-00
10	2	30mm	10mm	M10 x 1.25 x 30mm	356201-00
11	2		10mm	M10 LOCK WASHER	355715-00
12	2		10mm	M10 FENDER WASHER	355716-00
13	2			DRAWPIN/SPRINGPIN	357035-00
14	2			CABLE CONNECTOR	200008-00
15	2	8"		SAFETY CABLES	650646-08

ROADMASTER, INC.



# BASEPLATE KIT INSTALLATION INSTRUCTIONS

**KIT# 1166-1**  
10/28/03

ROADMASTER, Inc. 6110 NE 127th Ave. Vancouver, WA 98682 1-800-669-9690 fax 360-735-9300 www.roadmasterinc.com

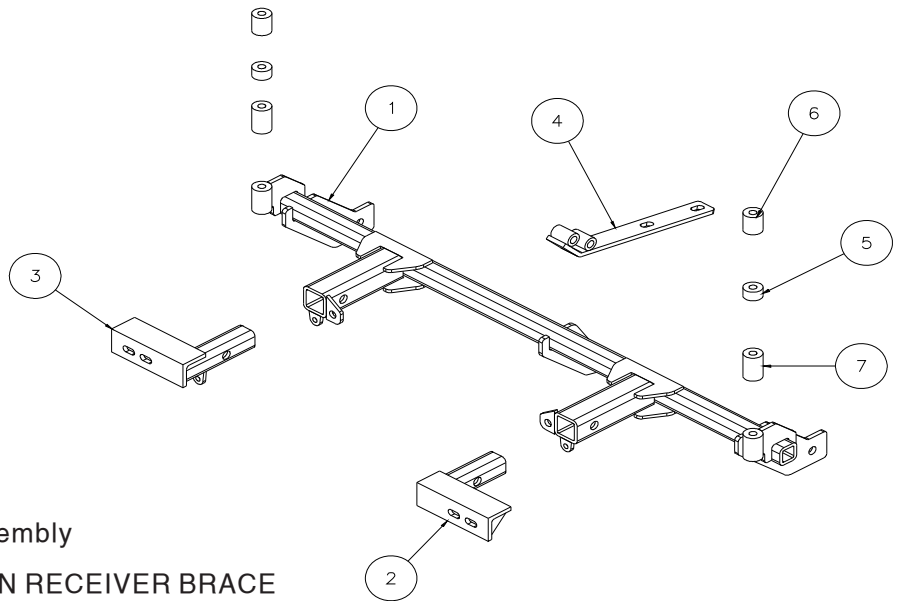

Item	Qty	Assy No.	Assembly
1	1	C-000491	MAIN RECEIVER BRACE
2	1	C-000492	DRIVER SIDE ARM WELDMENT
3	1	C-000493	PASSENGER SIDE ARM WELDMENT
4	1	C-000494	DEAD BRACE WELDMENT

**IMPORTANT:** All baseplates **must** be assembled with all the bolts left loose for final adjustment and positioning (before tightening) unless otherwise instructed. All bolts **must** be torqued for proper strength. If more than one bolt is used per fastening point, the diagram may only show one. Use flat washers over all slotted holes and lock washers on all fasteners.

## WARNING

Failure to heed these warnings or follow the installation instructions may result in a voided warranty, loss of towed vehicle, personal injury or death.

- Do not weld or modify this baseplate or its components. Welding or modification will void the warranty.
- Do not use this document as a basis to design/fabricate a baseplate, as it may not show all parts or structural components.
- We strongly recommend professional installation.
- If the towed vehicle has been in an accident, it must be properly repaired before attaching the baseplate. Do not install the baseplate if any structural frame damage is found.
- The installer must use all bolts and parts supplied. If running changes were made by the vehicle manufacturer after this kit was designed, some bolts or other fasteners may no longer be the correct size. It is the installer's responsibility to verify this kit is securely fastened to the vehicle.
- Use Loctite® Red on all bolts used to secure this baseplate. Torque all bolts to the specifications found at the end of these instructions. Do not over-torque the bolts or failure may occur.
- The installer must inspect the baseplate to ensure adequate clearance, particularly around hoses, air conditioner lines, radiators, etc. or non-warranty failure may result.
- Roadmaster manufactures many styles of baseplates. If your baseplate has removable arms, they must be removed before driving the vehicle, unless the arms can be pinned or padlocked in place. If not secured, the arms could vibrate out.
- Some motorhome chassis have such a tight turning radius that you can damage your motorhome, towed vehicle, tow bar or baseplate while turning sharply. Before getting on the road, test your turning radius in an empty parking lot. Turning too sharply could

result in non-warranty damage to your towing system, motorhome and/or towed vehicle.

- Do not back up with the towed vehicle attached or non-warranty damage will occur to your towing system or vehicles.
- The safety cables must connect the towing vehicle to the towed vehicle frame to frame, with the cables crossed, with enough slack for sharp turns. Failure to do so will result in non-warranty damage and/or the loss of the towed vehicle.
- This kit is designed for use with ROADMASTER tow bars and ROADMASTER adapters only. Using this kit with other brands, without an approved ROADMASTER adapter, may result in non-warranty damage or injury.
- Receiver extensions and out-of-level towing situations of 3 inches or more. This can cause the system to swing much higher and lower, causing excessive strain on the tow bar, baseplate and frame. That can cause the towing system to fail, causing property damage, personal injury or even death. If you must use a receiver extension or drop hitch to tow, it will reduce your receiver's weight capacity by 1/3 to avoid damaging your system. Never use more than one extension and/or drop hitch, as this will void your warranty.
- Every 3,000 miles, the owner must inspect all mounting points for cracks or fatigue, and check the fasteners for proper torque, according to the bolt torque requirements chart on the last page of these instructions.
- The owner must follow the vehicle manufacturer's instructions to prepare the vehicle for towing. Failure to do so may cause severe damage to the vehicle.
- This baseplate is only warranted for the original installation. Installing a used baseplate on another vehicle is not recommended and will void the warranty.



# BASEPLATE KIT INSTALLATION INSTRUCTIONS

KIT# 1166-1  
10/28/03

ROADMASTER, Inc. 6110 NE 127th Ave. Vancouver, WA 98682 1-800-669-9690 fax 360-735-9300 www.roadmasterinc.com

1. This bracket kit is one of our XL series, which is designed to be partly removable. The kit consists of the main receiver brace, front braces and a hardware pack. The main receiver brace mounts behind the front bumper fascia to the frame and side of the radiator support on each side (Fig.A). The front braces insert into the receivers on each side. Start by laying the kit out according to the illustration. **Important: please use all supplied bolts and parts and read all instructions carefully before beginning this installation. The majority of questions you may have can be answered within the text, and proper installation will ensure safe and secure travel.** Now, begin the installation.

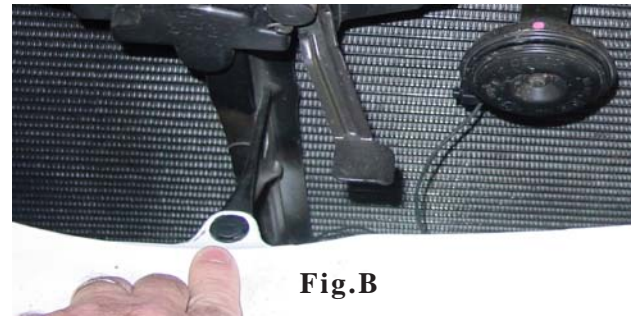
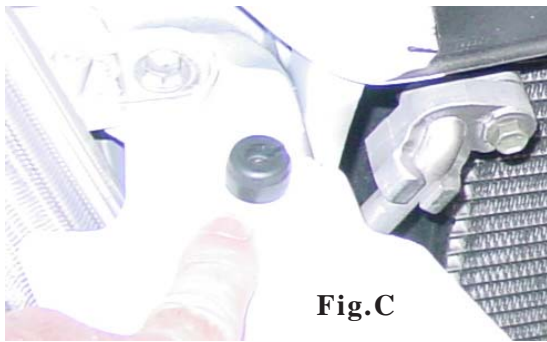

2. Start by removing the center plastic fasteners in the top of the fascia between the headlights (Fig.B) and a rubber bumper screw beside each headlight (Fig.C).

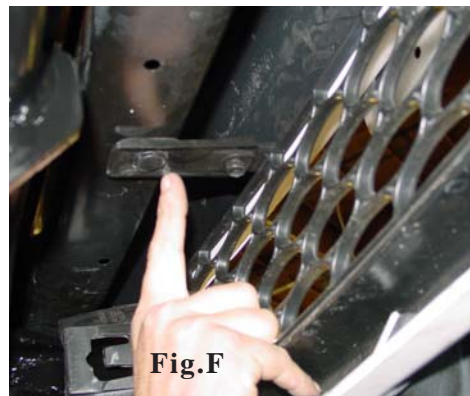

3. Remove two more bottom screws from the fender well liners on each side then pull back to gain access to the fascia fender fasteners (Fig.D).
4. Pull the fender liner back and disconnect the fog light if present on each side.

All illustrations and specifications contained herein are based on the latest information available at the time of publication approval. ROADMASTER, INC. reserves the right to make changes at any time without notice in material, specification and models or to discontinue models.



# BASEPLATE KIT INSTALLATION INSTRUCTIONS

**KIT# 1166-1**  
10/28/03

ROADMASTER, Inc. 6110 NE 127th Ave. Vancouver, WA 98682 1-800-669-9690 fax 360-735-9300 www.roadmasterinc.com

ROADMASTER, INC.

- 5. Remove the fender fascia junction screws on each side (Fig.E) and two plastic fasteners under the bumper core (Fig.F).
- 6. Pull the fascia forward to remove and set aside. Also remove the Styrofoam energy absorber on the front of the bumper core (Fig.G).



- 7. Hold the main receiver brace below the bumper core with the side over the tie down plate mounting holes. Bolt in place with two 5/8" x 1 3/4" bolts through the tie down plates on each side.
- 8. Bolt through existing holes in the end of the bumper core with 1/2" x 7 1/2" bolts, 1 1/2", 3/4", 2" spacers, lock washers and nuts. The spacers go in the bumper core as shown then the bolt goes through the assembly and the end mounts on the receiver brace (Fig.H).

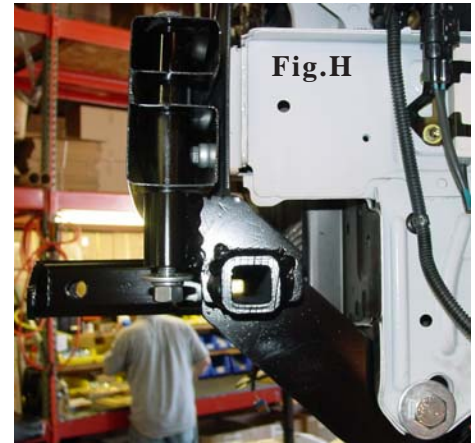

- 9. Remove two bolts from the bottom of the motor mount and bolt through the lower center brace with two 10mm x 1.25 x 30mm bolts (Fig.I), then bolt the lower brace to the receiver brace with two 1/2" x 2 1/2" bolts, lock washers and nuts.

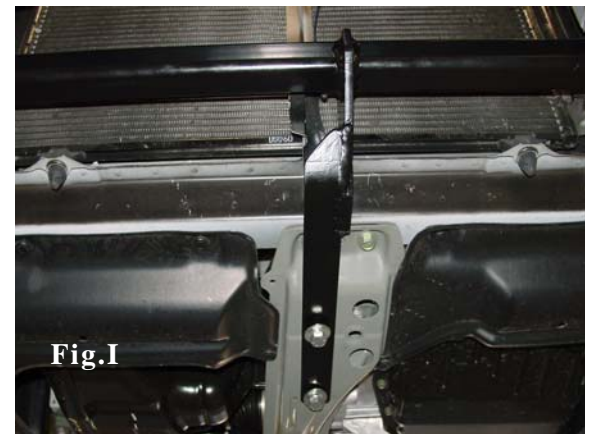

- 10. Align the receiver brace and tighten all mounting bolt to the torque specifications below.
- 11. Trial fit the fascia and mark the area on the grille beside the fog light openings where the receiver tubes on the main brace touch. Trim this area so that the fascia can be mounted.
- 12. Refit the fascia and the energy foam reversing steps two through six.
- 13. Torque all mounting bolts to the torque specifications below.
- 14. Install the front braces in the receiver tubes and pin from the top with 5/8" draw pins and spring pins.
- 15. Install the safety cables and connectors as shown.

### BOLT TORQUE REQUIREMENTS

Note: The torque values represented below are intended as general guidelines. Torque requirements for specific applications may vary. Roadmaster does not warrant this information to be accurate for all applications and disclaims all liability for any claims or damages which may result from its use.

STANDARD BOLTS			METRIC BOLTS			METRIC BOLTS		
Thread Size	Grade	Torque	Thread Size	Grade	Plated/Unplated	Thread Size	Grade	Plated/Unplated
5/16	5	13 ft./lb.	8mm-1.0	8.8	20 ft./lb. 18 ft./lb.	12mm-1.25	8.8	70 ft./lb. 65 ft./lb.
3/8	5	23 ft./lb.	8mm-1.25	8.8	19 ft./lb. 18 ft./lb.	12mm-1.5	8.8	66 ft./lb. 61 ft./lb.
7/16	5	37 ft./lb.	10mm-1.25	8.8	38 ft./lb. 36 ft./lb.	12mm-1.75	8.8	65 ft./lb. 60 ft./lb.
1/2	5	56 ft./lb.	10mm-1.5	8.8	37 ft./lb. 35 ft./lb.	14mm-2.0	8.8	104 ft./lb. 97 ft./lb.
5/8	5	150 ft./lb.						

All illustrations and specifications contained herein are based on the latest information available at the time of publication approval. ROADMASTER, INC. reserves the right to make changes at any time without notice in material, specification and models or to discontinue models.