



# BASEPLATE KIT INSTALLATION INSTRUCTIONS

**KIT# 1177-3**

04/18/05  
RV

ROADMASTER, Inc. 6110 NE 127th Ave. Vancouver, WA 98682 360-896-0407 fax 360-735-9300 www.roadmasterinc.com

**Important**  
Note: this bracket will not accommodate the Guardian rock shield, some models of the Tow Defender, Stowaway or the StowMaster and StowMaster All Terrain tow bars.

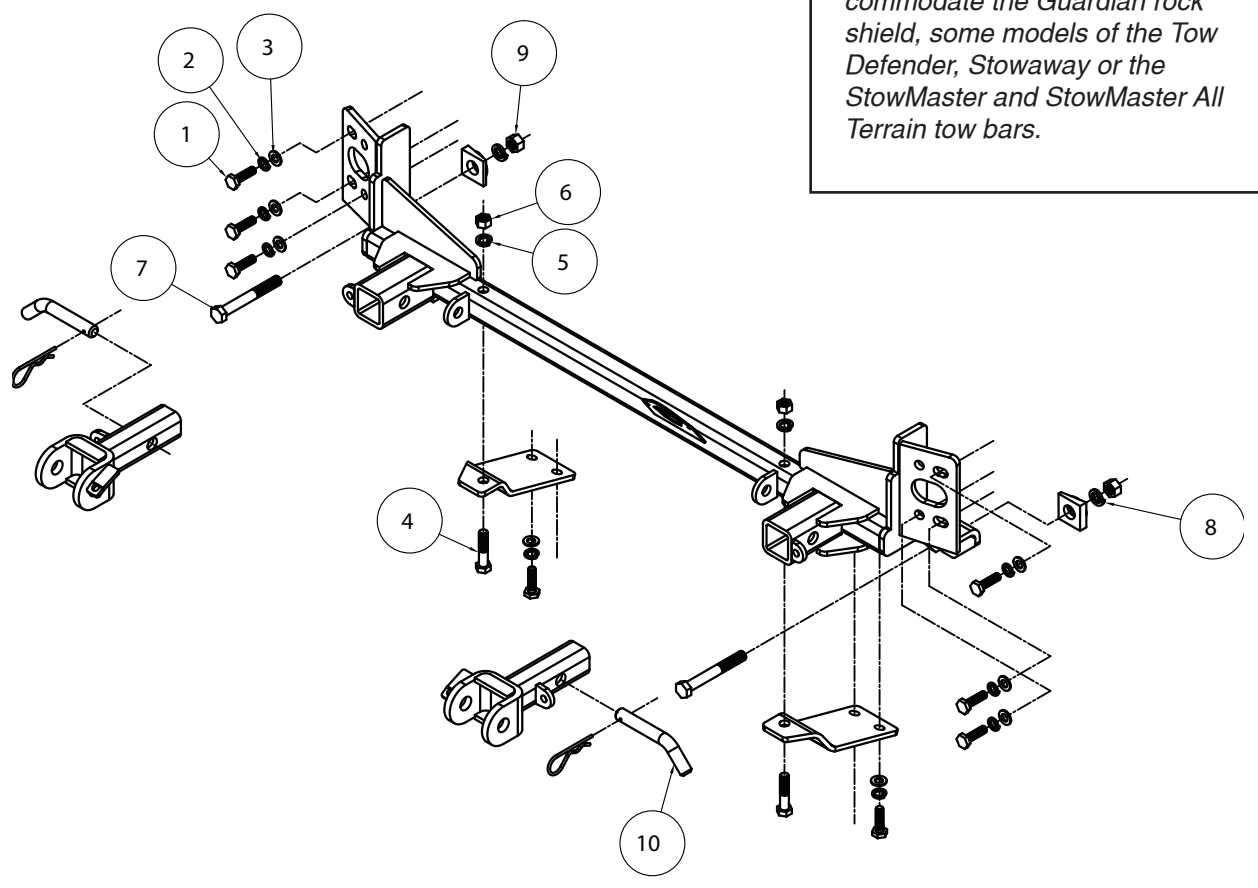

Item	Qty.	Length	Width	Description	Part #
1.....	8	35mm	10mm	10mm X 1.25 X 35mm	356202-00
2.....	8		10mm	LOCK WASHER	355715-00
3.....	8		10mm	FLAT WASHER	355710-00
4.....	2	2 1/2"	7/16"	BOLT	350078-00
5.....	2		7/16"	LOCK WASHER	350307-00
6.....	2		7/16"	NUT	350256-00
7.....	2	4"	1/2"	BOLT	350124-00
8.....	2		1/2"	LOCK WASHER	350309-00
9.....	2		1/2"	NUT	350258-00
10.....	2			DRAW PIN/SPRING PIN	357035-00



# BASEPLATE KIT INSTALLATION INSTRUCTIONS

**KIT# 1177-3**

04/18/05  
RV

ROADMASTER, Inc. 6110 NE 127th Ave. Vancouver, WA 98682 360-896-0407 fax 360-735-9300 www.roadmasterinc.com

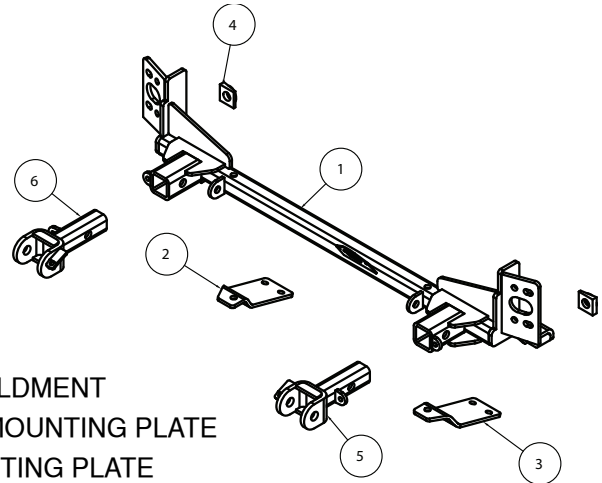

Item	Qty.	Part #	Description
1.....	1 .....	C-001232 .....	MAIN RECEIVER BRACE WELDMENT
2.....	1 .....	B-000839 .....	PASSENGER SIDE LOWER MOUNTING PLATE
3.....	1 .....	B-000838 .....	DRIVER SIDE LOWER MOUNTING PLATE
4.....	2 .....	C-001236 .....	BEVELED WASHER WELDMENT
5.....	1 .....	C-001237 .....	DRIVER SIDE ARM BRACE WELDMENT
6.....	1 .....	C-001238 .....	PASSENGER SIDE ARM BRACE WELDMENT

**IMPORTANT:** All baseplates *must* be assembled with all the bolts left loose for final adjustment and positioning (before tightening) unless otherwise instructed. All bolts *must* be torqued for proper strength. If more than one bolt is used per fastening point, the diagram may only show one. Use flat washers over all slotted holes and lock washers on all fasteners.

## WARNING

Failure to heed these warnings or follow the installation instructions may result in a voided warranty, loss of towed vehicle, personal injury or death.

- Do not weld or modify this baseplate or its components. Welding or modification will void the warranty.
- Do not use this document as a basis to design/fabricate a baseplate, as it may not show all parts or structural components.
- We strongly recommend professional installation.
- If the towed vehicle has been in an accident, it must be properly repaired before attaching the baseplate. Do not install the baseplate if any structural frame damage is found.
- The installer must use all bolts and parts supplied. If running changes were made by the vehicle manufacturer after this kit was designed, some bolts or other fasteners may no longer be the correct size. It is the installer's responsibility to verify this kit is securely fastened to the vehicle.
- Use Loctite® Red on all bolts used to secure this baseplate. Torque all bolts to the specifications found at the end of these instructions. Do not over-torque the bolts or failure may occur.
- The installer must inspect the baseplate to ensure adequate clearance, particularly around hoses, air conditioner lines, radiators, etc. or non-warranty failure may result.
- Roadmaster manufactures many styles of baseplates. If your baseplate has removable arms, they must be removed before driving the vehicle, unless the arms can be pinned or padlocked in place. If not secured, the arms could vibrate out.
- Some motorhome chassis have such a tight turning radius that you can damage your motorhome, towed vehicle, tow bar or baseplate while turning sharply. Before getting on the road, test your turning radius in an empty parking lot. Turning too sharply could

result in non-warranty damage to your towing system, motorhome and/or towed vehicle.

- Do not back up with the towed vehicle attached or non-warranty damage will occur to your towing system or vehicles.
- The safety cables must connect the towing vehicle to the towed vehicle frame to frame, with the cables crossed, with enough slack for sharp turns. See cable instructions for proper routing. Failure to do so will result in non-warranty damage and/or the loss of the towed vehicle.
- This kit is designed for use with ROADMASTER tow bars and ROADMASTER adapters only. Using this kit with other brands, without an approved ROADMASTER adapter, may result in non-warranty damage or injury.
- Receiver extensions and out-of-level towing situations of 3 inches or more. This can cause the system to swing much higher and lower, causing excessive strain on the tow bar, baseplate and frame. That can cause the towing system to fail, causing property damage, personal injury or even death. If you must use a receiver extension or drop hitch to tow, it will reduce your receiver's weight capacity by 1/3 to avoid damaging your system. Never use more than one extension and/or drop hitch, as this will void your warranty.
- Every 3,000 miles, the owner must inspect all mounting points for cracks or fatigue, and check the fasteners for proper torque, according to the bolt torque requirements chart on the last page of these instructions.
- The owner must follow the vehicle manufacturer's instructions to prepare the vehicle for towing. Failure to do so may cause severe damage to the vehicle.
- This baseplate is only warranted for the original installation. Installing a used baseplate on another vehicle is not recommended and will void the warranty.



# BASEPLATE KIT INSTALLATION INSTRUCTIONS

**KIT# 1177-3**

04/18/05  
RV

ROADMASTER, Inc. 6110 NE 127th Ave. Vancouver, WA 98682 360-896-0407 fax 360-735-9300 www.roadmasterinc.com

This is one of our MX series brackets, which allows the visible front portion of the brackets to be easily removed from the front of the vehicle (Fig.A and Fig.B). The bracket consists of a main receiver bracket, a cross brace, two lower support braces, two removable front braces and a hardware pack.

The main receiver brace mounts to the frame rails, the cross brace is also attached to the frame rails, and the lower support braces are attached to the core support. The removable front braces install in the main receiver brace.

Before starting the installation, lay out the kit components in order, as they will be used. This will give you a visual idea of how the components work, and will also confirm that everything is present and accounted for.

**1. Important: please use all supplied bolts and parts and read all instructions carefully before beginning this installation. The majority of questions you may have can be answered within the text, and proper installation will ensure safe and secure travel.** Now, begin the installation by removing three plastic fasteners, along the top edge of the fascia (Fig.C)

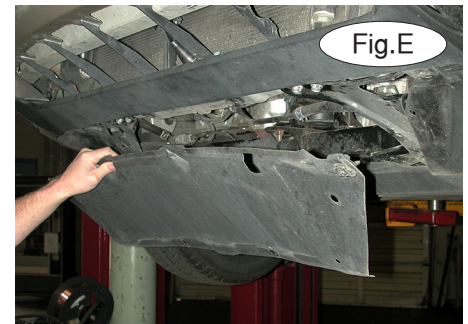
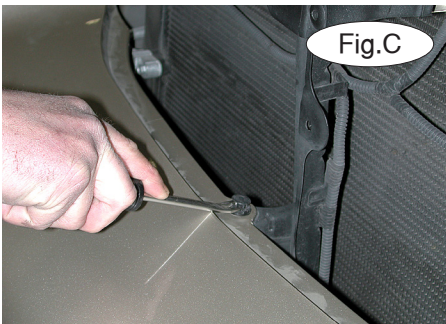

**2.** Next, remove ten 10mm (head) bolts and two plastic fasteners attaching the splash shield and the fascia to the subframe and the core support (Fig.D). Then, remove the splash shield (Fig.E).

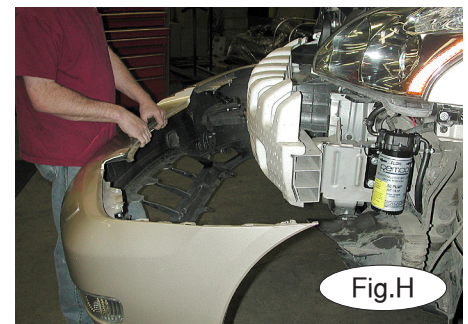

**3.** On each side, pull back the fender liner to expose a 10mm (head) bolt attaching the fascia to the fender. Remove the bolt (Fig.F).

**4.** On each side, pull out and forward to detach the fascia from the track. Disconnect the fog lights and the headlight washers, if the vehicle is so equipped. Then, pull out and away to remove the fascia (Fig.H).



# BASEPLATE KIT INSTALLATION INSTRUCTIONS

**KIT# 1177-3**

04/18/05  
RV

ROADMASTER, Inc. 6110 NE 127th Ave. Vancouver, WA 98682 360-896-0407 fax 360-735-9300 www.roadmasterinc.com

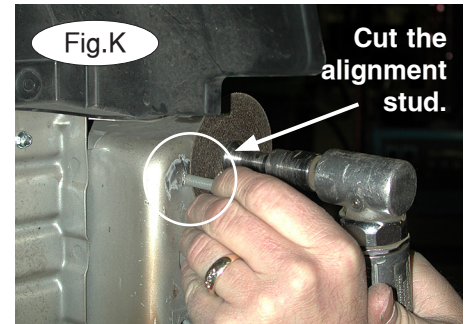
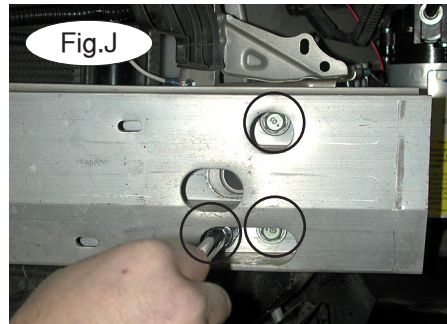
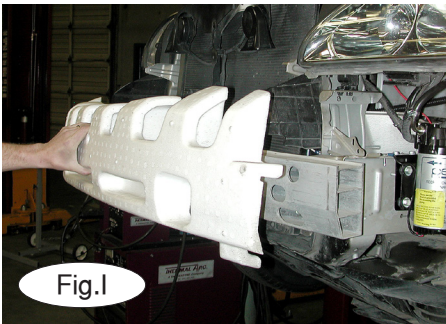

5. Remove the shock absorption pad (Fig.I). *Note:* it will not be replaced. Retain the shock absorption pad in case the bracket is ever removed.

6. Next, remove the bumper core – on each side, remove three 14mm (head) bolts attaching the bumper core to the ends of the frame rails (Fig.J). The bumper core will be replaced by the main receiver brace. Retain all parts and attachment hardware in case the bracket is ever removed.

7. Before mounting the main receiver brace, cut off an alignment stud on each side (Fig.K), so that the end of each frame rail is smooth.

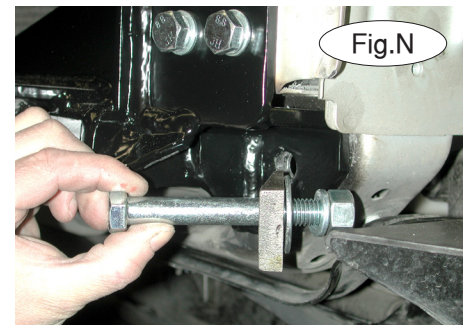
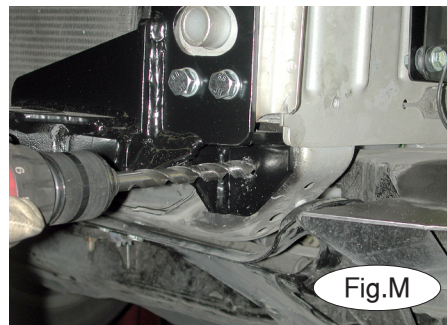

8. Position the main receiver bracket over the ends of both frame rails, so that the pre-drilled holes at each end of the bracket align to the holes for the bolts you removed in step 6. On each side, thread three 10mm x 1.25 x 35mm bolts, with a 10mm lock washer and flat washer, into the three holes (Fig.L). Torque the bolts to the specifications at the bottom of these instructions.

9. Using the hole in the bracket as a template, drill a 1/2" hole on each side, through both the front and the back sides of the frame rail (Fig.M). *Note:* be careful to avoid any lines or hoses in the engine compartment.

10. Fit a 1/2" x 4" bolt through the front of the frame rail, through one of the holes you drilled in the preceding step. Then, thread a 3/4" beveled washer, a lock washer and a nut onto the bolt.

Figure N shows the washers arranged in proper sequence, before installation. Repeat for the other side. *Note:* the beveled washer and the lock washer both mount to the back of the frame rail. Figure O shows the correct attachment. Torque the two bolts to the specifications at the bottom of these instructions.

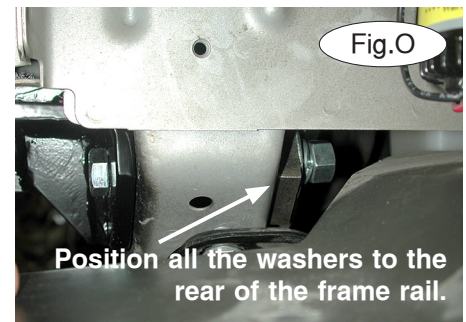



# BASEPLATE KIT INSTALLATION INSTRUCTIONS

**KIT# 1177-3**

04/18/05  
RV

ROADMASTER, Inc. 6110 NE 127th Ave. Vancouver, WA 98682 360-896-0407 fax 360-735-9300 www.roadmasterinc.com

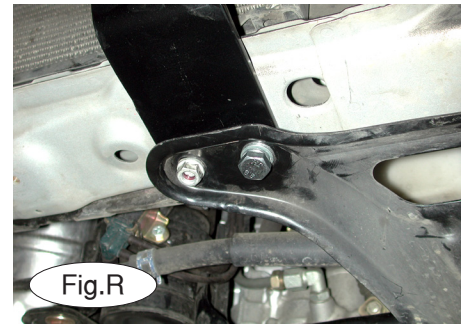
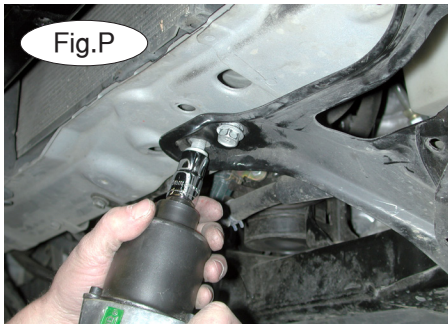

11. Now, attach the lower support braces. First, on each side, remove one 14mm (head) bolt and one 14mm (head) nut attaching the core support brace to the core support (Fig.P). Then loosen a 14mm bolt at the outside of each of the core support braces (Fig.Q).

12. Slide one of the lower support braces between the core support and the core support brace, so that the pre-drilled holes in the lower support brace align to the holes for the bolt and nut you removed in the preceding step. Replace the bolt with one of the supplied 10mm x 1.25 x 35mm bolts, flat washer and lock washer. Apply thread lock to the 14mm factory nut you removed in the preceding step, and replace it. Figure R shows the bolt and nut in place. Torque the bolt and nut to the specifications at the bottom of these instructions; repeat for the other side.

13. Attach each lower support brace to the main receiver brace with a 7/16" x 2½" bolt, lock washer and nut (Fig.S).

14. Reattach the splash shield and the fascia by reversing steps 1 through 4. Before fastening the fascia, it may be necessary to trim a small amount of the grille, in order to accommodate the main receiver brace.

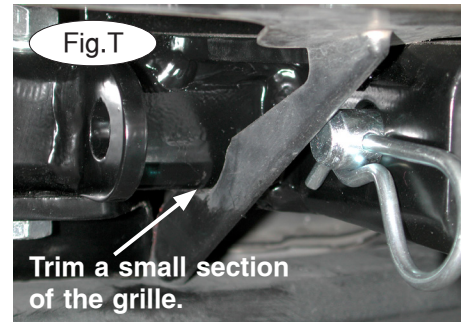
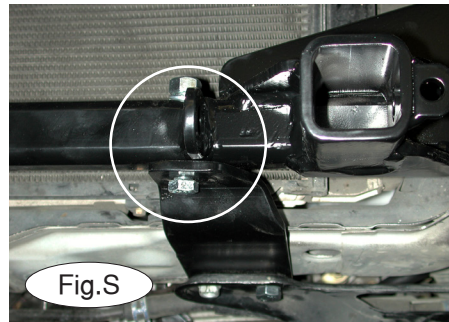

Test-fit the fascia to see if this is the case. If so, use Figure T as a reference.



# BASEPLATE KIT INSTALLATION INSTRUCTIONS

**KIT# 1177-3**

04/18/05  
RV

ROADMASTER, Inc. 6110 NE 127th Ave. Vancouver, WA 98682 360-896-0407 fax 360-735-9300 www.roadmasterinc.com

- 15. Ensure that all bolts are torqued to the specifications below.
- 16. Fit the front bracket arms into the front receiver braces, and secure them in place with the supplied 5/8" draw pins and spring pins (Fig.Q).
- 17. Install the tow bar to the mounting bracket according to the manufacturer's instructions. Attach the safety cables to the main receiver brace.



## BOLT TORQUE REQUIREMENTS

Note: The torque values represented below are intended as general guidelines. Torque requirements for specific applications may vary. Roadmaster does not warrant this information to be accurate for all applications and disclaims all liability for any claims or damages which may result from its use.

### STANDARD BOLTS

Thread Size	Grade	Torque
5/16.....	5.....	13 ft./lb.
3/8.....	5.....	23 ft./lb.
7/16.....	5.....	37 ft./lb.
1/2.....	5.....	56 ft./lb.
5/8.....	5.....	150 ft./lb.

### METRIC BOLTS

Thread Size	Grade	Plated / Unplated
8mm-1.0.....	8.8.....	20 ft./lb. 18 ft./lb.
8mm-1.25.....	8.8.....	19 ft./lb. 18 ft./lb.
10mm-1.25.....	8.8.....	38 ft./lb. 36 ft./lb.
10mm-1.5.....	8.8.....	37 ft./lb. 35 ft./lb.

### METRIC BOLTS

Thread Size	Grade	Plated / Unplated
12mm-1.25.....	8.8.....	70 ft./lb. 65 ft./lb.
12mm-1.5.....	8.8.....	66 ft./lb. 61 ft./lb.
12mm-1.75.....	8.8.....	65 ft./lb. 60 ft./lb.
14mm-2.0.....	8.8.....	104 ft./lb. 97 ft./lb.

All illustrations and specifications contained herein are based on the latest information available at the time of publication approval. ROADMASTER, INC. reserves the right to make changes at any time without notice in material, specification and models or to discontinue models.