



Installation Instructions

Thank you for purchasing this anti-sway bar kit. Please read through these instructions before installation.

Front Anti-Sway Bar Kit Workhorse W16/18 Chassis

part #1259-115
1-5/8" diameter

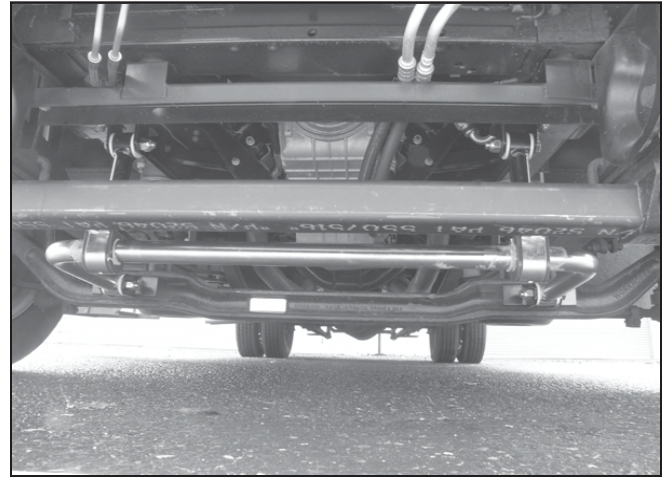

INTRODUCTION

Thank you for purchasing this anti-sway bar kit. This kit is designed to improve the handling characteristics of your Workhorse by reducing the body roll and balancing the weight transfer during cornering. The anti-sway bar kit is engineered for long life and trouble-free performance. For maximum suspension control, use this kit along with our rear anti-sway bar kit.

All the hardware needed for installation is included in this kit. Refer to the PARTS LIST in these instructions to identify the parts.

SUGGESTED TOOLS

The following tools are suggested to complete the installation procedures:

- General hand tools
- 1/8", 1/2" drill bits
- 1/2" drill
- Torque wrench

WARNING

- If raising the vehicle to install the anti-sway bar, always support the vehicle with jack stands at both frame rails or at the rear axle before working underneath. Ensure that the jack stands are securely positioned, and are rated at or above the weight of the vehicle.
- The installer must read the instructions and use all bolts and parts supplied. Use only the parts supplied by ROADMASTER to install this kit.
- Minor modifications are sometimes necessary due to slight vehicle variations, even for the same year, make and model.
- If running changes were made by the manufacturer after this kit was designed, there may be weldments, braces, gussets, or other structural items which interfere with the installation. It is the installer's responsibility to allow for these running changes without sacrificing the structural integrity of the anti-sway bar. Failure to securely fasten the anti-sway bar could result in property damage, personal injury or even death.
- ROADMASTER will not be responsible for any damage or injury resulting from any modification or alteration.
- Check ALL the fasteners for tightness before and after road testing the vehicle.
- Do not use this document for custom fabrication, as it may not show all parts or structural components.
- Do not use an air impact wrench when re-installing bolts, as stripped threads may result.
- This anti-sway bar is only warranted for the original installation. Installing a used anti-sway bar on another vehicle is not recommended and will void the warranty.

WARNING

Failure to follow these instructions can result in property damage, personal injury or even death.

INSTALLATION

The following instructions must be followed in the order listed to ensure a proper installation and to preserve the ROADMASTER warranty.

1. Install the axle brackets.

Remove the two front U-bolt nuts on each side. Install B537 axle brackets and reinstall the nuts. Do not tighten at this time (Figure 1).

2. Install the driver's side frame bracket.

Locate the rear steering box bracket on the outside of the frame rail. The driver's side bracket (B547) will mount just behind the steering box bracket, toward the rear (Figure 2). Clamp the bracket into place and use the holes in the bracket as a template, mark the holes on the outside of the frame rail. Remove the bracket and drill two 1/2" holes through the frame (make sure to protect any lines or wires that may be inside the frame). Install the bracket using 1/2 x 1 1/2" bolts (350097-00) and secure with the washers and nuts. Torque to 80-100ft.-lbs.. Assemble the spacer plate and clamp plate as shown using 7/16" bolts, washers and nuts. Tighten the clamp bolts to 40-50ft.-lbs. (Figure 3).

3. Install the passenger side frame bracket.

The passenger side frame bracket is located directly opposite of the driver's side. Clamp in place, mark the holes and repeat step 2 for the passenger side.

4. Mount the bar.

Attach the anti-sway bar to axle plates using 5/8" bolts (350163-00). Tighten to 30-45 ft.-lbs.(Figure 4).

5. Assemble and connect the drop links.

Install the bushings (205209-00) and sleeves (205503-00) into drop links. Attach to frame brackets on each side. Tighten to 30-45 ft.-l lbs.(Figure 5).

6. Connect the anti-sway bar to the drop links.

Lubricate the inside of the anti-sway bar bushings with the provided grease (Figure 6)). Install the anti-sway bar bushings and U-clamps on the bar. Connect the anti-sway bar to drop links using bolts (350096-80) provided. Torque to 60-75 ft.-lbs.(Figure 5).

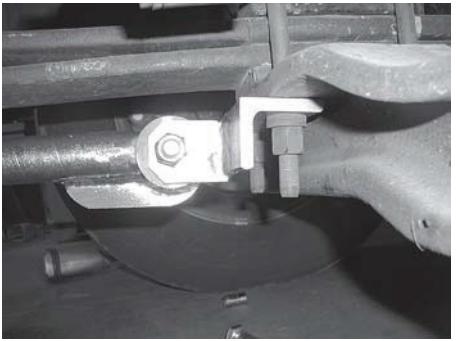

Figure 1

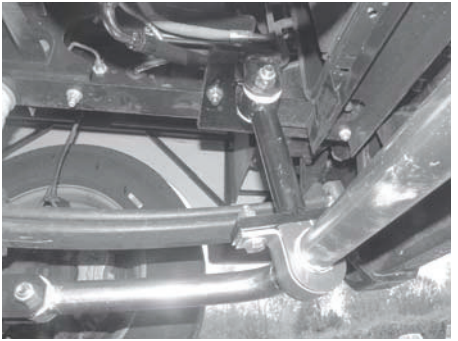

Figure 2

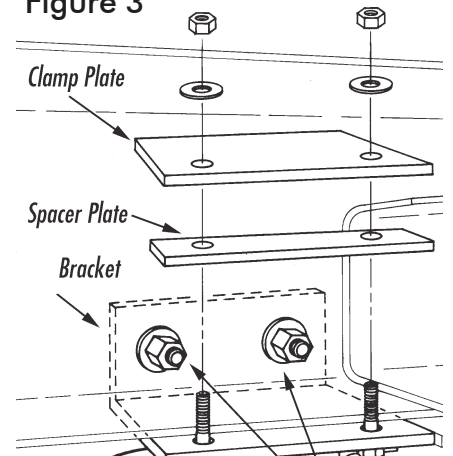

Figure 4

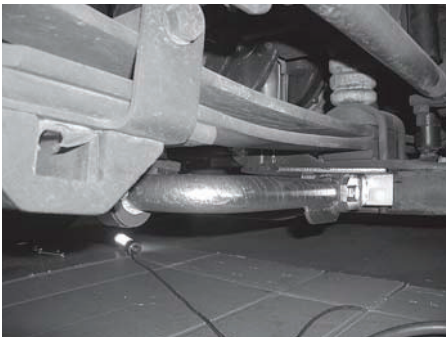

Figure 5

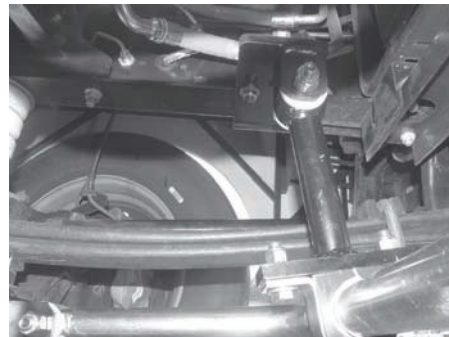
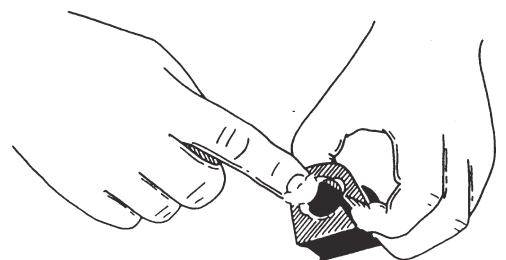

Figure 6



INSTALLATION

7. Tighten the remaining fasteners.

Tighten the axle clamps to factory specs.

8. Road test.

Test drive, listen for any unusual noises. Re-inspect installation.



WARNING

After road testing, re-check all fasteners for proper tightness — if a fastener has worked loose or fallen off, re-tighten or replace it. Without all kit components properly tightened or in place, the anti-sway bar will not stabilize the vehicle at full capacity, which may cause reduced cornering ability or other reductions in vehicle handling or performance.

Failure to follow these instructions may result in property damage, personal injury or even death.



WARNING

The anti-sway bar is not a load-bearing component

Do not tow or hoist the vehicle using the anti-sway bar or its mounting brackets as attachment points. The anti-sway bar is not designed to carry the weight of the vehicle and may collapse, which will damage the anti-sway bar components, the suspension, or other components. The vehicle will detach or fall, which may cause severe personal injury.

Failure to follow these instructions may result in property damage, personal injury or even death.