



# BASEPLATE KIT INSTALLATION INSTRUCTIONS

**KIT# 1544-1**

02/25  
RS

ROADMASTER, Inc.

6110 NE 127th Ave.

Vancouver, WA 98682

360-896-0407

www.RoadmasterInc.com

Need Help? Call Toll-Free

1-800-669-9690

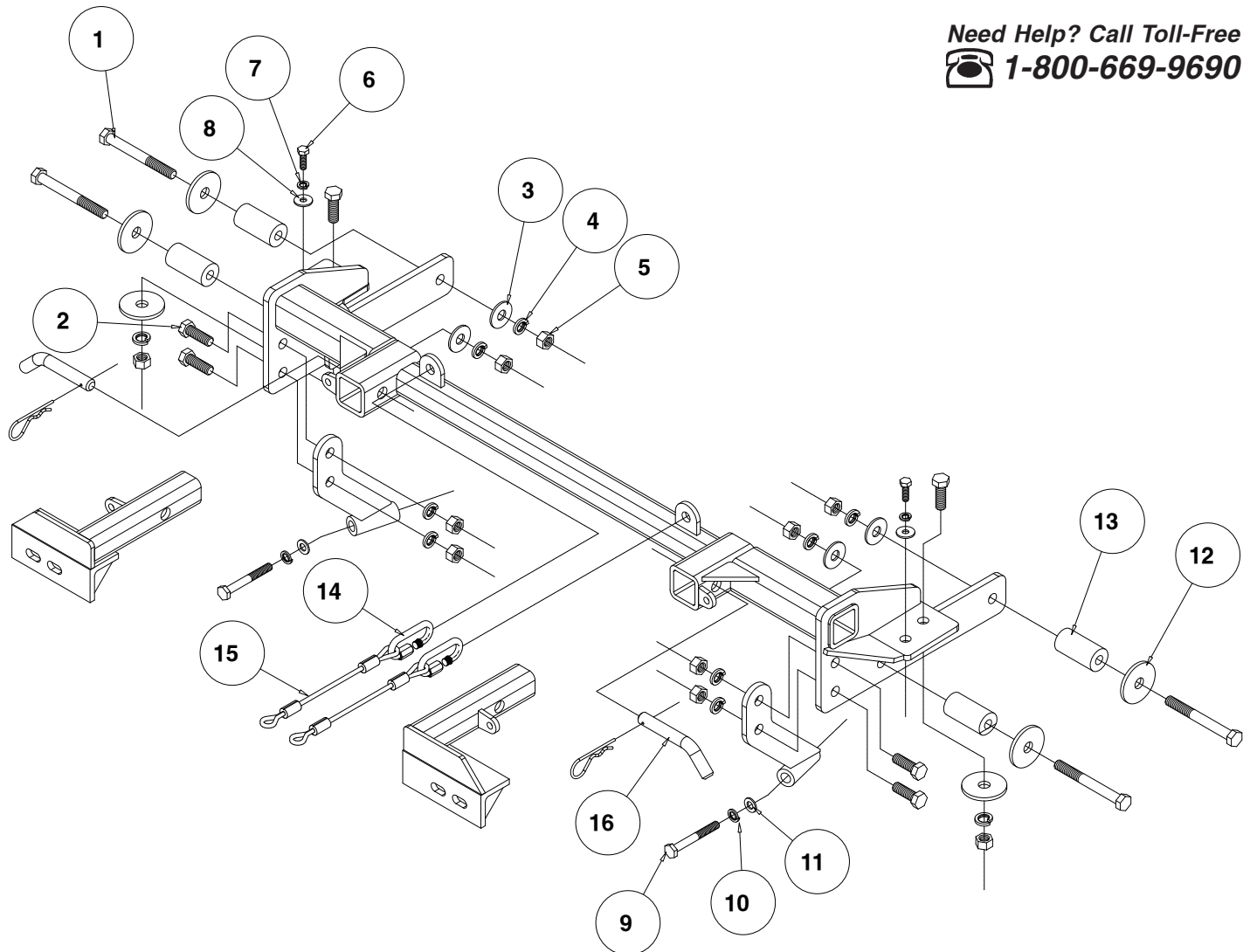

Item....	Qty....	Length	Width	Description .....	Part#
1.....	4	4 1/2"	1/2"	BOLT .....	350106-00
2.....	6	1 1/2"	1/2"	BOLT .....	350095-00
3.....	6		1/2"	FLAT WASHER .....	350308-00
4.....	10		1/2"	LOCK WASHER .....	350309-00
5.....	10		1/2"	NUT .....	350258-00
6.....	2	25MM..	8MM	M8 x 1.25 x 25MM BOLT .....	356008-00
7.....	2		8MM	LOCK WASHER .....	355705-00
8.....	2		8MM	FENDER WASHER .....	355702-00
9.....	2	80MM..	10MM	M10 x 1.25 x 80MM BOLT .....	356214-00
10.....	2		10MM	LOCK WASHER .....	355715-00
11.....	2		10MM	FENDER WASHER .....	355716-00
12.....	4		1/2"	PLATE WASHER .....	350351-00
13.....	2			CONNECTOR .....	200008-00
14.....	2	10"		10" SAFETY CABLES .....	500646-10
15.....	2			DRAW PIN / SPRING PIN .....	357035-00
16.....	2			ZIP TIES BLACK .....	300140-10
17.....	1			MAIN BRACE WELDMENT .....	C-000433
18.....	1			PASSENGER SIDE ARM WELDMENT .....	C-000434
19.....	1			DRIVER SIDE ARM WELDMENT .....	C-000435
20.....	1			DRIVER SIDE LOWER BRACE WELDMENT .....	C-000436
21.....	1			PASSENGER SIDE LOWER BRACE WELDMENT .....	C-000437
22.....	2			2 3/8" TUBE SPACER .....	A-004269
23.....	2			2 3/8" TUBE SPACER WITH BEVEL .....	A-000799



# BASEPLATE KIT INSTALLATION INSTRUCTIONS

**KIT# 1544-1**

02/25  
RS

ROADMASTER, Inc.

6110 NE 127th Ave.

Vancouver, WA 98682

360-896-0407

www.RoadmasterInc.com

This bracket kit is one of our XL series, which allows the visible front portion of the brackets to be easily removed from the front of the vehicle (Fig.A and B). The kit consists of the main receiver brace, two front arm braces, two lower braces and a hardware pack. The main receiver brace mounts behind the front bumper fascia to the inside of the frame. The lower braces attach to the front of the radiator support on each side. The front arm braces insert into the receivers on each side.

Before starting the installation, lay out the kit components in order, starting with step 1. This will give you a visual idea of how the kit installs, and will also confirm that all the components are present and accounted for.



**IMPORTANT:** All baseplates **must** be assembled with all the bolts left loose for final adjustment and positioning (before tightening) unless otherwise instructed. All bolts **must** be torqued for proper strength. If more than one bolt is used per fastening point, the diagram may only show one. Use flat washers over all slotted holes and lock washers on all fasteners.

## WARNING

Failure to heed these warnings or follow the installation instructions may result in a voided warranty, loss of towed vehicle, personal injury or death.

- Do not weld or modify this baseplate or its components. Welding or modification will void the warranty.
- Do not use this document as a basis to design/fabricate a baseplate, as it may not show all parts or structural components.
- We strongly recommend professional installation.
- If the towed vehicle has been in an accident, it must be properly repaired before attaching the baseplate. Do not install the baseplate if any structural frame damage is found.
- The installer must use all bolts and parts supplied. If running changes were made by the vehicle manufacturer after this kit was designed, some bolts or other fasteners may no longer be the correct size. It is the installer's responsibility to verify this kit is securely fastened to the vehicle.
- Use Loctite® Red on all bolts used to secure this baseplate. Torque all bolts to the specifications found at the end of these instructions. Do not over-torque the bolts or failure may occur.
- The installer must inspect the baseplate to ensure adequate clearance, particularly around hoses, air conditioner lines, radiators, etc. or non-warranty failure may result.
- Roadmaster manufactures many styles of baseplates. If your baseplate has removable arms, they must be removed before driving the vehicle, unless the arms can be pinned or padlocked in place. If not secured, the arms could vibrate out.
- Some motorhome chassis have such a tight turning radius that you can damage your motorhome, towed vehicle, tow bar or baseplate while turning sharply. Before getting on the road, test your turning radius in an empty parking lot. Turning too sharply could result in non-warranty damage to your towing system, motorhome and/or towed vehicle.
- Do not back up with the towed vehicle attached or non-warranty damage will occur to your towing system or vehicles.
- The safety cables must connect the towing vehicle to the towed vehicle frame to frame, with the cables crossed, with enough slack for sharp turns. See cable instructions for proper routing. Failure to do so will result in non-warranty damage and/or the loss of the towed vehicle.
- This kit is designed for use with ROADMASTER tow bars and ROADMASTER adapters only. Using this kit with other brands, without an approved ROADMASTER adapter, may result in non-warranty damage or injury.
- Receiver extensions and out-of-level towing situations of 3 inches or more. This can cause the system to swing much higher and lower, causing excessive strain on the tow bar, baseplate and frame. That can cause the towing system to fail, causing property damage, personal injury or even death. If you must use a receiver extension or drop hitch to tow, it will reduce your receiver's weight capacity by 1/3 to avoid damaging your system. Never use more than one extension and/or drop hitch, as this will void your warranty.
- Every 3,000 miles, the owner must inspect all mounting points for cracks or fatigue, and check the fasteners for proper torque, according to the bolt torque requirements chart on the last page of these instructions.
- The owner must follow the vehicle manufacturer's instructions to prepare the vehicle for towing. Failure to do so may cause severe damage to the vehicle.
- This baseplate is only warranted for the original installation. Installing a used baseplate on another vehicle is not recommended and will void the warranty.



# BASEPLATE KIT INSTALLATION INSTRUCTIONS

**KIT# 1544-1**

02/25  
RS

ROADMASTER, Inc.

6110 NE 127th Ave.

Vancouver, WA 98682

360-896-0407

www.RoadmasterInc.com



Fig.C



Fig.D



Fig.E

1. **Important:** please use all supplied bolts and parts and read all instructions carefully before beginning this installation. The majority of questions you may have can be answered within the text, and proper installation will ensure safe and secure travel. Now, begin the installation by removing the plastic fasteners in the top of the front bumper fascia holding the radiator cover (Fig.C). These consist of 13 plastic fasteners for the Honda Pilot, or 15 for the Acura MDX. Set the cover aside.

2. Remove three fasteners from the front of each fender well, then two 10mm head bolts and two plastic fasteners under the bumper fascia on each side. Disconnect the fog lights, if the vehicle is so equipped, and pull forward to remove the fascia (Fig.D,E,F).

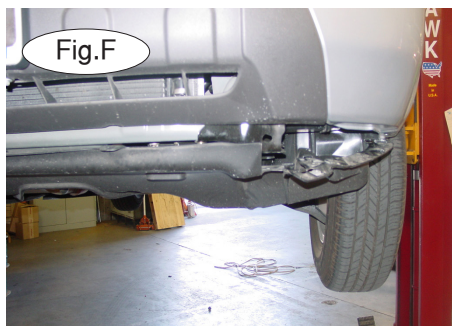

Fig.F

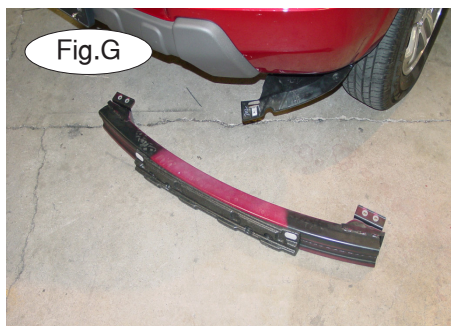

Fig.G



Fig.H

3. Disconnect the ambient air sensor from the bumper core, then remove three 12mm (head) bolts per side and set the bumper core aside (Fig.G). The bumper core will not be reinstalled. *Note:* retain the bumper core and attachment hardware so that it can be replaced in case the bracket is ever removed

4. Remove the headlights (four 10mm head bolts and two plastic fasteners per headlight – Fig.H,I,J).

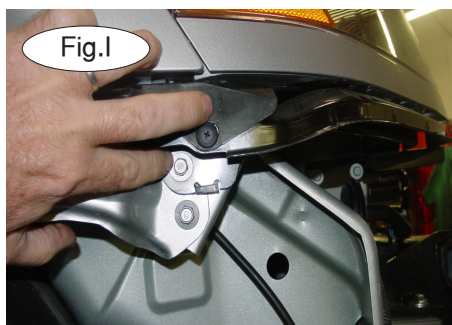

Fig.I

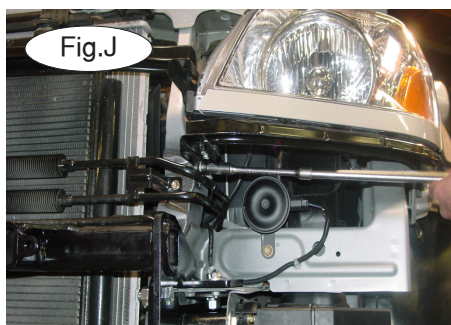

Fig.J



Fig.K

5. Remove the large black air box on the driver's side (two 10mm head bolts – Fig.K). *Note:* on some late model cars, you may not be able to remove the air box. If this is the case, remove the bolts and move the air box off to the side (Fig.L) to allow sufficient working room.

All illustrations and specifications contained herein are based on the latest information available at the time of publication approval. ROADMASTER, INC. reserves the right to make changes at any time without notice in material, specification and models or to discontinue models.



# BASEPLATE KIT INSTALLATION INSTRUCTIONS

**KIT# 1544-1**

02/25  
RS

ROADMASTER, Inc.

6110 NE 127th Ave.

Vancouver, WA 98682

360-896-0407

www.RoadmasterInc.com

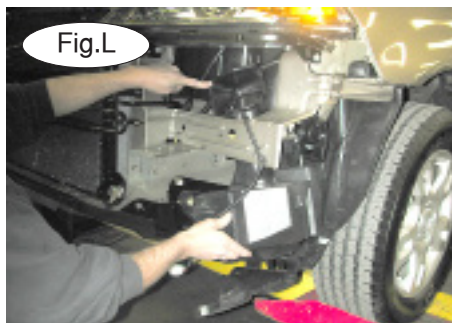

Fig.L

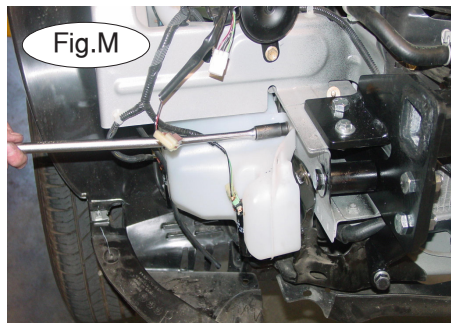

Fig.M

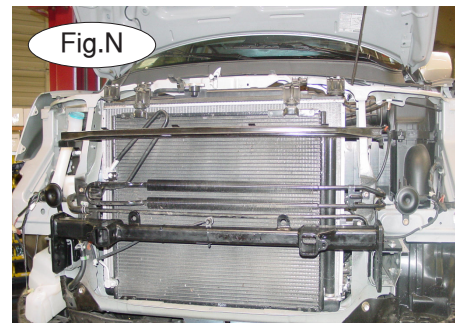

Fig.N

6. Remove three 10mm (head) mounting bolts holding the passenger side washer bottle. This will let you manipulate the bottle for frame access in the next steps (Fig.M).

7. Take the receiver brace and insert each side into the front of the frame opening, with the side mounting plate on top of the frame on each side (Fig.N).

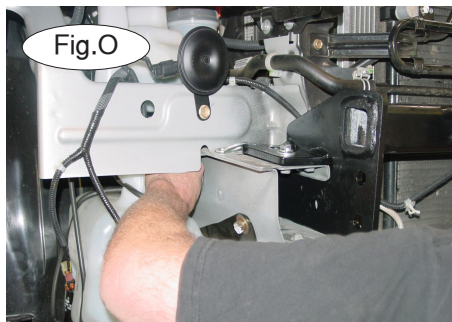

Fig.O

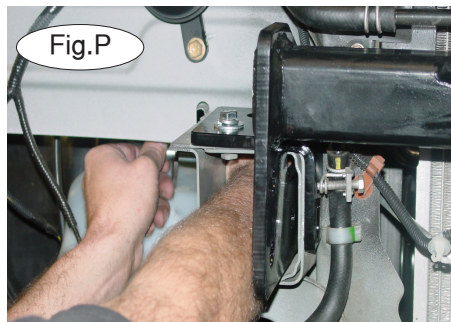

Fig.P

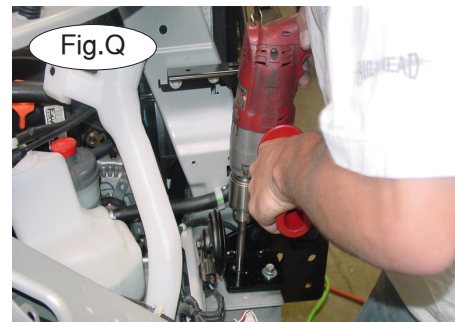

Fig.Q

8. On each side, bolt through the existing holes in the frame and the rear mounting holes in the brace with  $\frac{1}{2}$  x  $4\frac{1}{2}$  inch bolts,  $\frac{1}{2}$  inch plate washers, 2- $\frac{3}{8}$  inch pipe spacers on the inside of the frame and  $\frac{1}{2}$  inch flat washers, lock washers and nuts on the motor side of the frame (Fig.O). Pushing the windshield washer bottle away from the frame on the passenger side will let you access the rear mounting hole.

9. Bolt through the front side plate top mounting hole on each side, using an 8mm x 25mm bolt, lock washer and flat washer (Fig.P).

10. You now have one top mounting hole left in each side of the receiver brace. Using the holes as drill templates, drill a  $\frac{1}{2}$  inch hole through the top of each frame (Fig.Q). Be careful of the transmission and power steering cooling lines on models with towing packages.

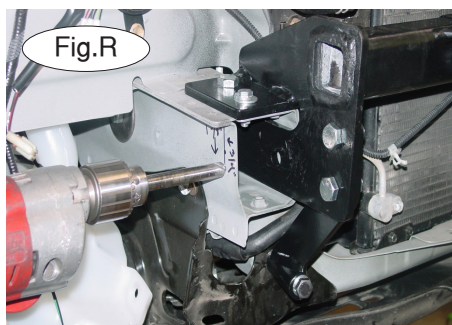

Fig.R



Fig.S



Fig.T

11. Bolt through each top hole with a  $\frac{1}{2}$  x  $1\frac{1}{2}$  inch bolt, plate washer, lock washer and nut. Use the plate washer on the inside of the frame (Fig.R).

12. Now mark a center on the side of each frame rail,  $\frac{5}{8}$  inch from the end and  $1\frac{3}{4}$  inch down from the rail lip (Fig.S). Drill through the outside of the rails into the brace mounting holes with a  $\frac{17}{32}$  inch drill bit (Fig.T).

13. Bolt through in the same way as step 8 with the exception of using a  $\frac{1}{2}$  inch flat washer on the outside of the frame and a beveled 2- $\frac{3}{8}$  inch spacer in the frame. Be careful of the tubing on the inside of the frame on the passenger side (Fig.T).



# BASEPLATE KIT INSTALLATION INSTRUCTIONS

**KIT# 1544-1**

02/25  
RS

ROADMASTER, Inc.

6110 NE 127th Ave.

Vancouver, WA 98682

360-896-0407

www.RoadmasterInc.com

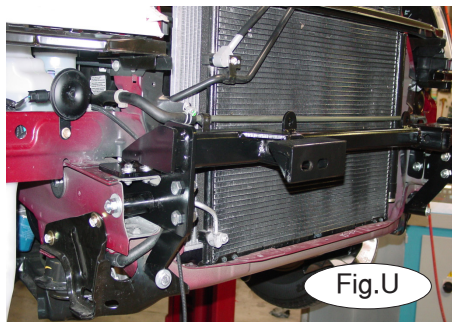

Fig.U

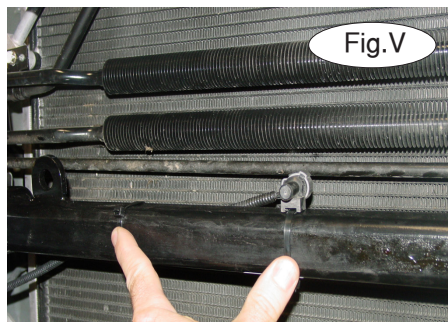

Fig.V



Fig.W

14. Now bolt the lower braces to the receiver brace with two 1/2" x 1 1/2" lock washers and nuts per side. Bolt through the bottoms of the lower braces into existing nuts in the frame with 10mm x 1.25" x 80mm bolts, lock washers and flat washers (Fig.U).

15. Align the receiver brace and torque all mounting bolts to the torque specifications at the bottom of these instructions.

16. Using the included zip ties, attach the ambient air sensor removed in step 3 to the receiver brace as shown (Fig.V).

17. Replace the washer bottle mounting bolts removed in step 6.

18. Remount the driver's side air box removed in step 5.

19. Remount the bumper fascia and mark the grille ribs where the receiver pins will be located, then remove and trim (Honda Pilot only – Fig.W). *Note:* for the Acura MDX only, the bumper fascia will need to be trimmed as indicated in Fig.X.

20. Install the headlights and radiator top cover, reversing steps 1 and 4.

21. Reinstall the bumper fascia, without the bumper core and shock absorption foam (the receiver brace assembly will replace these components), by reversing steps 1 and 2.

22. Insert the front braces into the receiver tubes and secure with 5/8" draw pins and spring pins. *Note:* per the page 1 drawing, the arms will face downward.

23. Install the tow bar according to the manufacturer's instructions.

24. Attach one end of the 10" safety cables to the front holes on the receiver cross bar on each side of the receiver brace with the included cable connectors. Connect the other end to the tow vehicle's safety cables and the tow bar.

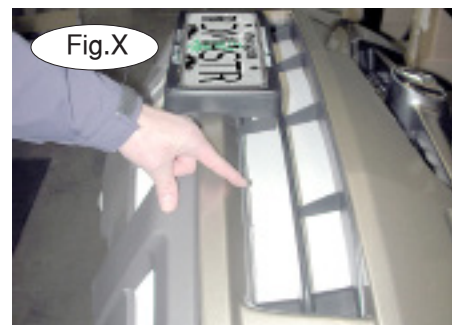

Fig.X

## BOLT TORQUE REQUIREMENTS

Note: The torque values represented below are intended as general guidelines. Torque requirements for specific applications may vary. Roadmaster does not warrant this information to be accurate for all applications and disclaims all liability for any claims or damages which may result from its use.

### STANDARD BOLTS

Thread Size	Grade	Torque
5/16.....	5.....	13 ft./lb.
3/8.....	5.....	23 ft./lb.
7/16.....	5.....	37 ft./lb.
1/2.....	5.....	56 ft./lb.
5/8.....	5.....	150 ft./lb.

### METRIC BOLTS

Thread Size	Grade	Plated / Unplated
8mm-1.0.....	8.8.....	20 ft./lb. 18 ft./lb.
8mm-1.25.....	8.8.....	19 ft./lb. 18 ft./lb.
10mm-1.25.....	8.8.....	38 ft./lb. 36 ft./lb.
10mm-1.5.....	8.8.....	37 ft./lb. 35 ft./lb.

### METRIC BOLTS

Thread Size	Grade	Plated / Unplated
12mm-1.25.....	8.8.....	70 ft./lb. 65 ft./lb.
12mm-1.5.....	8.8.....	66 ft./lb. 61 ft./lb.
12mm-1.75.....	8.8.....	65 ft./lb. 60 ft./lb.
14mm-2.0.....	8.8.....	104 ft./lb. 97 ft./lb.

All illustrations and specifications contained herein are based on the latest information available at the time of publication approval. ROADMASTER, INC. reserves the right to make changes at any time without notice in material, specification and models or to discontinue models.