



# BASEPLATE KIT INSTALLATION INSTRUCTIONS

**KIT# 1545-1**

03/01/16  
KS

ROADMASTER, Inc. 6110 NE 127th Ave. Vancouver, WA 98682 360-896-0407 fax 360-735-9300 www.roadmasterinc.com

ROADMASTER, INC.

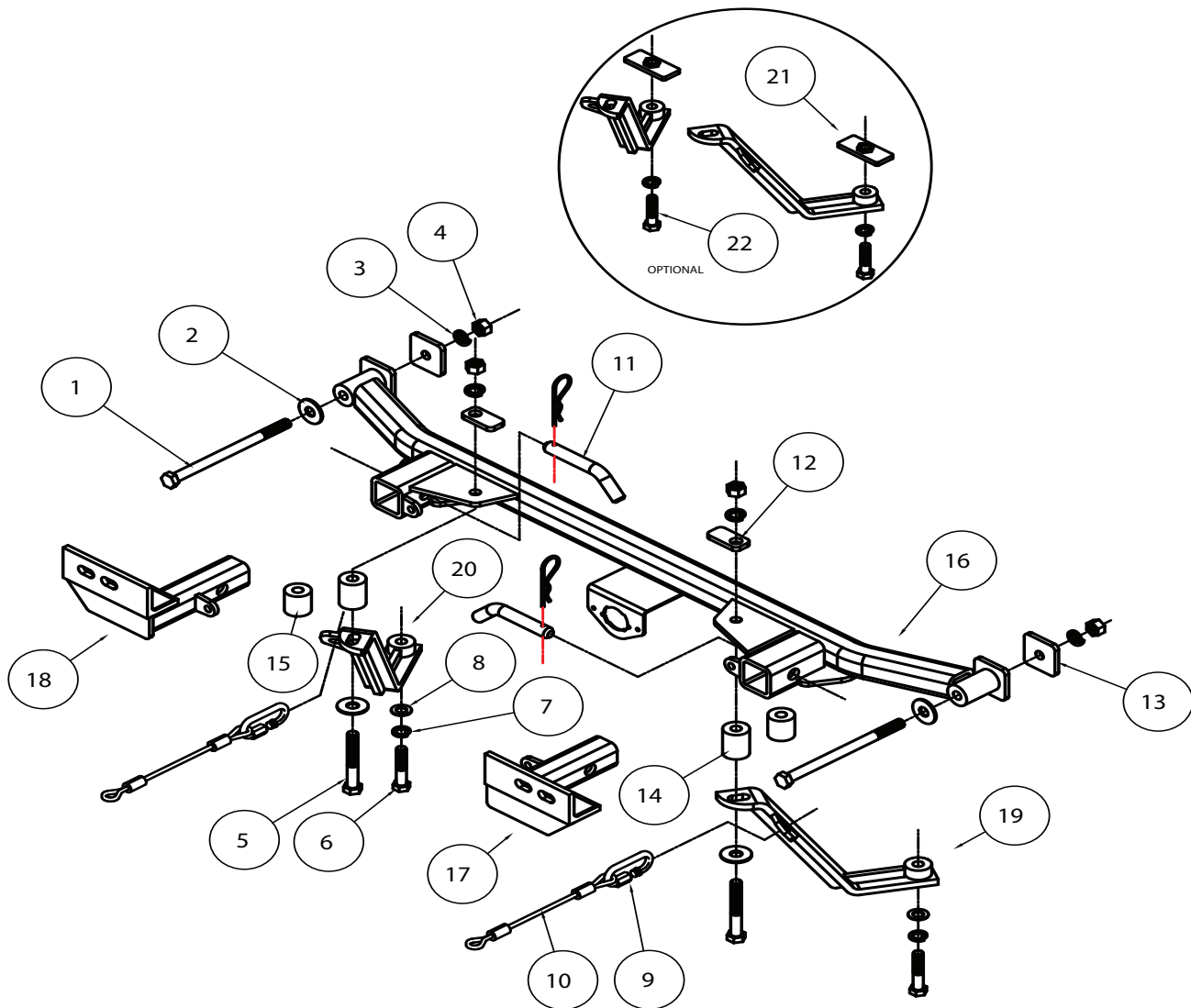

ITEM	QTY	NAME	MATERIAL
1.....	2.....	1/2" x 7 1/2" BOLT.....	350112-00
2.....	4.....	1/2" FLAT WASHER.....	350308-00
3.....	6.....	1/2" LOCK WASHER.....	350309-00
4.....	4.....	1/2" HEX NUT.....	350258-00
5.....	2.....	1/2" x 3 1/2" BOLT.....	350103-00
6.....	2.....	12mm x 1.25 x 60mm BOLT.....	357007-00
7.....	2.....	12mm LOCK WASHER.....	355725-00
8.....	2.....	12mm FLAT WASHER.....	355720-00
9.....	2.....	QUICK LINK.....	200008-00
10.....	2.....	8" SAFETY CABLE.....	650646-08
11.....	2.....	DRAW PIN / SPRING PIN.....	357035-00
12.....	2.....	1/4" x 1" x 2" BACKING PLATE.....	A-000910
13.....	2.....	1/4" x 2" x 2" BACKING PLATE.....	A-001066
14.....	2.....	1 1/4" O.D. x 0.250 x 1 5/8" TUBE SPACER.....	A-001067
15.....	2.....	1 1/4" O.D. x 0.250 x 1 1/4" TUBE SPACER.....	A-000964
16.....	1.....	MAIN RECEIVER.....	C-000503
17.....	1.....	DRIVER SIDE ARM.....	C-000504
18.....	1.....	PASSENGER SIDE ARM.....	C-000505
19.....	1.....	DRIVER SIDE BRACE.....	C-000506
20.....	1.....	PASSENGER SIDE BRACE.....	C-000507
21.....	2.....	1/4" x 1 1/4" x 3" THREADED BACKING PLATE.....	C-000567
22.....	2.....	1/2" x 2" BOLT.....	350097-00



# BASEPLATE KIT INSTALLATION INSTRUCTIONS

**KIT# 1545-1**

03/01/16  
KS

ROADMASTER, Inc. 6110 NE 127th Ave. Vancouver, WA 98682 360-896-0407 fax 360-735-9300 www.roadmasterinc.com

This bracket kit is one of our XL series, which is designed to be partly removable. The kit consists of the main receiver brace, two front arm braces, two lower braces and a hardware pack. The main receiver brace mounts behind the front bumper fascia to the bottom of the bumper core and the front of the frame on each side. The lower braces attach to the front of the radiator support and lower subframe mount on each side. The front arm braces insert into the receivers on each side (Fig.A).

Start by laying the kit out according to the illustration. This will give you a visual idea of how the kit installs and also confirm that all the components are present and accounted for.



**IMPORTANT:** All baseplates **must** be assembled with all the bolts left loose for final adjustment and positioning (before tightening) unless otherwise instructed. All bolts **must** be torqued for proper strength. If more than one bolt is used per fastening point, the diagram may only show one. Use flat washers over all slotted holes and lock washers on all fasteners.

## WARNING

Failure to heed these warnings or follow the installation instructions may result in a voided warranty, loss of towed vehicle, personal injury or death.

- Do not weld or modify this baseplate or its components. Welding or modification will void the warranty.
- Do not use this document as a basis to design/fabricate a baseplate, as it may not show all parts or structural components.
- We strongly recommend professional installation.
- If the towed vehicle has been in an accident, it must be properly repaired before attaching the baseplate. Do not install the baseplate if any structural frame damage is found.
- The installer must use all bolts and parts supplied. If running changes were made by the vehicle manufacturer after this kit was designed, some bolts or other fasteners may no longer be the correct size. It is the installer's responsibility to verify this kit is securely fastened to the vehicle.
- Use Loctite® Red on all bolts used to secure this baseplate. Torque all bolts to the specifications found at the end of these instructions. Do not over-torque the bolts or failure may occur.
- The installer must inspect the baseplate to ensure adequate clearance, particularly around hoses, air conditioner lines, radiators, etc. or non-warranty failure may result.
- Roadmaster manufactures many styles of baseplates. If your baseplate has removable arms, they must be removed before driving the vehicle, unless the arms can be pinned or padlocked in place. If not secured, the arms could vibrate out.
- Some motorhome chassis have such a tight turning radius that you can damage your motorhome, towed vehicle, tow bar or baseplate while turning sharply. Before getting on the road, test your turning radius in an empty parking lot. Turning too sharply could result in non-warranty damage to your towing system, motorhome and/or towed vehicle.
- Do not back up with the towed vehicle attached or non-warranty damage will occur to your towing system or vehicles.
- The safety cables must connect the towing vehicle to the towed vehicle frame to frame, with the cables crossed, with enough slack for sharp turns. See cable instructions for proper routing. Failure to do so will result in non-warranty damage and/or the loss of the towed vehicle.
- This kit is designed for use with ROADMASTER tow bars and ROADMASTER adapters only. Using this kit with other brands, without an approved ROADMASTER adapter, may result in non-warranty damage or injury.
- Receiver extensions and out-of-level towing situations of 3 inches or more. This can cause the system to swing much higher and lower, causing excessive strain on the tow bar, baseplate and frame. That can cause the towing system to fail, causing property damage, personal injury or even death. If you must use a receiver extension or drop hitch to tow, it will reduce your receiver's weight capacity by 1/3 to avoid damaging your system. Never use more than one extension and/or drop hitch, as this will void your warranty.
- Every 3,000 miles, the owner must inspect all mounting points for cracks or fatigue, and check the fasteners for proper torque, according to the bolt torque requirements chart on the last page of these instructions.
- The owner must follow the vehicle manufacturer's instructions to prepare the vehicle for towing. Failure to do so may cause severe damage to the vehicle.
- This baseplate is only warranted for the original installation. Installing a used baseplate on another vehicle is not recommended and will void the warranty.





# BASEPLATE KIT INSTALLATION INSTRUCTIONS

**KIT# 1545-1**

03/01/16  
KS

ROADMASTER, Inc. 6110 NE 127th Ave. Vancouver, WA 98682 360-896-0407 fax 360-735-9300 www.roadmasterinc.com

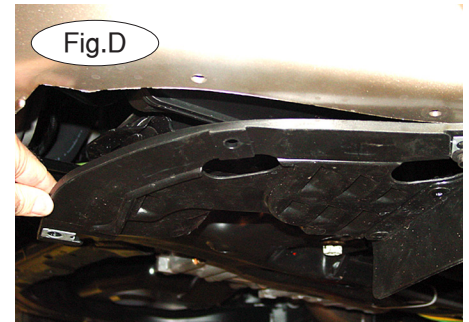
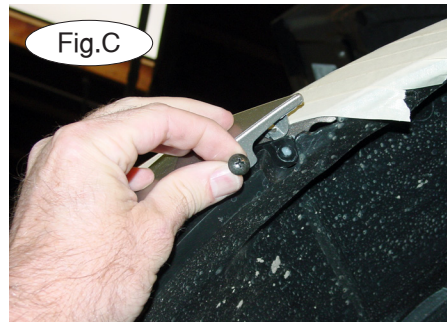
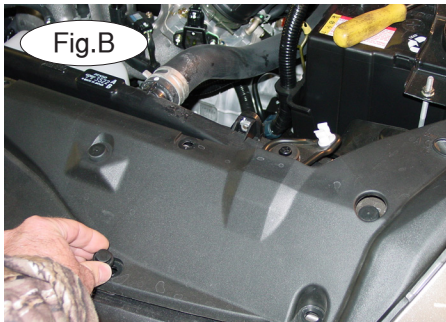

1. **Important:** please use all supplied bolts and parts and read all instructions carefully before beginning this installation. The majority of questions you may have can be answered within the text, and proper installation will ensure safe and secure travel. Now, begin the installation. Remove the ten plastic fasteners holding the top black plastic grille cover on the top of the fascia and set the cover aside (Fig.B). *Note:* some models will not have a grille cover, and the fastener count will differ.

2. Move to the junction of the fenders and the fascia and remove a Phillips head screw (Fig.C) on each side then two lower 10mm (head) fasteners and a plastic snap fastener (Fig.D). Remove four more plastic fasteners in the bottom of the fascia and pull forward to remove. *Note:* the fascia fits into clips under and around the headlights and will take a sharp tug to remove (Fig.E).

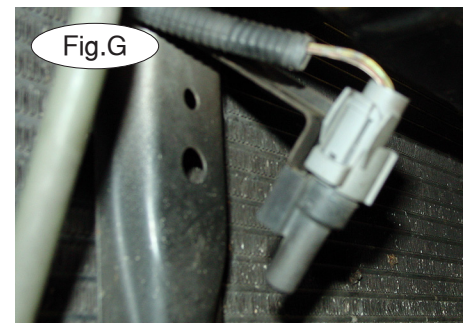
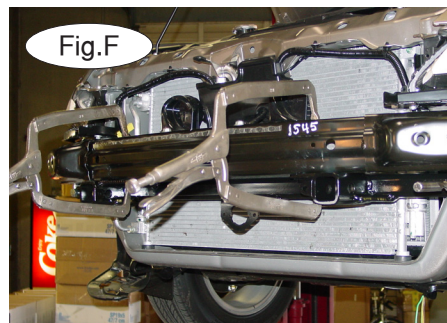

3. Hold the main receiver brace to the bottom of the bumper core against the front of the frame on each side and clamp in place as pictured. *Note:* 6" C clamps will work best here. Make certain the brace is centered and snug against the front of the frame (Fig.F). *Note:* some vehicles may have an ambient air sensor, which can be displaced to clear the brace as shown (Fig.G).

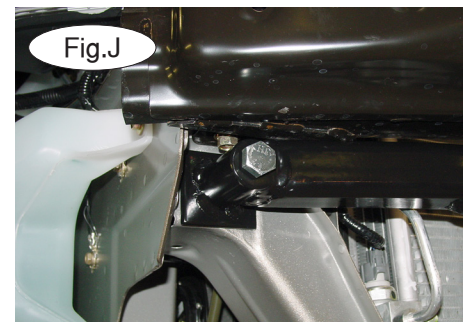
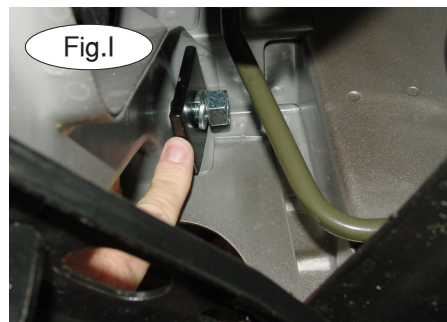
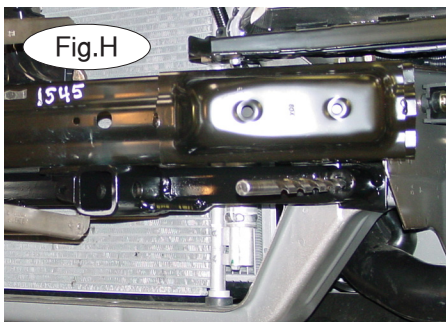

4. Using the receiver brace as a template drill a hole through the front of the frame on each side (Fig.H).

5. Bolt through the frames with  $\frac{1}{2}$ " x  $7\frac{1}{2}$ " bolts, flat washers,  $\frac{1}{4}$ " x 2" x 2" backing plates, lock washers and nuts (Fig.I,J). Tighten these bolts. *Note:* due to manufacturing variances, you may need to drill out a small piece of the flange in order to allow the  $\frac{1}{4}$ " x 2" x 2" backing plates to sit flush on the frame rail.





# BASEPLATE KIT INSTALLATION INSTRUCTIONS

**KIT# 1545-1**

03/01/16  
KS

ROADMASTER, Inc. 6110 NE 127th Ave. Vancouver, WA 98682 360-896-0407 fax 360-735-9300 www.roadmasterinc.com

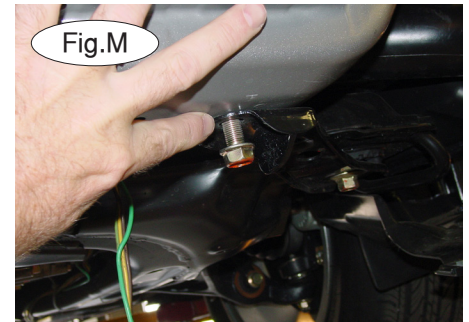
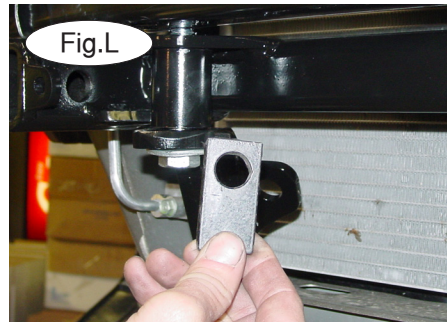
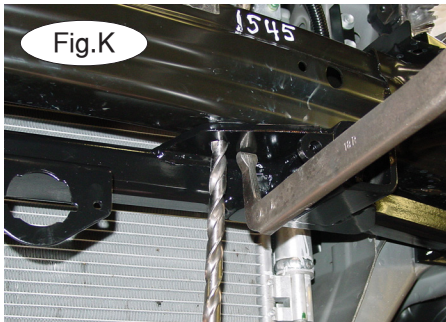

6. Now, using the receiver brace as a drill template again, drill two holes through the bottom of the bumper core (Fig.K).
7. Insert two  $\frac{1}{4}$ " x 1" x 2" backing plates into the bumper core over the drilled holes (Fig.L).

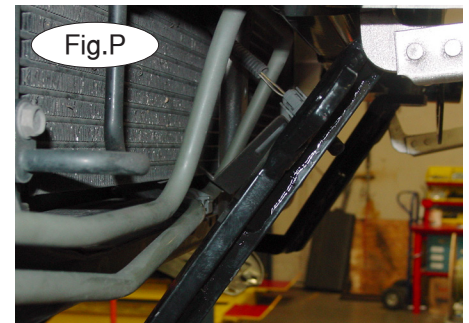
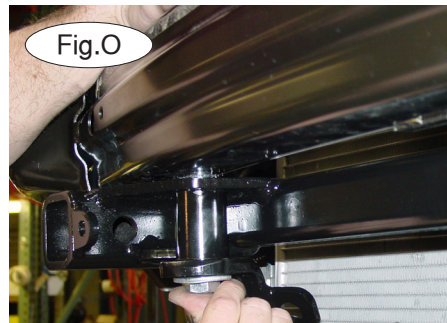
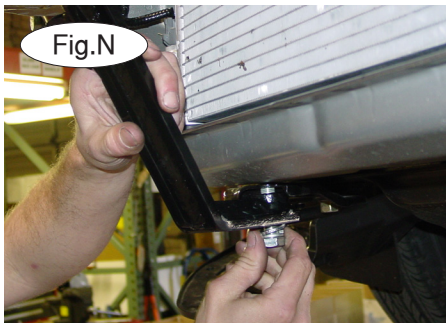

8. Remove the front inside 17mm (head) bolt from the subframe mount on each side (Fig.M). *Note* : some models don't have the subframe brace or bolt. If this is the case, place a piece of metal between the radiator and cross member to protect the engine components and ream the existing hole to  $\frac{1}{2}$ ". Place the optional  $\frac{1}{4}$ " x  $1\frac{1}{4}$ " x 3" threaded backing plate on the top side of the lower brace and use the optional included  $\frac{1}{2}$ " x 2" bolts to bolt up through the lower brace and into the threaded backing plate.

9. Hold the lower braces for each side over these mounting holes as illustrated and bolt into place with 12mm x 1.25 x 60mm bolts, lock washers, and flat washers (Fig.N). Bolt through the tops of the bottom braces,  $1\frac{5}{8}$ " or  $1\frac{1}{4}$ " spacers, the receiver brace and the bottom of the bumper core and the backing plates with  $\frac{1}{2}$ " x  $3\frac{1}{2}$ " bolts, lock washers and nuts (Fig.O). *Note*: some models will require displacing the power steering cooling line slightly to clear the lower braces (Fig.P). Some models will require different length tube spacers.

10. Torque all bolts to the bolt torque requirements found at the end of these instructions.

11. Replace the bumper foam and trial fit the fascia. Mark the trim areas around the lower brace then remove and trim (Fig.Q).

12. Trim the lower center splash panel to fit around the lower braces (Fig.R), then reinstall the fascia reversing steps 2 and 3. Additional minor trimming in the grille may be required on some models.

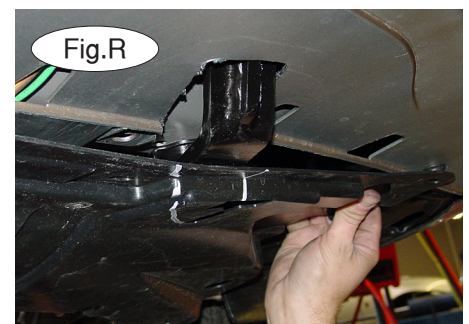
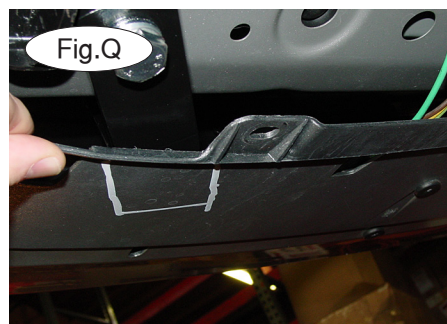



# BASEPLATE KIT INSTALLATION INSTRUCTIONS

**KIT# 1545-1**

03/01/16  
KS

ROADMASTER, Inc. 6110 NE 127th Ave. Vancouver, WA 98682 360-896-0407 fax 360-735-9300 www.roadmasterinc.com

- 13. 2006-2007 models require trimming on the inside edge of the grille above the receiver (Fig.S).
- 14. Insert the front braces into the receiver tubes and pin with 5/8" draw pins and spring pins.
- 15. Install the tow bar according to the manufacturer's instructions.
- 16. Attach one end of the 8" safety cables to front holes on the receiver cross bar on each side of the receiver brace with the included cable connectors. Connect the other end to the tow vehicle's safety cables and tow bar.

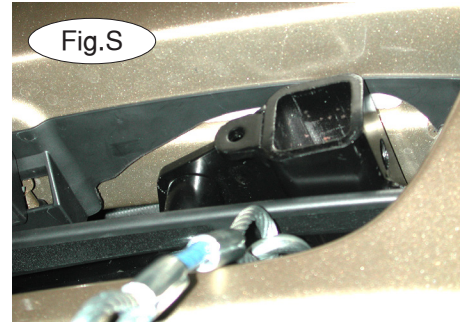

## BOLT TORQUE REQUIREMENTS

Note: The torque values represented below are intended as general guidelines. Torque requirements for specific applications may vary. Roadmaster does not warrant this information to be accurate for all applications and disclaims all liability for any claims or damages which may result from its use.

### STANDARD BOLTS

Thread Size	Grade	Torque
5/16.....	5.....	13 ft./lb.
3/8.....	5.....	23 ft./lb.
7/16.....	5.....	37 ft./lb.
1/2.....	5.....	56 ft./lb.
5/8.....	5.....	150 ft./lb.

### METRIC BOLTS

Thread Size	Grade	Plated / Unplated
8mm-1.0 .....	8.8 .....	20 ft./lb. 18 ft./lb.
8mm-1.25 .....	8.8 .....	19 ft./lb. 18 ft./lb.
10mm-1.25 .....	8.8 .....	38 ft./lb. 36 ft./lb.
10mm-1.5 .....	8.8 .....	37 ft./lb. 35 ft./lb.

### METRIC BOLTS

Thread Size	Grade	Plated / Unplated
12mm-1.25 .....	8.8 .....	70 ft./lb. 65 ft./lb.
12mm-1.5 .....	8.8 .....	66 ft./lb. 61 ft./lb.
12mm-1.75 .....	8.8 .....	65 ft./lb. 60 ft./lb.
14mm-2.0 .....	8.8 .....	104 ft./lb. 97 ft./lb.

All illustrations and specifications contained herein are based on the latest information available at the time of publication approval. ROADMASTER, INC. reserves the right to make changes at any time without notice in material, specification and models or to discontinue models.