

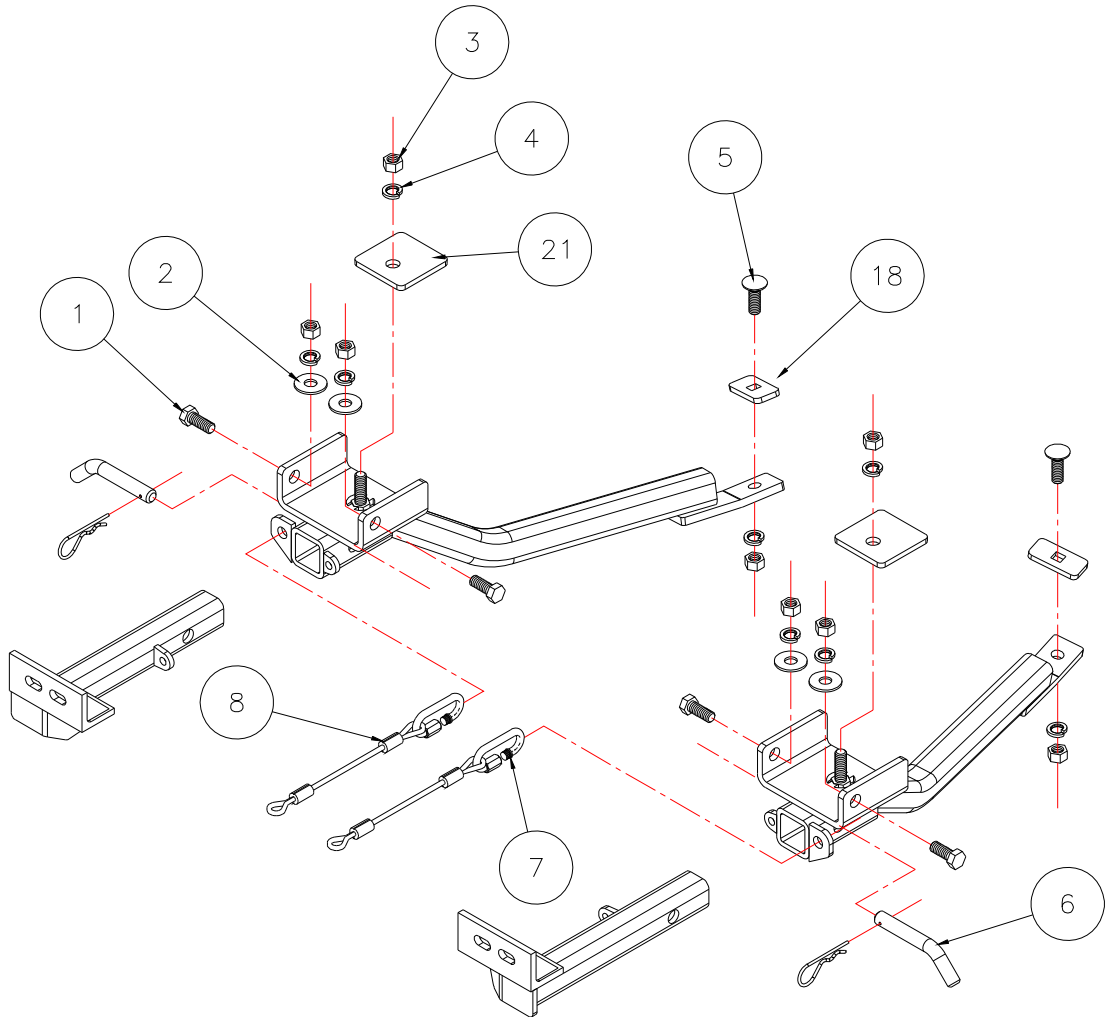

BASEPLATE KIT INSTALLATION INSTRUCTIONS

KIT# 199-10
12/13/10
KS

ROADMASTER, Inc. 6110 NE 127th Ave. Vancouver, WA 98682 1-800-669-9690 fax 360-735-9300 www.roadmasterinc.com



Item	Qty	Length	Width	Name	Part No.
1	4	1 1/4"	1/2"	BOLT	350094-00
2	4		1/2"	FLAT WASHER	350308-00
3	8		1/2"	NUT	350258-00
4	8		1/2"	LOCK WASHER	350309-00
5	2	1 1/2"	1/2"	CARRIAGE BOLT	350362-00
6	2			DRAW PIN / SPRING PIN	357035-00
7	2			CONNECTORS	200008-00
8	2	10"		SAFETY CABLES, 8,000 lb. rated	650648-10
18	2	2 1/2"	1 1/2"	1/4" BACKING PLATE	A-000084
21	2	3"	3"	1/4" BACKING PLATE	A-000432



BASEPLATE KIT INSTALLATION INSTRUCTIONS

KIT# 199-10
12/13/10
KS

ROADMASTER, Inc. 6110 NE 127th Ave. Vancouver, WA 98682 1-800-669-9690 fax 360-735-9300 www.roadmasterinc.com

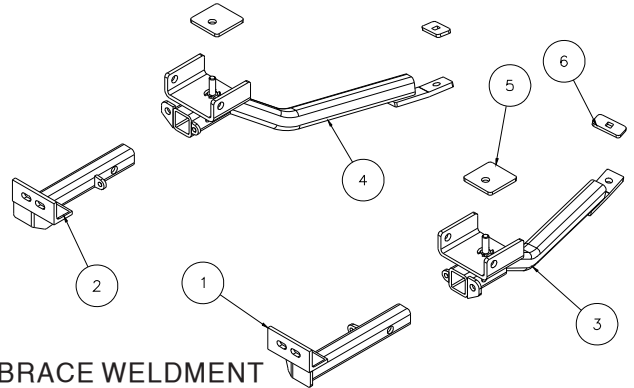

Item	Qty	Name	Parts
1	1	C-000555	DRIVER SIDE RECEIVER BRACE WELDMENT
2	1	C-000556	PASSENGER SIDE RECEIVER BRACE WELDMENT
3	1	C-000221	DRIVER SIDE ARM WELDMENT
4	1	C-000222	PASSENGER SIDE ARM WELDMENT
5	2	A-000432	3 x 3 BACKING PLATE
6	2	A-000084	1 1/2 x 2 1/2 SQUARE HOLE BACKING PLATE

IMPORTANT: All baseplates **must** be assembled with all the bolts left loose for final adjustment and positioning (before tightening) unless otherwise instructed. All bolts **must** be torqued for proper strength. If more than one bolt is used per fastening point, the diagram may only show one. Use flat washers over all slotted holes and lock washers on all fasteners.

WARNING

Failure to heed these warnings or follow the installation instructions may result in a voided warranty, loss of towed vehicle, personal injury or death.

- Do not weld or modify this baseplate or its components. Welding or modification will void the warranty.
- Do not use this document as a basis to design/fabricate a baseplate, as it may not show all parts or structural components.
- We strongly recommend professional installation.
- If the towed vehicle has been in an accident, it must be properly repaired before attaching the baseplate. Do not install the baseplate if any structural frame damage is found.
- The installer must use all bolts and parts supplied. If running changes were made by the vehicle manufacturer after this kit was designed, some bolts or other fasteners may no longer be the correct size. It is the installer's responsibility to verify this kit is securely fastened to the vehicle.
- Use Loctite® Red on all bolts used to secure this baseplate. Torque all bolts to the specifications found at the end of these instructions. Do not over-torque the bolts or failure may occur.
- The installer must inspect the baseplate to ensure adequate clearance, particularly around hoses, air conditioner lines, radiators, etc. or non-warranty failure may result.
- Roadmaster manufactures many styles of baseplates. If your baseplate has removable arms, they must be removed before driving the vehicle, unless the arms can be pinned or padlocked in place. If not secured, the arms could vibrate out.
- Some motorhome chassis have such a tight turning radius that you can damage your motorhome, towed vehicle, tow bar or baseplate while turning sharply. Before getting on the road, test your turning radius in an empty parking lot. Turning too sharply could

result in non-warranty damage to your towing system, motorhome and/or towed vehicle.

- Do not back up with the towed vehicle attached or non-warranty damage will occur to your towing system or vehicles.
- The safety cables must connect the towing vehicle to the towed vehicle frame to frame, with the cables crossed, with enough slack for sharp turns. See cable instructions for proper routing. Failure to do so will result in non-warranty damage and/or the loss of the towed vehicle.
- This kit is designed for use with ROADMASTER tow bars and ROADMASTER adapters only. Using this kit with other brands, without an approved ROADMASTER adapter, may result in non-warranty damage or injury.
- Receiver extensions and out-of-level towing situations of 3 inches or more. This can cause the system to swing much higher and lower, causing excessive strain on the tow bar, baseplate and frame. That can cause the towing system to fail, causing property damage, personal injury or even death. If you must use a receiver extension or drop hitch to tow, it will reduce your receiver's weight capacity by 1/3 to avoid damaging your system. Never use more than one extension and/or drop hitch, as this will void your warranty.
- Every 3,000 miles, the owner must inspect all mounting points for cracks or fatigue, and check the fasteners for proper torque, according to the bolt torque requirements chart on the last page of these instructions.
- The owner must follow the vehicle manufacturer's instructions to prepare the vehicle for towing. Failure to do so may cause severe damage to the vehicle.
- This baseplate is only warranted for the original installation. Installing a used baseplate on another vehicle is not recommended and will void the warranty.



BASEPLATE KIT INSTALLATION INSTRUCTIONS

KIT# 199-10
12/13/10
KS

ROADMASTER, Inc. 6110 NE 127th Ave. Vancouver, WA 98682 1-800-669-9690 fax 360-735-9300 www.roadmasterinc.com

1. **Important:** please use all supplied bolts and parts and read all instructions carefully before beginning this installation. The majority of questions you may have can be answered within the text, and proper installation will ensure safe and secure travel. Now, begin the installation. This bracket kit is one of our XL series, which is designed to be partly removable. The kit consists of two main receiver braces, front braces and a hardware pack. The main receiver braces mount below the front bumper fascia to the front frame tubes and frame cross member. The front braces insert into the receiver brace on each side. Start by laying the kit out according to the illustration. This will give you a visual idea of how the kit installs and also confirm that the kit components are present and accounted for.

2. To gain access to the mounting area, remove the front grille and bumper.
3. Locate the front tow hooks in the frame tubes and remove. The front of the receiver braces will utilize this mounting area.
4. Insert a 1/4" x 3" x 3" backing plate in the front of each frame tube so that the hole lines up with the existing hole in the bottom of each frame tube. The hole in the backing plate is closer to the front of the plate than the back. Install with the front forward. Hold a receiver brace to the bottom of the front frame tube and bolt in place using two 1/2" nuts and lock washers. Install the remaining receiver brace then tighten to hold the positioning.
5. Bolt through the sides of the receiver braces and frame tubes with 1/2" x 1 1/4" bolts, flat washers, lock washers and nuts. Be sure to use flat washers on the inside of the frame tubes.
6. Install the front braces and pin in position. Check the front alignment across the mounting face, adjust if needed, then tighten all mounting bolts to maintain alignment.
7. Using the receiver braces as drilling templates, drill a 17/32" hole through each side of the front frame cross member.
8. Bolt through the frame cross member and receiver braces on each side with a 1/2" x 1 1/2" carriage bolt, 1/4" x 1 1/2" x 2 1/2" sq. holed backing plate, lock washer and nut. Be sure to use the backing plate inside the sub frame. A large access hole in the front of the sub frame on each side will provide the needed access.
9. Torque all mounting bolts to the specifications below.
10. Remove the front braces from the receiver tubes and reinstall the bumper and grille.
11. Install the front braces and secure with 5/8" draw pins and 1/8" spring pins.
12. Install the tow bar according to the manufacturer's instructions.
13. Attach one end of the included 10" safety cables to the front hole in the side mounting plate on each side of the receiver brace with the included cable connectors. Connect the other end to the tow vehicle's safety cables and the tow bar.

BOLT TORQUE REQUIREMENTS

Note: The torque values represented below are intended as general guidelines. Torque requirements for specific applications may vary. Roadmaster does not warrant this information to be accurate for all applications and disclaims all liability for any claims or damages which may result from its use.

STANDARD BOLTS			METRIC BOLTS			METRIC BOLTS		
Thread Size	Grade	Torque	Thread Size	Grade	Plated / Unplated	Thread Size	Grade	Plated / Unplated
5/16	5	13 ft./lb.	8mm-1.0	8.8	20 ft./lb. 18 ft./lb.	12mm-1.25	8.8	70 ft./lb. 65 ft./lb.
3/8	5	23 ft./lb.	8mm-1.25	8.8	19 ft./lb. 18 ft./lb.	12mm-1.5	8.8	66 ft./lb. 61 ft./lb.
7/16	5	37 ft./lb.	10mm-1.25	8.8	38 ft./lb. 36 ft./lb.	12mm-1.75	8.8	65 ft./lb. 60 ft./lb.
1/2	5	56 ft./lb.	10mm-1.5	8.8	37 ft./lb. 35 ft./lb.	14mm-2.0	8.8	104 ft./lb. 97 ft./lb.
5/8	5	150 ft./lb.						

All illustrations and specifications contained herein are based on the latest information available at the time of publication approval. ROADMASTER, INC. reserves the right to make changes at any time without notice in material, specification and models or to discontinue models.