



BASEPLATE KIT INSTALLATION INSTRUCTIONS

KIT# 2505-3

11/2025
MS

ROADMASTER, Inc.

6110 NE 127th Ave.

Vancouver, WA 98682

360-896-0407

www.RoadmasterInc.com

Important

Note: this bracket will not accommodate the Guardian rock shield, some models of the Tow Defender, Stowaway or the StowMaster and StowMaster All Terrain tow bars.

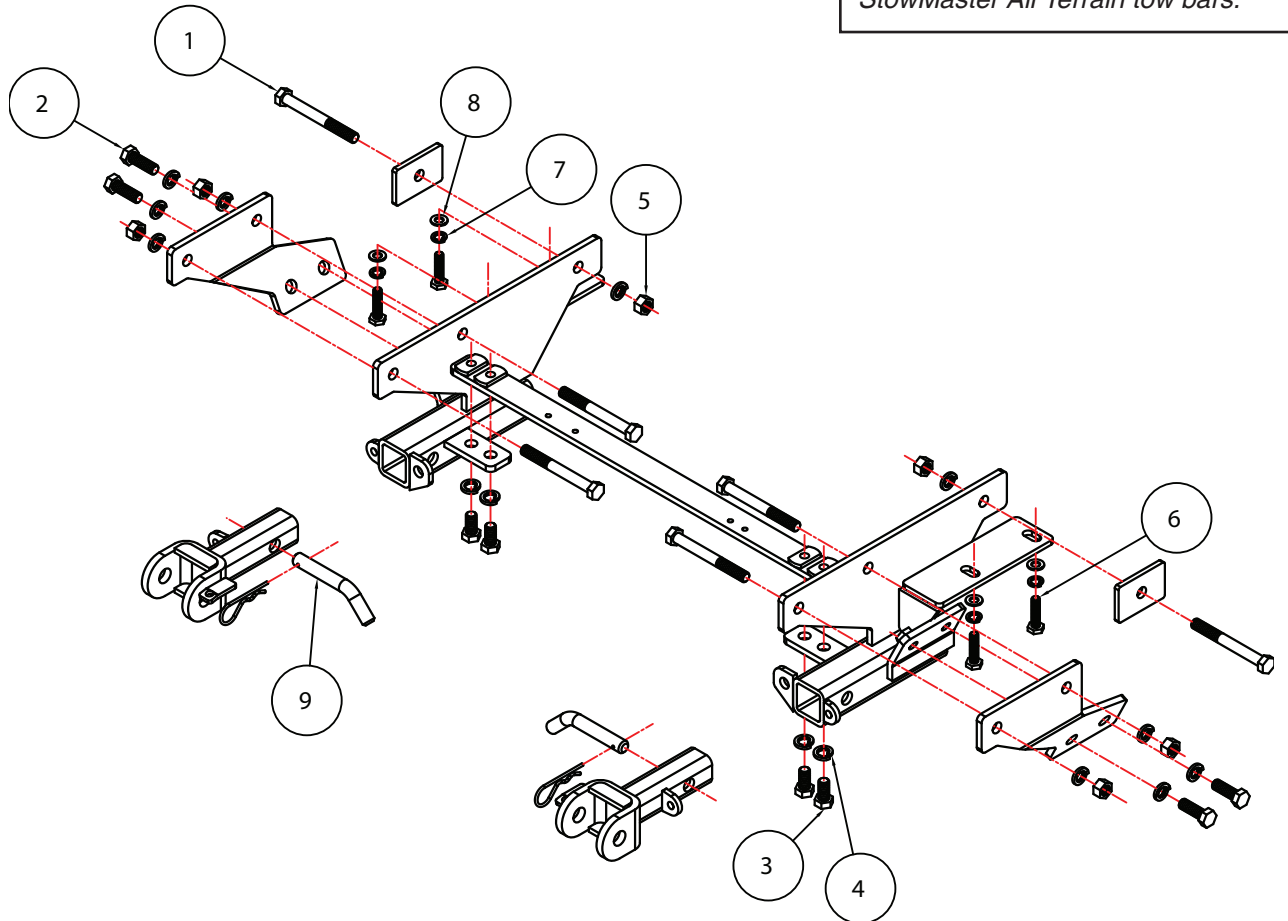

Item	Qty.	Length	Width	Description	Part#
1	6	4 1/2"	1/2"	1/2" x 4 1/2" BOLTS	350106-00
2	4	1 1/2"	1/2"	BOLT	350095-00
3	4	1"	1/2"	BOLT	350093-00
4	14		1/2"	LOCK WASHER	350309-00
5	6		1/2"	NUT	350258-00
6	4	40mm	10mm	10mm x 1.5 x 40mm BOLT	356103-00
7	4		10mm	LOCK WASHER	355715-00
8	4		10mm	FLAT WASHER	355710-00
9	2		5/8"	DRAW PINS, SPRING PINS	357035-00



BASEPLATE KIT INSTALLATION INSTRUCTIONS

KIT# 2505-3

11/2025
MS

ROADMASTER, Inc.

6110 NE 127th Ave.

Vancouver, WA 98682

360-896-0407

www.RoadmasterInc.com

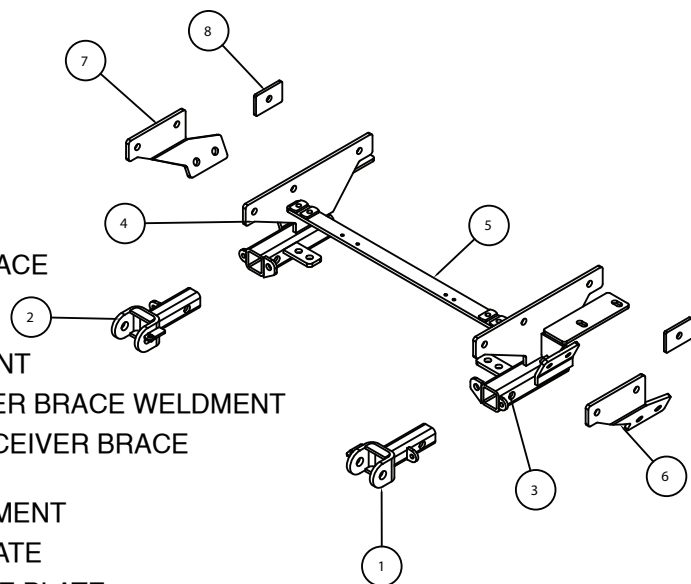

Item	Qty.	Part #	Description
1.....	1	C-001118.....	DRIVER SIDE ARM BRACE WELDMENT
2.....	1	C-001119.....	PASSENGER SIDE ARM BRACE WELDMENT
3.....	1	C-001280	DRIVER SIDE RECEIVER BRACE WELDMENT
4.....	1	C-001281	PASSENGER SIDE RECEIVER BRACE WELDMENT
5.....	1	C-001284	CROSS BRACE WELDMENT
6.....	1	B-000868.....	DRIVER SIDE SIDE PLATE
7.....	1	B-000869.....	PASSENGER SIDE SIDE PLATE
8.....	2	A-000147.....	2" x 3" BACKING PLATE ROUND HOLE

IMPORTANT: All baseplates *must* be assembled with all the bolts left loose for final adjustment and positioning (before tightening) unless otherwise instructed. All bolts *must* be torqued for proper strength. If more than one bolt is used per fastening point, the diagram may only show one. Use flat washers over all slotted holes and lock washers on all fasteners.

WARNING

Failure to heed these warnings or follow the installation instructions may result in a voided warranty, loss of towed vehicle, personal injury or death.

- Do not weld or modify this baseplate or its components. Welding or modification will void the warranty.
- Do not use this document as a basis to design/fabricate a baseplate, as it may not show all parts or structural components.
- We strongly recommend professional installation.
- If the towed vehicle has been in an accident, it must be properly repaired before attaching the baseplate. Do not install the baseplate if any structural frame damage is found.
- The installer must use all bolts and parts supplied. If running changes were made by the vehicle manufacturer after this kit was designed, some bolts or other fasteners may no longer be the correct size. It is the installer's responsibility to verify this kit is securely fastened to the vehicle.
- Use Threadlocker Red on all bolts used to secure this baseplate. Torque all bolts to the specifications found at the end of these instructions. Do not over-torque the bolts or failure may occur.
- The installer must inspect the baseplate to ensure adequate clearance, particularly around hoses, air conditioner lines, radiators, etc. or non-warranty failure may result.
- Roadmaster manufactures many styles of baseplates. If your baseplate has removable arms, they must be removed before driving the vehicle, unless the arms can be pinned or padlocked in place. If not secured, the arms could vibrate out.
- Some motorhome chassis have such a tight turning radius that you can damage your motorhome, towed vehicle, tow bar or baseplate while turning sharply. Before getting on the road, test your turning radius in an empty parking lot. Turning too sharply could

result in non-warranty damage to your towing system, motorhome and/or towed vehicle.

- Do not back up with the towed vehicle attached or non-warranty damage will occur to your towing system or vehicles.
- The safety cables must connect the towing vehicle to the towed vehicle frame to frame, with the cables crossed, with enough slack for sharp turns. See cable instructions for proper routing. Failure to do so will result in non-warranty damage and/or the loss of the towed vehicle.
- This kit is designed for use with ROADMASTER tow bars and ROADMASTER adapters only. Using this kit with other brands, without an approved ROADMASTER adapter, may result in non-warranty damage or injury.
- Receiver extensions and out-of-level towing situations of 3" or more can cause the system to swing much higher and lower, causing excessive strain on the tow bar, baseplate and frame. That can cause the towing system to fail, causing property damage, personal injury or even death. If you must use a receiver extension or drop hitch to tow, it will reduce your receiver's the towing system's capacity by 1/3 to avoid damaging your system. Never use more than one extension and/or drop hitch, as this will void your warranty.
- Every 3,000 miles, the owner must inspect all mounting points for cracks or fatigue, and check the fasteners for proper torque, according to the bolt torque requirements chart on the last page of these instructions.
- The owner must check and follow the vehicle manufacturer's instructions to prepare the vehicle for towing. Failure to do so may cause severe damage to the vehicle.
- This baseplate is only warranted for the original installation. Installing a used baseplate on another vehicle is not recommended and will void the warranty.



BASEPLATE KIT INSTALLATION INSTRUCTIONS

KIT# 2505-3

11/2025
MS

ROADMASTER, Inc.

6110 NE 127th Ave.

Vancouver, WA 98682

360-896-0407

www.RoadmasterInc.com

This is one of our MX series brackets, which allows the visible front portion of the brackets to be easily removed from the front of the vehicle (Fig.A and Fig.B). The bracket consists of two main receiver braces, two side braces, a center brace, two removable front braces and a hardware pack.

The main receiver brace mounts to the frame and the sway bar mounts, the side braces mount to the frame rail and the main braces, and the center brace mounts to the main braces. The removable front braces install in the main receiver braces.

Before starting the installation, lay out the kit components in order, as they will be used. This will give you a visual idea of how the components work, and will also confirm that everything is present and accounted for.

1. **Important:** please use all supplied bolts and parts and read all instructions carefully before beginning this installation. The majority of questions you may have can be answered within the text, and proper installation will ensure safe and secure travel. Now, begin the installation by removing two plastic fasteners (one on each side), holding the fender liner to the frame. They are at slightly different locations. Figure C shows the driver side and Figure D shows the passenger side plastic fastener.

2. Next, remove four 13mm bolts holding the rock guard to the bumper and the subframe (Fig.E). Remove the rock guard.

3. Remove four 10mm (head) bolts (two on each side) holding the sway bar bushings to the frame rail (Fig.F). Allow the sway bar to hang from its remaining attachment points (Fig.G).

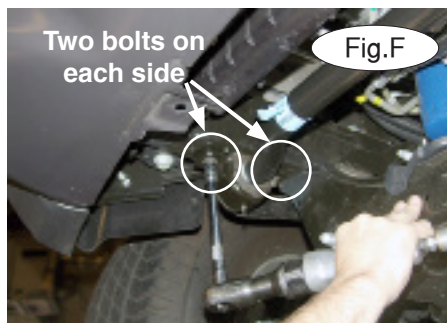
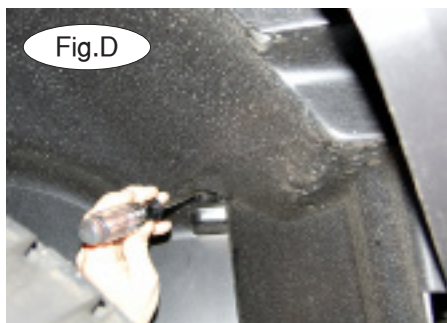
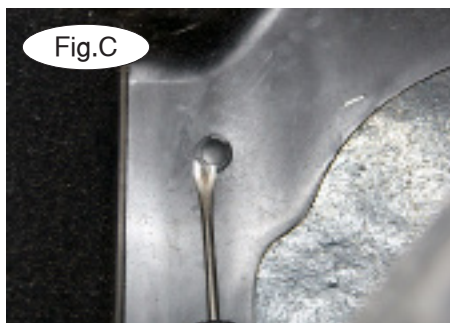



BASEPLATE KIT INSTALLATION INSTRUCTIONS

KIT# 2505-3

11/2025
MS

ROADMASTER, Inc.

6110 NE 127th Ave.

Vancouver, WA 98682

360-896-0407

www.RoadmasterInc.com

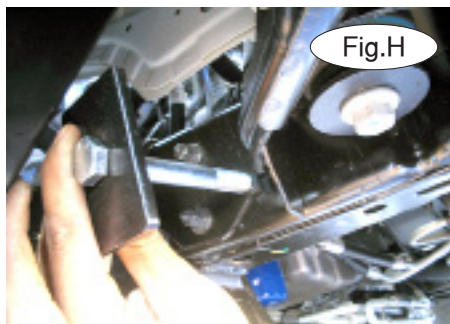

Fig.H

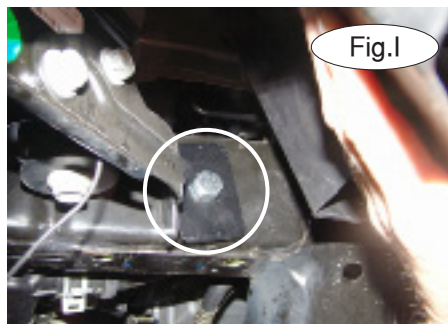

Fig.I

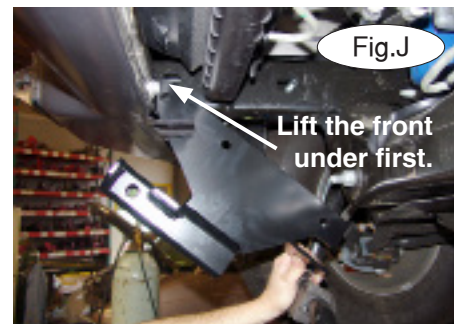

Fig.J

Lift the front under first.

4. If your vehicle is equipped with an auxiliary air pump (passenger side), the lower front corner of the mounting bracket must be trimmed to gain access to the slot (Fig.H). Now, Insert one of the $\frac{1}{2}$ " x $4\frac{1}{2}$ " bolts through one of the $\frac{1}{4}$ " x 2" x 3" backing plates (9/16" hole). Then, pull back the fender liner, and insert the bolt and the backing plate through the existing slot in the frame rail (Fig.I).

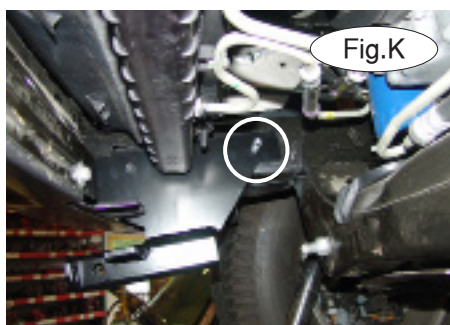

Fig.K

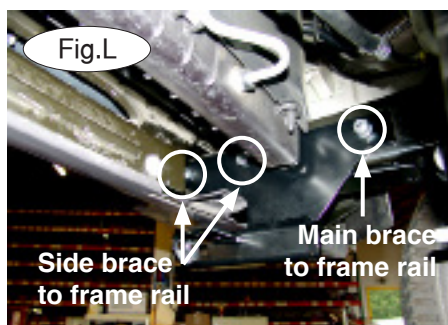

Fig.L

Side brace to frame rail

Main brace to frame rail

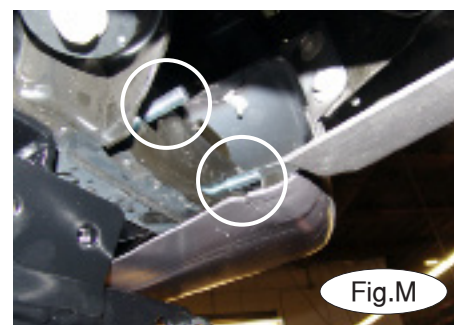

Fig.M

5. Attach one of the main braces – first, lift the front of the brace under the vehicle (Fig.J), then the rear of the brace (Fig.K). With the brace against the frame rail, align the hole at the rear of the brace over and then through the bolt you inserted into the frame rail in the previous step (Fig.K).

6. Secure the bolt in place with a $\frac{1}{2}$ " lock washer and nut (Fig.L). Finger-tighten only at this time.

7. Next, insert two $\frac{1}{2}$ " x $4\frac{1}{2}$ " bolts, lock washers and nuts through the two holes at the top of the main brace and through the two existing holes in the frame rail (Fig.L).

8. Attach the other main brace by repeating steps 4 through 7.

9. Next, attach one of the side braces to the frame rail – first, align the two pre-drilled holes at the top of the side brace over the two bolts you positioned in step 7. Fit the brace over the two bolts (Fig.M), and secure them in place with two $\frac{1}{2}$ " lock washers and nuts (Fig.N).

10. Now, bolt the side brace to the main brace, through the two pre-drilled holes at the bottom of the brace (Fig.O). Thread a $\frac{1}{2}$ " x $1\frac{1}{2}$ " bolt and lock washer through both holes in the side brace and then into the weld nuts in the main brace. Finger-tighten only at this time.

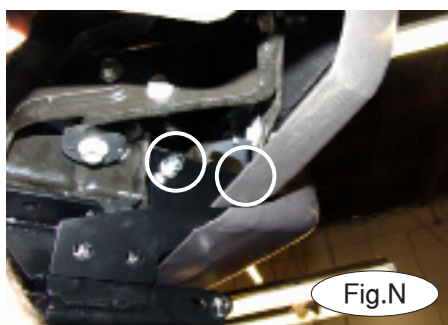

Fig.N

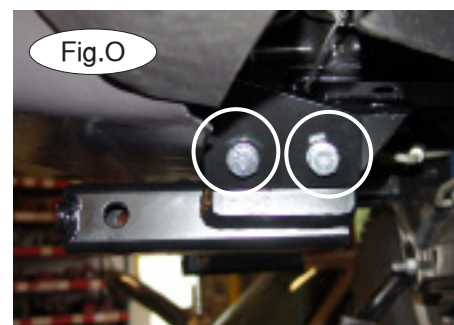

Fig.O

11. Attach the other side brace by repeating steps 9 and 10.



BASEPLATE KIT INSTALLATION INSTRUCTIONS

KIT# 2505-3

11/2025
MS

ROADMASTER, Inc.

6110 NE 127th Ave.

Vancouver, WA 98682

360-896-0407

www.RoadmasterInc.com

12. Set the cross brace across the top of the two main braces, and bolt it to the main braces with two 1/2" x 1" bolts and lock washers on each side (Fig.P). Finger-tighten only at this time.

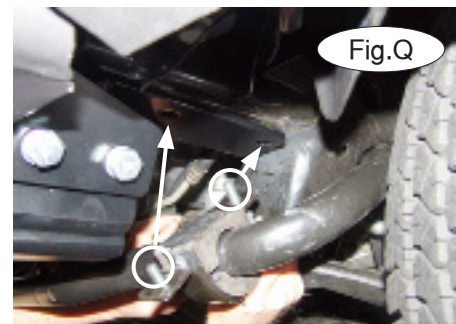
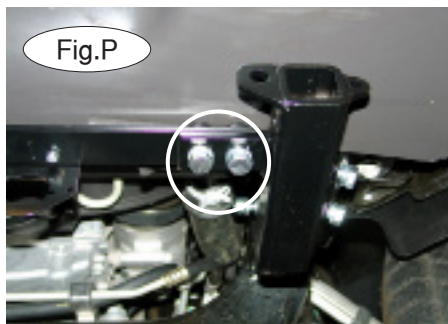

13. Reattach the sway bar mounts – bolt through the sway bar bushing mounts, the two lower holes on each main brace, and then into the frame rail, using two of the supplied 10mm x 1.5 x 40mm bolts, flat washers and lock washers on each side (Fig.Q). Finger-tighten only at this time. Figure R shows the sway bar attached on the driver side.

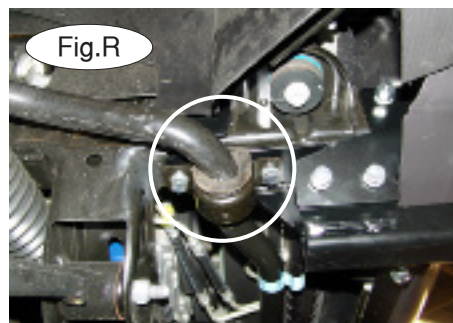

14. Check to make sure that the sway bar is aligned evenly, to both sides of the vehicle.

15. Tighten all bolts to the torque specifications at the bottom of these instructions. Start with the sway bar mount bolts, then the upper side brace bolts.

16. Reattach the rock guard and the fender liner, reversing steps 1 and 2.

Note: before reattaching the rock guard, trim an existing square opening on both sides of the rock guard to allow clearance for the main brace. Figure S shows the trimmed section on the driver side.

17. Fit the front bracket arms into the front receiver braces, and secure them in place with the supplied 5/8" draw pins and spring pins (Fig.T).

18. Install the tow bar to the mounting bracket according to the manufacturer's instructions. Attach the safety cables to the main receiver brace.

BOLT TORQUE REQUIREMENTS

Note: The torque values represented below are intended as general guidelines. Torque requirements for specific applications may vary. Roadmaster does not warrant this information to be accurate for all applications and disclaims all liability for any claims or damages which may result from its use.

STANDARD BOLTS

Thread Size	Grade	Torque
5/16.....	5.....	13 ft./lb.
3/8.....	5.....	23 ft./lb.
7/16.....	5.....	37 ft./lb.
1/2.....	5.....	56 ft./lb.
5/8.....	5.....	150 ft./lb.

METRIC BOLTS

Thread Size	Grade	Plated / Unplated
8mm-1.0.....	8.8.....	20 ft./lb. 18 ft./lb.
8mm-1.25.....	8.8.....	19 ft./lb. 18 ft./lb.
10mm-1.25.....	8.8.....	38 ft./lb. 36 ft./lb.
10mm-1.5.....	8.8.....	37 ft./lb. 35 ft./lb.

METRIC BOLTS

Thread Size	Grade	Plated / Unplated
12mm-1.25.....	8.8.....	70 ft./lb. 65 ft./lb.
12mm-1.5.....	8.8.....	66 ft./lb. 61 ft./lb.
12mm-1.75.....	8.8.....	65 ft./lb. 60 ft./lb.
14mm-2.0.....	8.8.....	104 ft./lb. 97 ft./lb.