



BASEPLATE KIT INSTALLATION INSTRUCTIONS

KIT# 267-1

04/2/19
KS

ROADMASTER, Inc. 6110 NE 127th Ave. Vancouver, WA 98682 360-896-0407 fax 360-735-9300 www.roadmasterinc.com

Important

Note: this bracket will not accommodate the Guardian rock shield, Stowaway or the StowMaster and StowMaster All Terrain tow bars.

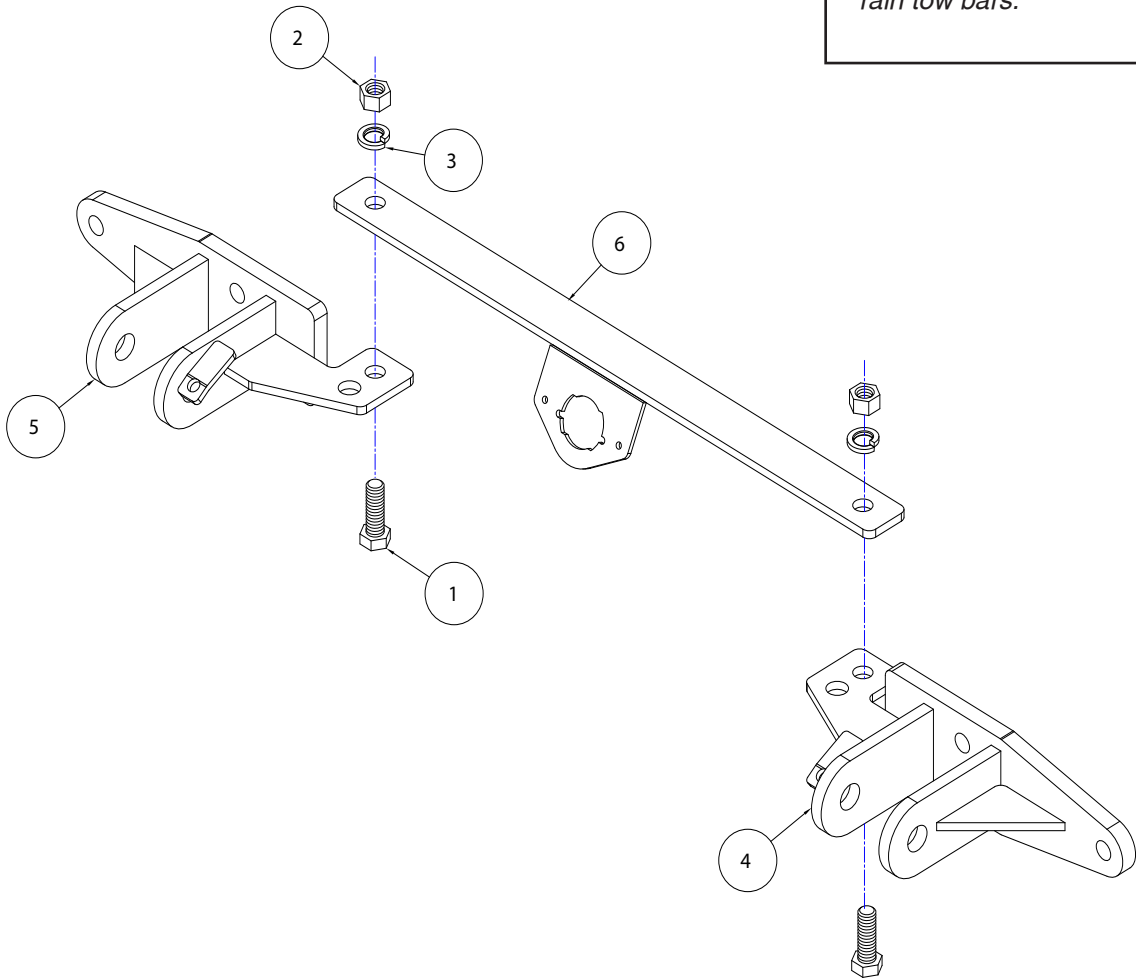

HARDWARE

ITEM	QTY	MATERIAL	NAME
1.....	2	350095-00	1/2" x 1 1/2" BOLT
2.....	2	350258-00	1/2" HEX NUT
3.....	2	350309-00	1/2" LOCK WASHER
4.....	1	C-000573	DRIVER SIDE BRACE
5.....	1	C-000574	PASSENGER SIDE BRACE
6.....	1	C-000575	CENTER BRACE

ROADMASTER, INC.



BASEPLATE KIT INSTALLATION INSTRUCTIONS

KIT# 267-1

04/2/19
KS

ROADMASTER, Inc. 6110 NE 127th Ave. Vancouver, WA 98682 360-896-0407 fax 360-735-9300 www.roadmasterinc.com

T
E
R
,
I
N
C.

1. This bracket kit is one of our MX series, which is designed to work directly with our motorhome mounted tow bars. This kit consists of a driver's side main brace, passenger side main brace, center brace and a hardware pack. The main braces mount below the front bumper fascia and grille utilizing the current front tow hook mounting points (Fig.A). Start by laying the kit out according to the illustration. This will give you a visual idea of how the kit installs and also confirm that the kit components are present and accounted for.



2. **Important:** please use all supplied bolts and parts and read all instructions carefully before beginning this installation. The majority of questions you may have can be answered within the text, and proper installation will ensure safe and secure travel. Now, begin the installation. Start by removing the front tow hook assembly (three bolts on each side) (Fig.B). Save the bolts for installing the main braces.



IMPORTANT: All baseplates **must** be assembled with all the bolts left loose for final adjustment and positioning (before tightening) unless otherwise instructed. All bolts **must** be torqued for proper strength. If more than one bolt is used per fastening point, the diagram may only show one. Use flat washers over all slotted holes and lock washers on all fasteners.

WARNING

Failure to heed these warnings or follow the installation instructions may result in a voided warranty, loss of towed vehicle, personal injury or death.

- Do not weld or modify this baseplate or its components. Welding or modification will void the warranty.
- Do not use this document as a basis to design/fabricate a baseplate, as it may not show all parts or structural components.
- We strongly recommend professional installation.
- If the towed vehicle has been in an accident, it must be properly repaired before attaching the baseplate. Do not install the baseplate if any structural frame damage is found.
- The installer must use all bolts and parts supplied. If running changes were made by the vehicle manufacturer after this kit was designed, some bolts or other fasteners may no longer be the correct size. It is the installer's responsibility to verify this kit is securely fastened to the vehicle.
- Use Loctite® Red on all bolts used to secure this baseplate. Torque all bolts to the specifications found at the end of these instructions. Do not over-torque the bolts or failure may occur.
- The installer must inspect the baseplate to ensure adequate clearance, particularly around hoses, air conditioner lines, radiators, etc. or non-warranty failure may result.
- Roadmaster manufactures many styles of baseplates. If your baseplate has removable arms, they must be removed before driving the vehicle, unless the arms can be pinned or padlocked in place. If not secured, the arms could vibrate out.
- Some motorhome chassis have such a tight turning radius that you can damage your motorhome, towed vehicle, tow bar or baseplate while turning sharply. Before getting on the road, test your turning radius in an empty parking lot. Turning too sharply could result in non-warranty damage to your towing system, motorhome and/or towed vehicle.
- Do not back up with the towed vehicle attached or non-warranty damage will occur to your towing system or vehicles.
- The safety cables must connect the towing vehicle to the towed vehicle frame to frame, with the cables crossed, with enough slack for sharp turns. See cable instructions for proper routing. Failure to do so will result in non-warranty damage and/or the loss of the towed vehicle.
- This kit is designed for use with ROADMASTER tow bars and ROADMASTER adapters only. Using this kit with other brands, without an approved ROADMASTER adapter, may result in non-warranty damage or injury.
- Receiver extensions and out-of-level towing situations of 3 inches or more. This can cause the system to swing much higher and lower, causing excessive strain on the tow bar, baseplate and frame. That can cause the towing system to fail, causing property damage, personal injury or even death. If you must use a receiver extension or drop hitch to tow, it will reduce your receiver's weight capacity by 1/3 to avoid damaging your system. Never use more than one extension and/or drop hitch, as this will void your warranty.
- Every 3,000 miles, the owner must inspect all mounting points for cracks or fatigue, and check the fasteners for proper torque, according to the bolt torque requirements chart on the last page of these instructions.
- The owner must follow the vehicle manufacturer's instructions to prepare the vehicle for towing. Failure to do so may cause severe damage to the vehicle.
- This baseplate is only warranted for the original installation. Installing a used baseplate on another vehicle is not recommended and will void the warranty.



BASEPLATE KIT INSTALLATION INSTRUCTIONS

KIT# 267-1

04/2/19
KS

ROADMASTER, Inc. 6110 NE 127th Ave. Vancouver, WA 98682 360-896-0407 fax 360-735-9300 www.roadmasterinc.com

ROADMASTER, INC.

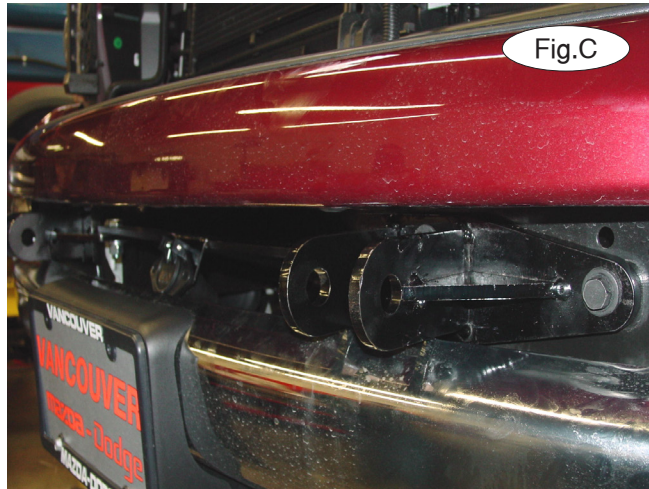

Fig.C

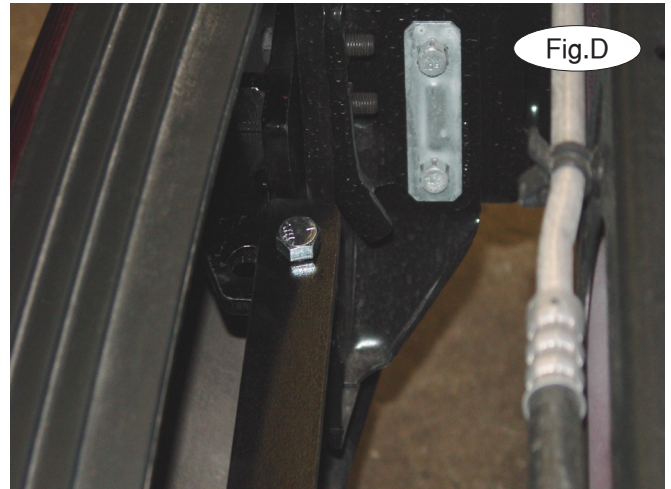

Fig.D

3. Install the main braces on each side using the stock tow hook assembly bolts removed in step 2 (Fig.C).
4. Slide the center brace on the top of the main braces over the rear inside mounting holes (Fig.D).
5. Go behind the bumper and put a $\frac{1}{2}$ " x $1\frac{1}{2}$ " bolts through each end and the main braces (Fig.D).
6. Install the nuts, lock washers and flat washers (Fig.E).
7. Torque all mounting bolts to the specifications below.
8. Mount the tow bar according to the manufacturer's instructions.
9. Connect the tow vehicle's safety cables to the holes provided just in front of the center brace on the inside of main braces. A wiring plug connector bracket has been provided on the center brace (Fig.F).

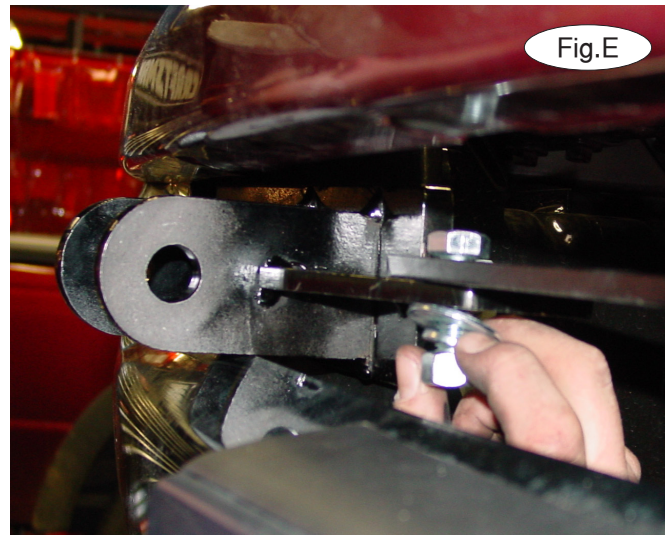

Fig.E



Fig.F



BASEPLATE KIT INSTALLATION INSTRUCTIONS

KIT# 267-1

04/2/19
KS

ROADMASTER, Inc. 6110 NE 127th Ave. Vancouver, WA 98682 360-896-0407 fax 360-735-9300 www.roadmasterinc.com

R O A D M A S T E R , I N C .

BOLT TORQUE REQUIREMENTS

Note: The torque values represented below are intended as general guidelines. Torque requirements for specific applications may vary. Roadmaster does not warrant this information to be accurate for all applications and disclaims all liability for any claims or damages which may result from its use.

STANDARD BOLTS			METRIC BOLTS			METRIC BOLTS		
Thread Size	Grade	Torque	Thread Size	Grade	Plated / Unplated	Thread Size	Grade	Plated / Unplated
5/16.....	5.....	13 ft./lb.	8mm-1.0	8.8	20 ft./lb. 18 ft./lb.	12mm-1.25	8.8	70 ft./lb. 65 ft./lb.
3/8.....	5.....	23 ft./lb.	8mm-1.25	8.8	19 ft./lb. 18 ft./lb.	12mm-1.5	8.8	66 ft./lb. 61 ft./lb.
7/16.....	5.....	37 ft./lb.	10mm-1.25	8.8	38 ft./lb. 36 ft./lb.	12mm-1.75	8.8	65 ft./lb. 60 ft./lb.
1/2.....	5.....	56 ft./lb.	10mm-1.5	8.8	37 ft./lb. 35 ft./lb.	14mm-2.0	8.8	104 ft./lb. 97 ft./lb.
5/8.....	5.....	150 ft./lb.						

All illustrations and specifications contained herein are based on the latest information available at the time of publication approval.
ROADMASTER, INC. reserves the right to make changes at any time without notice in material, specification and models or to discontinue models.