



BASEPLATE KIT INSTALLATION INSTRUCTIONS

KIT# 290-3

02/08/10
KS

ROADMASTER, Inc. 6110 NE 127th Ave. Vancouver, WA 98682 360-896-0407 fax 360-735-9300 www.roadmasterinc.com

Important
Note: this bracket will not accommodate the Guardian rock shield, some models of the Tow Defender, Stowaway or the StowMaster and StowMaster All Terrain tow bars.

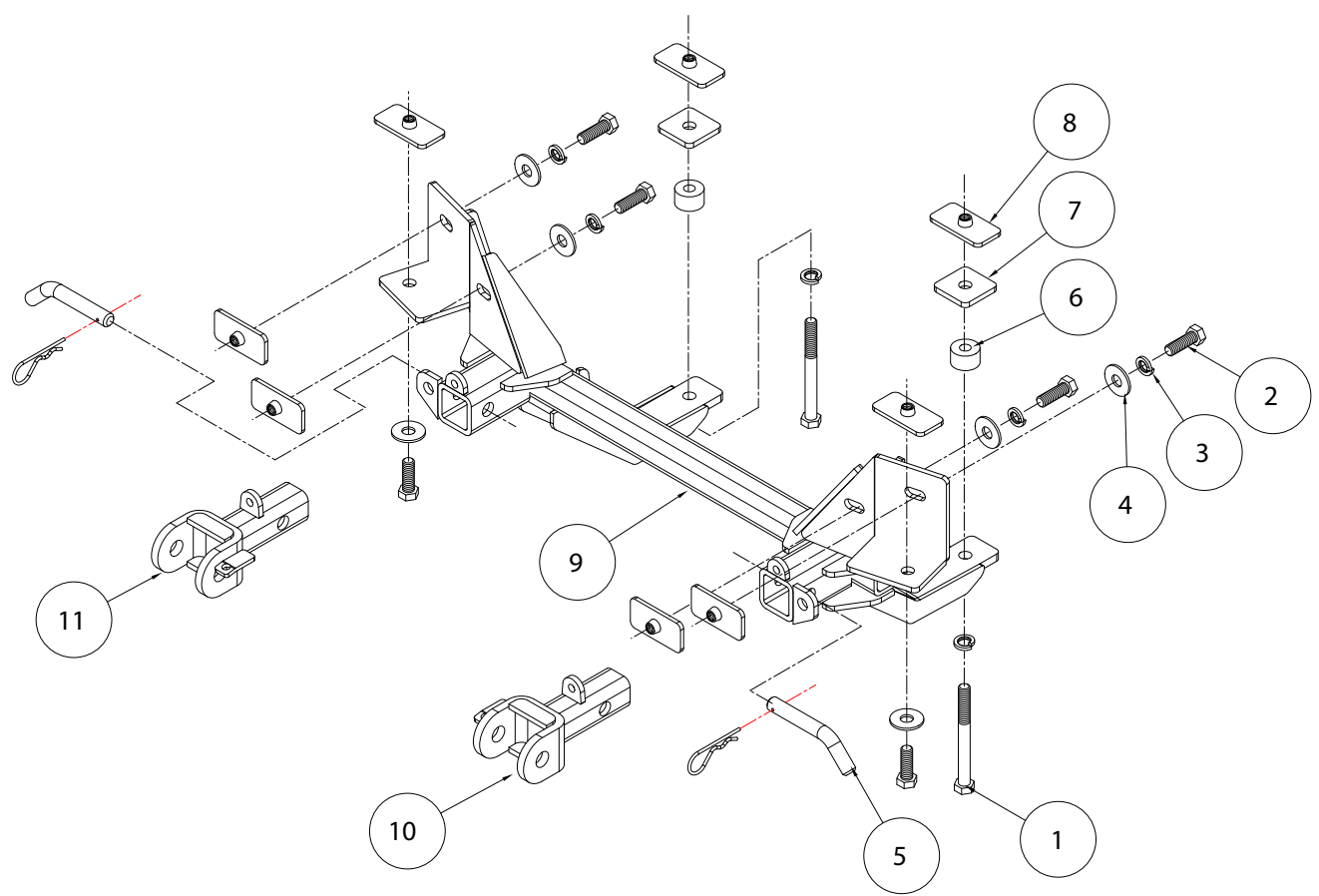

ITEM	QTY	NAME	MATERIAL
1	2	1/2" x 5" BOLT	350107-00
2	6	1/2" X 1 1/2" BOLT	350095-00
3	8	1/2" LOCK WASHER	350309-00
4	6	1/2" FLAT WASHER	350308-00
5	2	DRAW PIN W/ CLIP	357035-00
6	2	1 1/4" O.D. x 3/4"	A-000873
7	2	3/16" x 2" x 2" ROUND HOLE BACKING PLATE	A-001066
8	8	3/16" x 1 1/2" x 3" THREADED BACKING PLATE	A-003079
9	1	MAIN RECEIVER	C-001959
10	1	DRIVER SIDE ARM	C-001962
11	1	PASSENGER SIDE ARM	C-001963
12	2	RUBBER PAD	200101-00



BASEPLATE KIT INSTALLATION INSTRUCTIONS

KIT# 290-3

02/08/10
KS

ROADMASTER, Inc. 6110 NE 127th Ave. Vancouver, WA 98682 360-896-0407 fax 360-735-9300 www.roadmasterinc.com

This bracket kit is one of our XL series, which allows the visible front portion of the brackets to be easily removed (Fig.A and Fig.B). The kit consists of the main receiver brace, removable front braces, rear braces, lower braces and a hardware pack.

The main receiver brace mounts to the front frame and bumper core on each side. The removable front braces insert into the receivers on each side and are secured with draw pins.

Before starting the installation, lay out the kit components in order, as they will be used. This will give you a visual idea of how the components work, and will also confirm that everything is present and accounted for.



IMPORTANT: All baseplates **must** be assembled with all the bolts left loose for final adjustment and positioning (before tightening) unless otherwise instructed. All bolts **must** be torqued for proper strength. If more than one bolt is used per fastening point, the diagram may only show one. Use flat washers over all slotted holes and lock washers on all fasteners.

WARNING

Failure to heed these warnings or follow the installation instructions may result in a voided warranty, loss of towed vehicle, personal injury or death.

- Do not weld or modify this baseplate or its components. Welding or modification will void the warranty.
- Do not use this document as a basis to design/fabricate a baseplate, as it may not show all parts or structural components.
- We strongly recommend professional installation.
- If the towed vehicle has been in an accident, it must be properly repaired before attaching the baseplate. Do not install the baseplate if any structural frame damage is found.
- The installer must use all bolts and parts supplied. If running changes were made by the vehicle manufacturer after this kit was designed, some bolts or other fasteners may no longer be the correct size. It is the installer's responsibility to verify this kit is securely fastened to the vehicle.
- Use Loctite® Red on all bolts used to secure this baseplate. Torque all bolts to the specifications found at the end of these instructions. Do not over-torque the bolts or failure may occur.
- The installer must inspect the baseplate to ensure adequate clearance, particularly around hoses, air conditioner lines, radiators, etc. or non-warranty failure may result.
- Roadmaster manufactures many styles of baseplates. If your baseplate has removable arms, they must be removed before driving the vehicle, unless the arms can be pinned or padlocked in place. If not secured, the arms could vibrate out.
- Some motorhome chassis have such a tight turning radius that you can damage your motorhome, towed vehicle, tow bar or baseplate while turning sharply. Before getting on the road, test your turning radius in an empty parking lot. Turning too sharply could result in non-warranty damage to your towing system, motorhome and/or towed vehicle.
- Do not back up with the towed vehicle attached or non-warranty damage will occur to your towing system or vehicles.
- The safety cables must connect the towing vehicle to the towed vehicle frame to frame, with the cables crossed, with enough slack for sharp turns. See cable instructions for proper routing. Failure to do so will result in non-warranty damage and/or the loss of the towed vehicle.
- This kit is designed for use with ROADMASTER tow bars and ROADMASTER adapters only. Using this kit with other brands, without an approved ROADMASTER adapter, may result in non-warranty damage or injury.
- Receiver extensions and out-of-level towing situations of 3 inches or more. This can cause the system to swing much higher and lower, causing excessive strain on the tow bar, baseplate and frame. That can cause the towing system to fail, causing property damage, personal injury or even death. If you must use a receiver extension or drop hitch to tow, it will reduce your receiver's weight capacity by 1/3 to avoid damaging your system. Never use more than one extension and/or drop hitch, as this will void your warranty.
- Every 3,000 miles, the owner must inspect all mounting points for cracks or fatigue, and check the fasteners for proper torque, according to the bolt torque requirements chart on the last page of these instructions.
- The owner must follow the vehicle manufacturer's instructions to prepare the vehicle for towing. Failure to do so may cause severe damage to the vehicle.
- This baseplate is only warranted for the original installation. Installing a used baseplate on another vehicle is not recommended and will void the warranty.



BASEPLATE KIT INSTALLATION INSTRUCTIONS

KIT# 290-3

02/08/10
KS

ROADMASTER, Inc. 6110 NE 127th Ave. Vancouver, WA 98682 360-896-0407 fax 360-735-9300 www.roadmasterinc.com

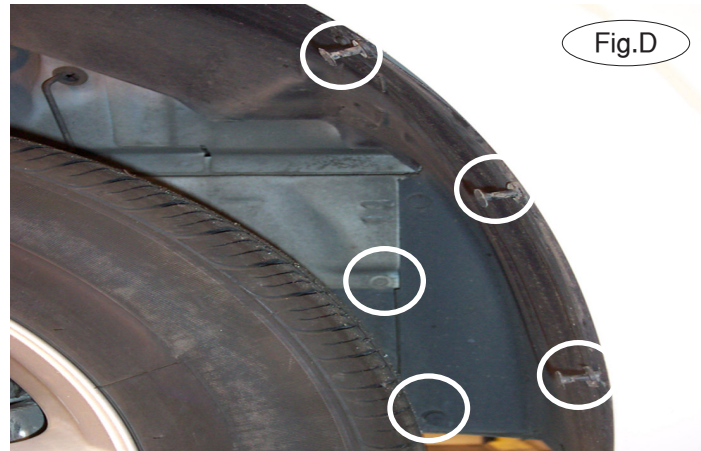

1. **Important:** please use all supplied bolts and parts and read all instructions carefully before beginning this installation. The majority of questions you may have can be answered within the text, and proper installation will ensure safe and secure travel. Now, begin the installation by removing five plastic fasteners attaching the top of the fascia to the core support (Fig.C).

2. On each side, remove four plastic fasteners (Fig.D) and one 7mm screw attaching the fender liner to the fascia (Fig.E).



3. On each side, remove one plastic fastener attaching the lower splash shield to the bottom of the fascia (Fig.F) and three across the center attaching the lower splash shield to the radiator support (Fig.G).





BASEPLATE KIT INSTALLATION INSTRUCTIONS

KIT# 290-3

02/08/10
KS

ROADMASTER, Inc. 6110 NE 127th Ave. Vancouver, WA 98682 360-896-0407 fax 360-735-9300 www.roadmasterinc.com



4. Disconnect the fog lights, if the vehicle is so equipped (Fig.H).
5. Pull out and forward on the corners of the fascia to remove it (Fig.I).

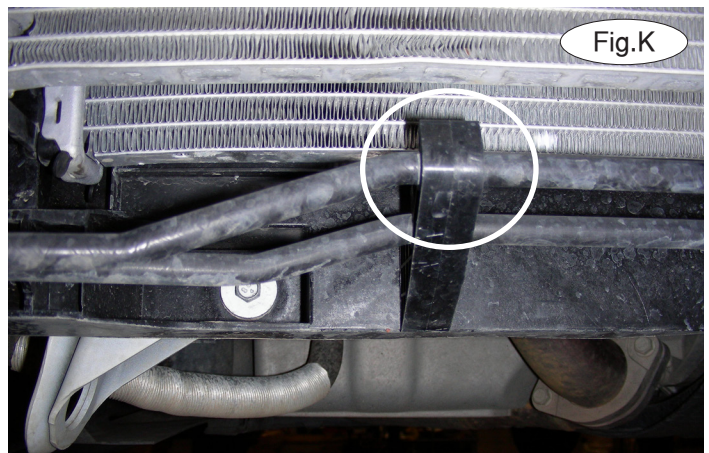
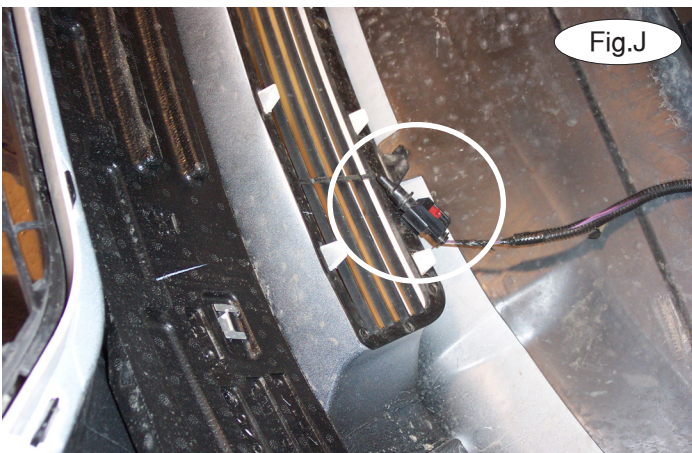

6. Disconnect the ambient temperature sensor from the back of the fascia (Fig.J).
7. Remove the left plastic hanger attaching the power steering cooler to the radiator support (Fig.K). Measure three inches to the right of the hole and drill a 1/4" hole level with the pre-existing power steering mount. Remount the plastic hanger in this hole. Figure L shows the remounted plastic hanger.

Now, trim the lower core support on the passenger side (Fig.L) and the driver's side (Fig.M) to allow clearance for the main receiver brace.

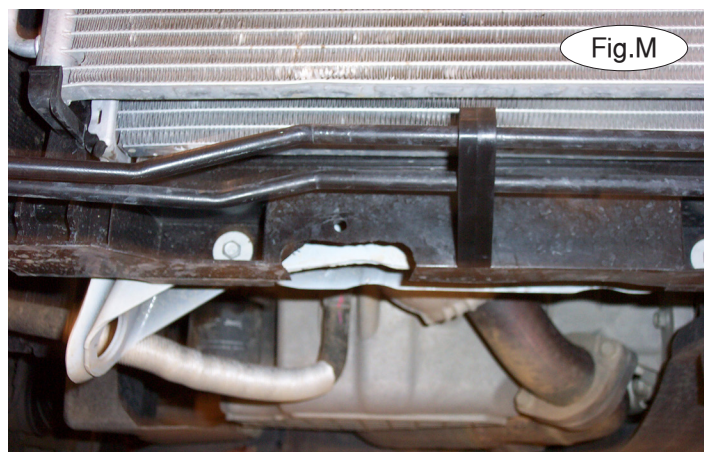
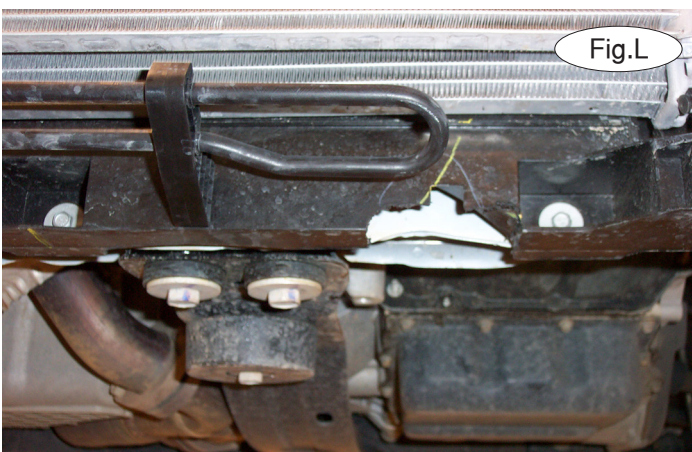



BASEPLATE KIT INSTALLATION INSTRUCTIONS

KIT# 290-3

02/08/10
KS

ROADMASTER, Inc. 6110 NE 127th Ave. Vancouver, WA 98682 360-896-0407 fax 360-735-9300 www.roadmasterinc.com



Fig.N

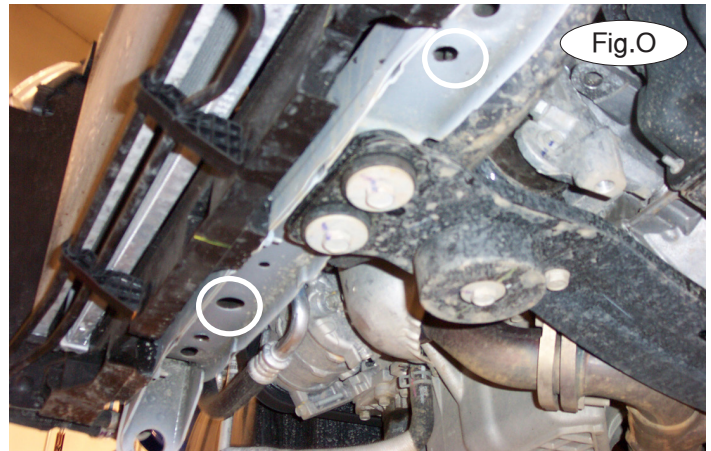

Fig.O

8. Disconnect the two plastic fasteners attaching the wiring harness to the top of the core support (Fig.N).

9. Locate the two pre-existing holes in the bottom of the core support, located behind the areas you trimmed in a previous step. Using a $\frac{1}{2}$ " drill bit, enlarge the two holes and drill through the upper layer of the bumper core (Fig.O). *Note:* use a piece of metal to avoid drilling into the engine components.



Fig.P

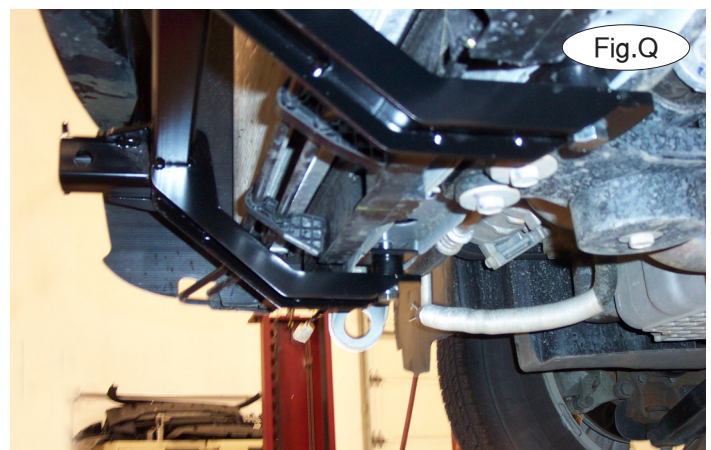

Fig.Q

10. Starting on the driver's side, place a $\frac{1}{2}$ " lock washer over a $\frac{1}{2}$ " x 5" bolt for each of the two rear mounting points. Place the bolts through the rear mounting points of the main receiver brace and place a $\frac{1}{4}$ " x $\frac{3}{4}$ " pipe spacer and a $\frac{1}{4}$ " x 2" x 2" backing plate over the bolts (Fig.P).

Bolt through the top and bottom of the radiator support and into a $\frac{1}{4}$ " x $1\frac{1}{2}$ " x 3" nipped backing plate (Fig.Q).

11. Clamp the main receiver brace to the core support (Fig.R).



Fig.R



BASEPLATE KIT INSTALLATION INSTRUCTIONS

KIT# 290-3

02/08/10
KS

ROADMASTER, Inc. 6110 NE 127th Ave. Vancouver, WA 98682 360-896-0407 fax 360-735-9300 www.roadmasterinc.com

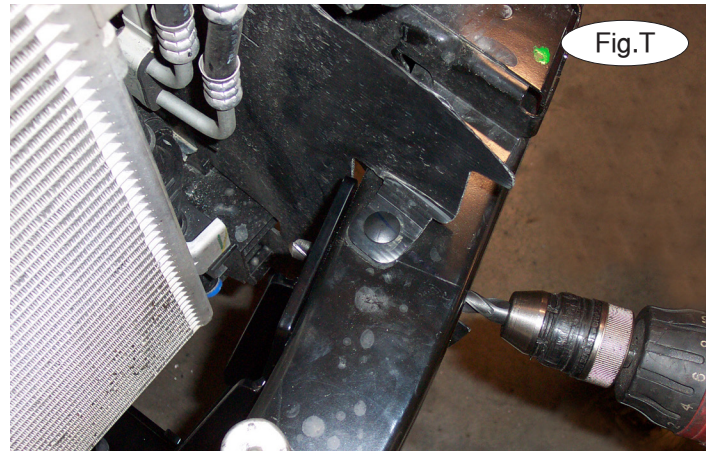
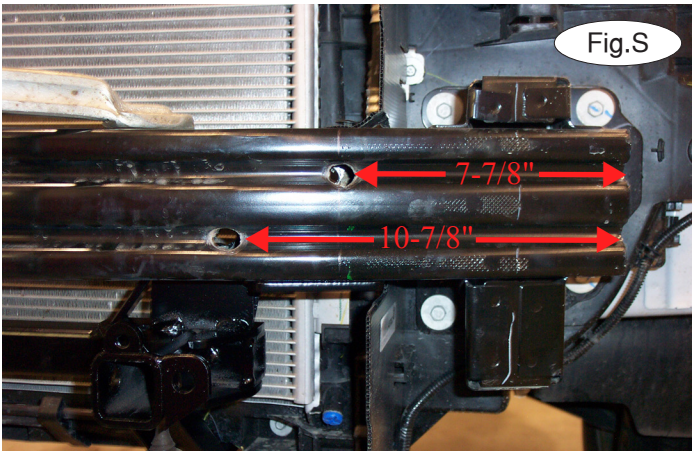

12. Working on the driver's side, from the edge of the top groove on the bumper core, measure over 7-7/8" and drill a 1/2" access hole. From the edge of the bottom groove, measure 10-7/8" and drill another 1/2" access hole (Fig.T). These holes will allow the installer access from the rear of the bumper core.

13. Holding the drill level with the front of the bumper core, place the drill through each access hole and drill a 1/2" hole through the bumper core and the pre-existing hole in the main receiver brace (Fig.T).



14. Place two of the 3/16" x 1 1/2" x 3" threaded backing plates in the end of the bumper core (Fig.U). Now, using two of the supplied 1/2" x 1 1/2" bolts, 1/2" flat washer and lock washer, bolt through the main receiver brace, bumper core and into the threaded backing plate (Fig.V).

15. Repeat steps 12 through 14 for the passenger side.

16. Tighten all bolts to the bolt torque requirements found at the end of these instructions.

17. Remove the clamps.

18. Working on the driver's side, use the end mounting point of the main receiver brace as a template and drill up through the bottom of the bumper core (Fig.W).

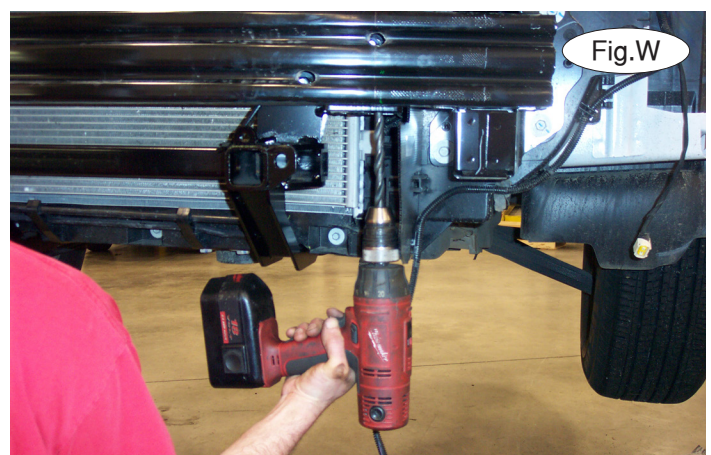



BASEPLATE KIT INSTALLATION INSTRUCTIONS

KIT# 290-3

02/08/10
KS

ROADMASTER, Inc. 6110 NE 127th Ave. Vancouver, WA 98682 360-896-0407 fax 360-735-9300 www.roadmasterinc.com

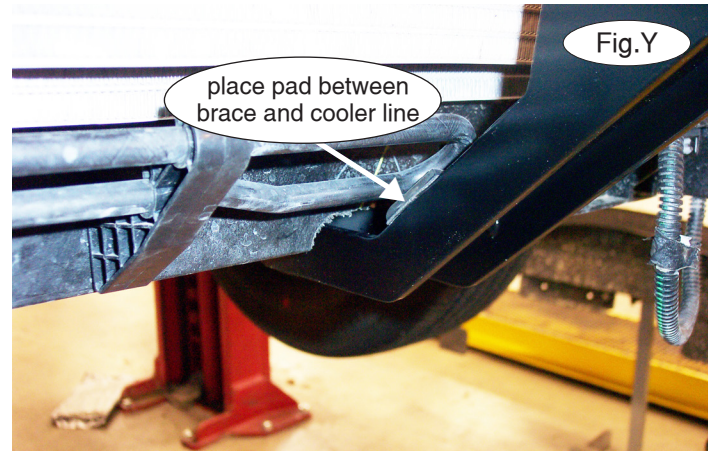

19. Place one of the 3/16" x 1 1/2" x 3" threaded backing plates in the end of the bumper core. Using one of the supplied 1/2" x 1 1/2" bolts and a 1/2" lock washer, bolt up through the main receiver brace and bumper core, and into the threaded backing plate (Fig.X).

20. Repeat steps 18 and 19 for the passenger side. Torque all bolts to the bolt torque requirements found at the end of this document.



21. On each side, place one of the adhesive rubber pads between the lower support of the main receiver brace and the power steering cooler line (Fig.Y).

22. Trim the fascia by removing the first three horizontal ribs on each side (Fig.Z – driver's side).

23. Trim the lower splash shield using the red lines in Figure AA as a guide for trimming.

24. Reassemble the fascia, reversing steps 1 through 6.

25. Insert the removable front bracket arms into the front receiver braces, and secure them in place with the supplied 5/8" draw pins and spring pins.

26. Attach the 8" safety cables with the cable connectors (Q-Links) to the front of the receiver braces.

27. Attach the ends of the safety cables to the main receiver brace.



BASEPLATE KIT INSTALLATION INSTRUCTIONS

KIT# 290-3

02/08/10
KS

ROADMASTER, Inc. 6110 NE 127th Ave. Vancouver, WA 98682 360-896-0407 fax 360-735-9300 www.roadmasterinc.com

BOLT TORQUE REQUIREMENTS

Note: The torque values represented below are intended as general guidelines. Torque requirements for specific applications may vary. Roadmaster does not warrant this information to be accurate for all applications and disclaims all liability for any claims or damages which may result from its use.

STANDARD BOLTS

Thread Size	Grade	Torque
5/16.....	5.....	13 ft./lb.
3/8.....	5.....	23 ft./lb.
7/16.....	5.....	37 ft./lb.
1/2.....	5.....	56 ft./lb.
5/8.....	5.....	150 ft./lb.

METRIC BOLTS

Thread Size	Grade	Plated / Unplated
8mm-1.0.....	8.8.....	20 ft./lb. 18 ft./lb.
8mm-1.25.....	8.8.....	19 ft./lb. 18 ft./lb.
10mm-1.25.....	8.8.....	38 ft./lb. 36 ft./lb.
10mm-1.5.....	8.8.....	37 ft./lb. 35 ft./lb.

METRIC BOLTS

Thread Size	Grade	Plated / Unplated
12mm-1.25.....	8.8.....	70 ft./lb. 65 ft./lb.
12mm-1.5.....	8.8.....	66 ft./lb. 61 ft./lb.
12mm-1.75.....	8.8.....	65 ft./lb. 60 ft./lb.
14mm-2.0.....	8.8.....	104 ft./lb. 97 ft./lb.

All illustrations and specifications contained herein are based on the latest information available at the time of publication approval. ROADMASTER, INC. reserves the right to make changes at any time without notice in material, specification and models or to discontinue models.