



BASEPLATE KIT INSTALLATION INSTRUCTIONS

KIT# 3125-3

07/19/12
KS

ROADMASTER, Inc. 6110 NE 127th Ave. Vancouver, WA 98682 360-896-0407 fax 360-735-9300 www.roadmasterinc.com

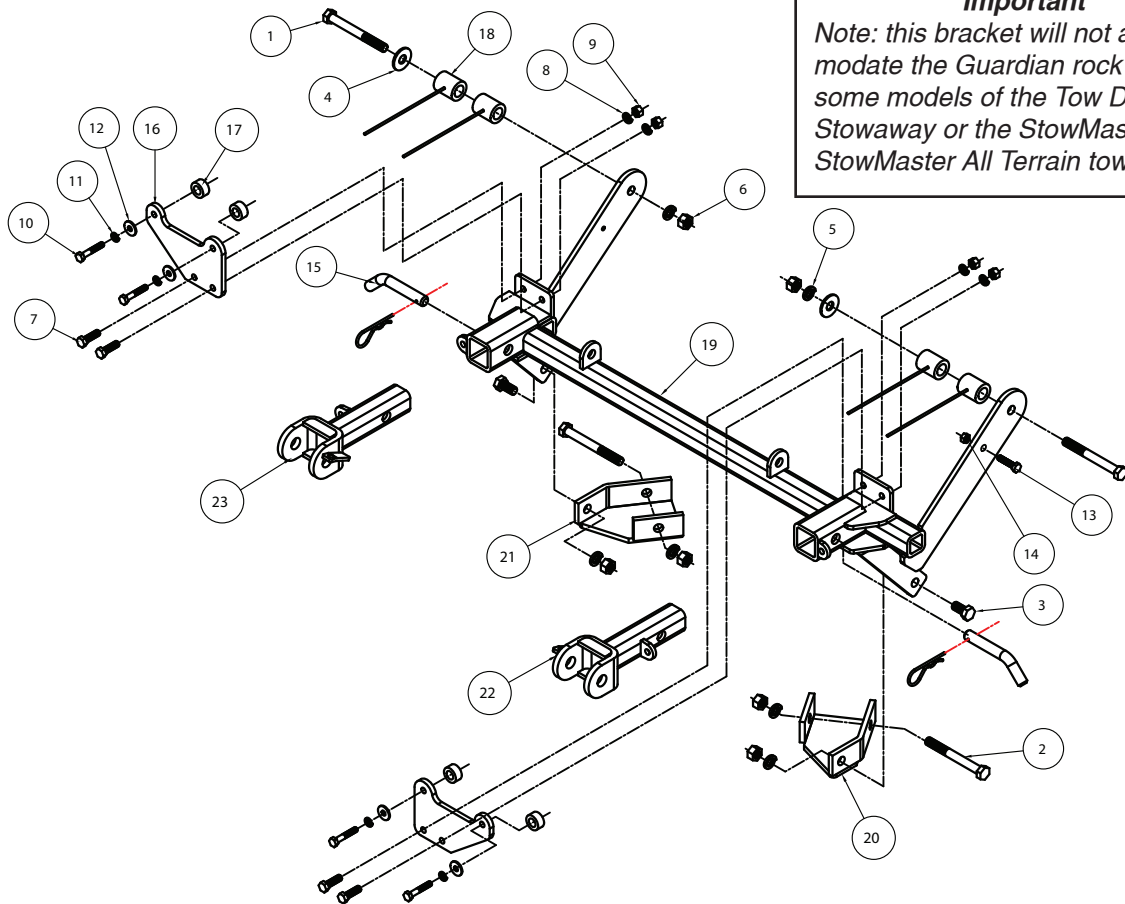

Important
Note: this bracket will not accommodate the Guardian rock shield, some models of the Tow Defender, Stowaway or the StowMaster and StowMaster All Terrain tow bars.

ITEM	QTY	NAME	MATERIAL
1.....	2	1/2" x 4 1/2" BOLT.....	350106-00
2.....	2	1/2" x 5" BOLT.....	350107-00
3.....	2	1/2" x 1 1/2" BOLT.....	350095-00
4.....	2	1/2" FLAT WASHER.....	350308-20
5.....	6	1/2" LOCK WASHER	350309-00
6.....	6	1/2" NUT.....	350258-00
7.....	4	3/8" x 1 1/4" BOLT.....	350056-00
8.....	4	3/8" LOCK WASHER	350305-00
9.....	4	3/8" NUT.....	350254-00
10.....	4	8mm x 1.25 x 55mm BOLT	356006-00
11.....	4	8mm LOCK WASHER.....	355705-00
12.....	4	8mm FENDER WASHER.....	355702-00
13.....	1	6mm x 1.0 x 35mm BOLT	355896-00
14.....	1	6mm x 1.0 NY-LOCK NUT	355760-00
15.....	2	DRAW PIN/SPRING PIN	357035-00
16.....	2	UPPER MOUNTING PLATE	A-001576
17.....	4	1" O.D. x 0.219 WALL x 3/4" PIPE SPACER	A-002063
18.....	4	1 1/4" O.D. x 0.25 WALL x 1 7/16" PIPE SPACER W/ ROD.....	C-000946
19.....	1	MAIN RECEIVER.....	C-000923
20.....	1	DRIVER SIDE FRAME CUP	C-000928
21.....	1	PASSENGER SIDE FRAME CUP	C-000929
22.....	1	DRIVER SIDE ARM	C-000926
23.....	1	PASSENGER SIDE ARM	C-000927



BASEPLATE KIT INSTALLATION INSTRUCTIONS

KIT# 3125-3

07/19/12
KS

ROADMASTER, Inc. 6110 NE 127th Ave. Vancouver, WA 98682 360-896-0407 fax 360-735-9300 www.roadmasterinc.com

This bracket kit is one of our MX series brackets with removable front braces. Everything but the front arm braces installs behind the bumper fascia, as shown in Fig. A. To begin the installation, you must first remove the fascia and lower splash panel.



IMPORTANT: All baseplates **must** be assembled with all the bolts left loose for final adjustment and positioning (before tightening) unless otherwise instructed. All bolts **must** be torqued for proper strength. If more than one bolt is used per fastening point, the diagram may only show one. Use flat washers over all slotted holes and lock washers on all fasteners.

WARNING

Failure to heed these warnings or follow the installation instructions may result in a voided warranty, loss of towed vehicle, personal injury or death.

- Do not weld or modify this baseplate or its components. Welding or modification will void the warranty.
- Do not use this document as a basis to design/fabricate a baseplate, as it may not show all parts or structural components.
- We strongly recommend professional installation.
- If the towed vehicle has been in an accident, it must be properly repaired before attaching the baseplate. Do not install the baseplate if any structural frame damage is found.
- The installer must use all bolts and parts supplied. If running changes were made by the vehicle manufacturer after this kit was designed, some bolts or other fasteners may no longer be the correct size. It is the installer's responsibility to verify this kit is securely fastened to the vehicle.
- Use Loctite® Red on all bolts used to secure this baseplate. Torque all bolts to the specifications found at the end of these instructions. Do not over-torque the bolts or failure may occur.
- The installer must inspect the baseplate to ensure adequate clearance, particularly around hoses, air conditioner lines, radiators, etc. or non-warranty failure may result.
- Roadmaster manufactures many styles of baseplates. If your baseplate has removable arms, they must be removed before driving the vehicle, unless the arms can be pinned or padlocked in place. If not secured, the arms could vibrate out.
- Some motorhome chassis have such a tight turning radius that you can damage your motorhome, towed vehicle, tow bar or baseplate while turning sharply. Before getting on the road, test your turning radius in an empty parking lot. Turning too sharply could result in non-warranty damage to your towing system, motorhome and/or towed vehicle.
- Do not back up with the towed vehicle attached or non-warranty damage will occur to your towing system or vehicles.
- The safety cables must connect the towing vehicle to the towed vehicle frame to frame, with the cables crossed, with enough slack for sharp turns. See cable instructions for proper routing. Failure to do so will result in non-warranty damage and/or the loss of the towed vehicle.
- This kit is designed for use with ROADMASTER tow bars and ROADMASTER adapters only. Using this kit with other brands, without an approved ROADMASTER adapter, may result in non-warranty damage or injury.
- Receiver extensions and out-of-level towing situations of 3 inches or more. This can cause the system to swing much higher and lower, causing excessive strain on the tow bar, baseplate and frame. That can cause the towing system to fail, causing property damage, personal injury or even death. If you must use a receiver extension or drop hitch to tow, it will reduce your receiver's weight capacity by 1/3 to avoid damaging your system. Never use more than one extension and/or drop hitch, as this will void your warranty.
- Every 3,000 miles, the owner must inspect all mounting points for cracks or fatigue, and check the fasteners for proper torque, according to the bolt torque requirements chart on the last page of these instructions.
- The owner must follow the vehicle manufacturer's instructions to prepare the vehicle for towing. Failure to do so may cause severe damage to the vehicle.
- This baseplate is only warranted for the original installation. Installing a used baseplate on another vehicle is not recommended and will void the warranty.



BASEPLATE KIT INSTALLATION INSTRUCTIONS

KIT# 3125-3

07/19/12
KS

ROADMASTER, Inc. 6110 NE 127th Ave. Vancouver, WA 98682 360-896-0407 fax 360-735-9300 www.roadmasterinc.com

1. **Important:** please use all supplied bolts and parts and read all instructions carefully before beginning this installation. The majority of questions you may have can be answered within the text, and proper installation will ensure safe and secure travel. Now, begin the installation. On both sides, remove one 10mm (head) screw and four plastic fasteners attaching the fascia to the wheel wells.
2. Remove 20 plastic fasteners attaching the fascia to the splash panel, and 8 attaching the top of the grill to the fascia.
3. Now, disconnect the head light cleaner feed hose from the windshield washer reservoir, and plug the holes to prevent leakage. Remove four bolts and one nut from the washer reservoir, and set the bottle aside for now.

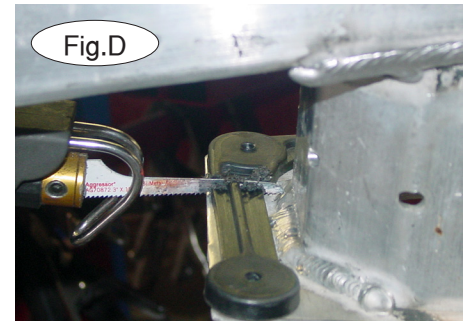
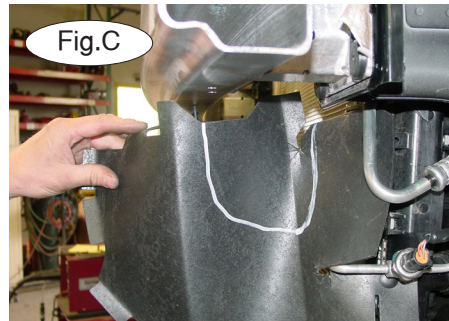
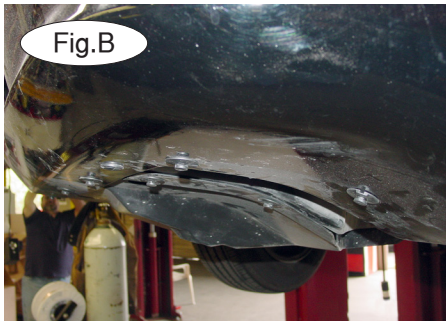

4. Remove the horn assembly. Now, disconnect the fog lamp terminals and pull forward on the fascia to remove it.
5. If the car is equipped with a power steering cooler, remove the two 10mm (head) bolts attaching it to the bumper core. One bolt is located on top of the bumper core and the other is on the back of it.
6. Now, disconnect the rubber splash panel from the bottom of the bumper (Fig.B). The splash shield will need to be trimmed before it is reinstalled in a later step. Use the white lines in Figure C as a guide for trimming.

7. Remove the 13mm (head) nuts and studs attaching the bumper to the end of the frame horns (Fig. D). *Note:* if the vehicle is so equipped, tow package auxiliary fans must be removed and will not be replaced. Retain the fans and attachment hardware in case the bracket is ever removed.

8. Place the four supplied pipe spacers with handles into the ends of the frame tubes (Fig. E). Position the receiver brace so the upper rear mounting plate holes line up with the existing holes in the frame. *Note:* these holes may need to be enlarged to 1/2".

9. The driver side mounting plate must be on the outside of the frame rail, and the passenger side must be to the inside of the frame rail. Use a 1/2" x 4 1/2" bolt and 1/2" flat washers and nuts to secure the mounting plates. The washers must be on the frame wall, not the mounting plate, as shown in Figure F.

10. Tighten all bolts to the torque specifications found at the end of these instructions.

11. Clip the ends of the spacer handles so they are flush with the end of frame tube, and reattach the bumper core using the upper studs only.

12. On the driver side of the receiver brace, there is a hole on the upper rear mounting plate. Use this hole to mount the horn bracket removed in step 2. Use the supplied 6mm x 1.0 x 35mm bolt and lock nut. Reattach the windshield washer reservoir by reversing step 3.

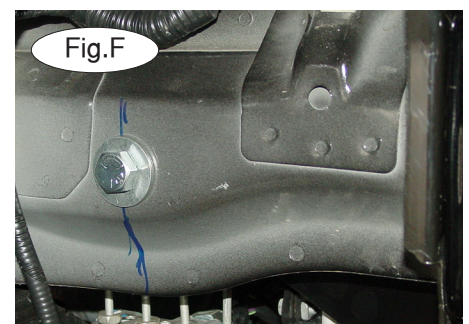
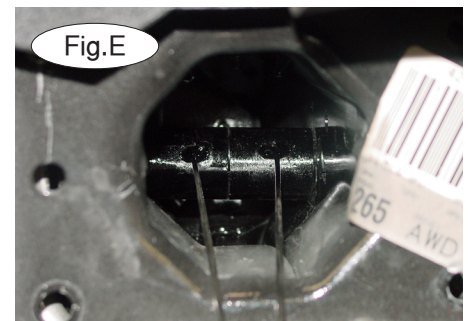



BASEPLATE KIT INSTALLATION INSTRUCTIONS

KIT# 3125-3

07/19/12
KS

ROADMASTER, Inc. 6110 NE 127th Ave. Vancouver, WA 98682 360-896-0407 fax 360-735-9300 www.roadmasterinc.com

- 13. You will now need to attach the receiver brace to the bumper core using the two upper mounting plates. The mounting plates should be positioned in front of the lower holes on the bumper core mounting bracket, separated by 1" x 3/4" pipe spacers. Bolt through the mounting plate with 8mm x 1.25 x 55mm bolts, lock washers and fender washers, then use the shoulder nuts from the original studs on the back side to fasten together.
- 14. Align the two lower holes in the mounting plate with the upper mounting tabs on the receiver brace. The mounting plate will bolt in front of the tabs on the receiver brace with 3/8" x 1 1/4" bolts, lock washers and nuts (Fig G).
- 15. Once the main brace is bolted in place, zip tie the power steering cooling lines to the rear of the main brace (Fig H).
- 16. Once the upper mounting points of the receiver brace are secure, bolt the lower rear mounting plates to the frame brackets that cup the lower portion of the subframe with a 1/2" x 1 1/2" bolt, lock washer and nut on each side.

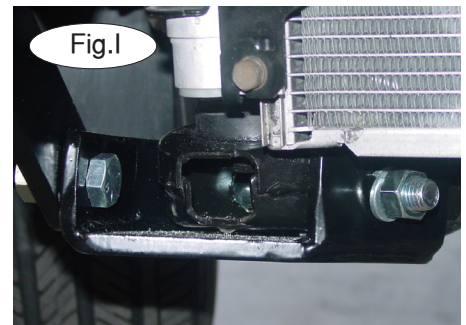
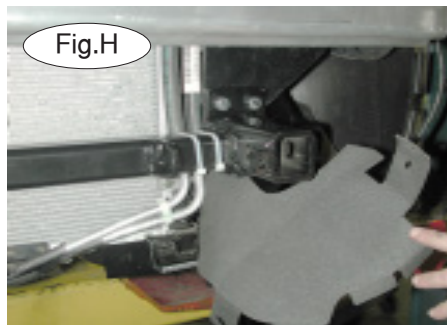
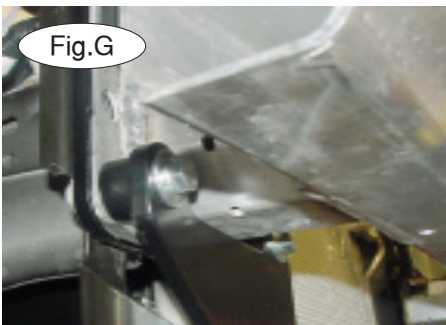

- 17. Using the pre-drilled holes in the main receiver brace as templates, drill through the frame brackets and into the subframe with a 17/32" drill bit. Then, bolt through the the brackets with 1/2" x 5" bolts, lock washers and nuts (Fig. I).
- 18. Tighten all bolts to the torque specifications below.
- 19. Reinstall the bumper fascia by reversing steps 1 through 6.
- 20. Insert the front arms into the receiver tubes and secure with the supplied draw pins and spring pins. Mount the tow bar according to the manufacturer's instructions.
- 21. Attach one end of the 12" safety cables to the tabs provided on the center tube of the main receiver brace.
- 22. Attach the safety cables to the main receiver brace.

BOLT TORQUE REQUIREMENTS

Note: The torque values represented below are intended as general guidelines. Torque requirements for specific applications may vary. Roadmaster does not warrant this information to be accurate for all applications and disclaims all liability for any claims or damages which may result from its use.

STANDARD BOLTS

Thread Size	Grade	Torque
5/16.....	5.....	13 ft./lb.
3/8.....	5.....	23 ft./lb.
7/16.....	5.....	37 ft./lb.
1/2.....	5.....	56 ft./lb.
5/8.....	5.....	150 ft./lb.

METRIC BOLTS

Thread Size	Grade	Plated / Unplated
8mm-1.0.....	8.8.....	20 ft./lb. 18 ft./lb.
8mm-1.25.....	8.8.....	19 ft./lb. 18 ft./lb.
10mm-1.25.....	8.8.....	38 ft./lb. 36 ft./lb.
10mm-1.5.....	8.8.....	37 ft./lb. 35 ft./lb.

METRIC BOLTS

Thread Size	Grade	Plated / Unplated
12mm-1.25.....	8.8.....	70 ft./lb. 65 ft./lb.
12mm-1.5.....	8.8.....	66 ft./lb. 61 ft./lb.
12mm-1.75.....	8.8.....	65 ft./lb. 60 ft./lb.
14mm-2.0.....	8.8.....	104 ft./lb. 97 ft./lb.

All illustrations and specifications contained herein are based on the latest information available at the time of publication approval. ROADMASTER, INC. reserves the right to make changes at any time without notice in material, specification and models or to discontinue models.