



BASEPLATE KIT INSTALLATION INSTRUCTIONS

KIT# 3128-3

04/15/14
KS

ROADMASTER, Inc. 6110 NE 127th Ave. Vancouver, WA 98682 360-896-0407 fax 360-735-9300 www.roadmasterinc.com

Important

Note: this bracket will not accommodate the Guardian rock shield, some models of the Tow Defender, Stowaway or the StowMaster and StowMaster All Terrain tow bars.

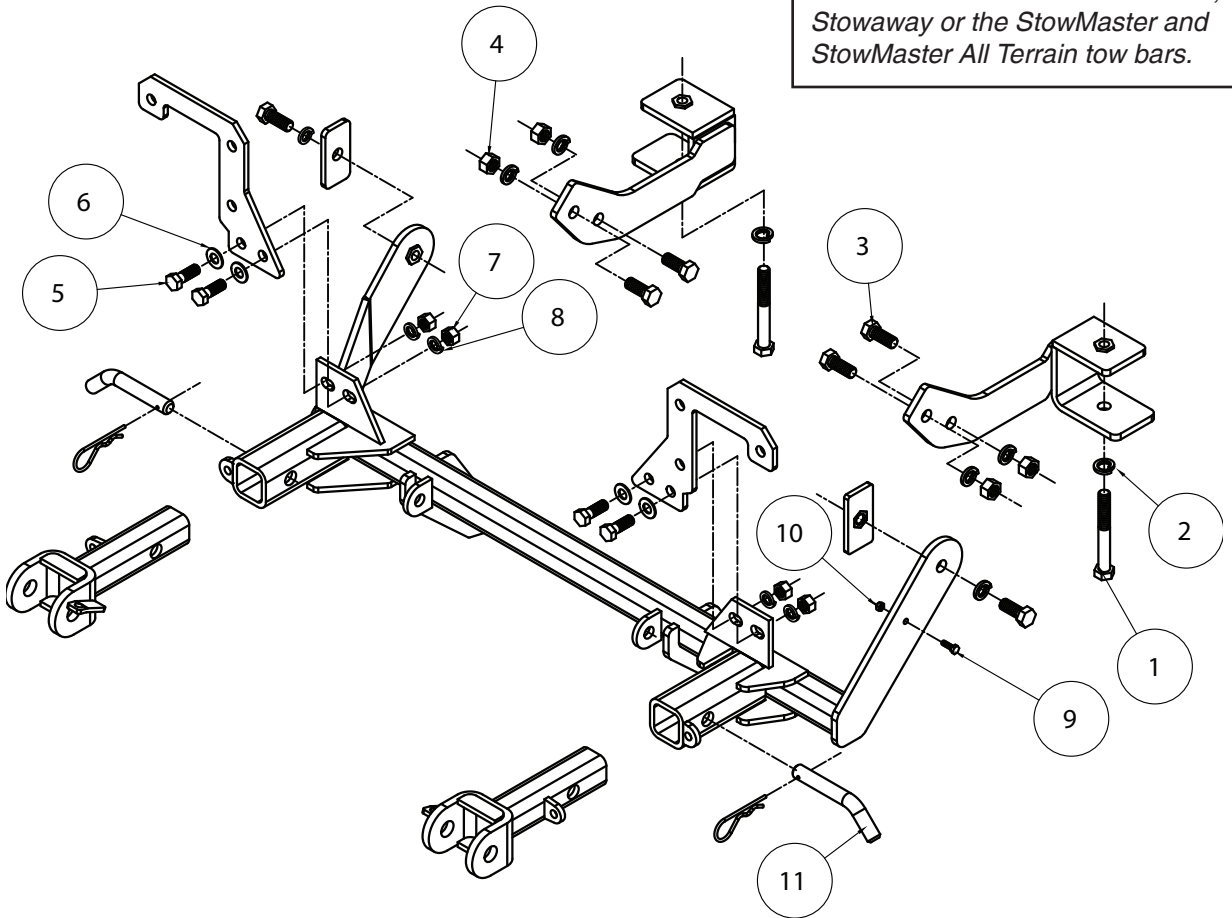

Item	Qty.	Length	Width	Description	Part #
1	2	4"	1/2"	1/2" X 4" BOLT	350105-00
2	8		1/2"	LOCK WASHER	350309-00
3	6	1 1/4"	1/2"	1/2" X 1 1/4" BOLT	350094-00
4	4		1/2"	NUT	350258-00
5	4	1 1/4"	7/16"	7/16" X 1 1/4" BOLT	350074-00
6	4		7/16"	FLAT WASHER	350345-00
7	4		7/16"	NUT	350256-00
8	4		7/16"	LOCK WASHER	350307-00
9	1	1.0	6mm	6mm X 1.0 X 25mm BOLT	355894-00
10	1		6mm	6mm NUT	355760-00
11	2			DRAW PIN/SPRING PIN	357035-00

ROADMASTER, INC.



BASEPLATE KIT INSTALLATION INSTRUCTIONS

KIT# 3128-3

04/15/14
KS

ROADMASTER, Inc. 6110 NE 127th Ave. Vancouver, WA 98682 360-896-0407 fax 360-735-9300 www.roadmasterinc.com

Item	Qty.	Part #	Description
1.....	1.....	C-001019.....	MAIN RECEIVER BRACE WELDMENT
2.....	1.....	C-001024.....	DRIVER SIDE REAR BRACE WELDMENT
3.....	1.....	C-001025.....	PASSENGER SIDE REAR BRACE WELDMENT
4.....	1.....	A-000185.....	1/4" X 1 1/2" X 3" BACKING PLATE
5.....	1.....	C-001170.....	1/4" x 1 1/2" x 3" THREADED BACKING PLATE
6.....	2.....	A-001673.....	UPPER MOUNTING PLATE
7.....	1.....	C-001022.....	DRIVER SIDE ARM BRACE WELDMENT
8.....	1.....	C-001023.....	PASSENGER SIDE ARM BRACE WELDMENT

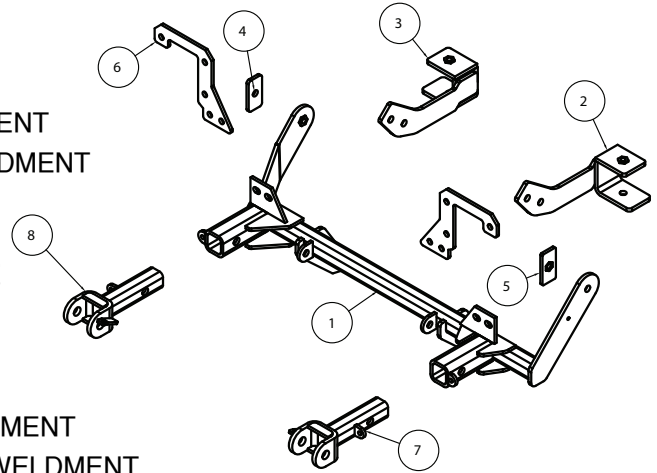

IMPORTANT: All baseplates **must** be assembled with all the bolts left loose for final adjustment and positioning (before tightening) unless otherwise instructed. All bolts **must** be torqued for proper strength. If more than one bolt is used per fastening point, the diagram may only show one. Use flat washers over all slotted holes and lock washers on all fasteners.

WARNING

Failure to heed these warnings or follow the installation instructions may result in a voided warranty, loss of towed vehicle, personal injury or death.

- Do not weld or modify this baseplate or its components. Welding or modification will void the warranty.
- Do not use this document as a basis to design/fabricate a baseplate, as it may not show all parts or structural components.
- We strongly recommend professional installation.
- If the towed vehicle has been in an accident, it must be properly repaired before attaching the baseplate. Do not install the baseplate if any structural frame damage is found.
- The installer must use all bolts and parts supplied. If running changes were made by the vehicle manufacturer after this kit was designed, some bolts or other fasteners may no longer be the correct size. It is the installer's responsibility to verify this kit is securely fastened to the vehicle.
- Use Loctite® Red on all bolts used to secure this baseplate. Torque all bolts to the specifications found at the end of these instructions. Do not over-torque the bolts or failure may occur.
- The installer must inspect the baseplate to ensure adequate clearance, particularly around hoses, air conditioner lines, radiators, etc. or non-warranty failure may result.
- Roadmaster manufactures many styles of baseplates. If your baseplate has removable arms, they must be removed before driving the vehicle, unless the arms can be pinned or padlocked in place. If not secured, the arms could vibrate out.
- Some motorhome chassis have such a tight turning radius that you can damage your motorhome, towed vehicle, tow bar or baseplate while turning sharply. Before getting on the road, test your turning radius in an empty parking lot. Turning too sharply could

result in non-warranty damage to your towing system, motorhome and/or towed vehicle.

- Do not back up with the towed vehicle attached or non-warranty damage will occur to your towing system or vehicles.
- The safety cables must connect the towing vehicle to the towed vehicle frame to frame, with the cables crossed, with enough slack for sharp turns. See cable instructions for proper routing. Failure to do so will result in non-warranty damage and/or the loss of the towed vehicle.
- This kit is designed for use with ROADMASTER tow bars and ROADMASTER adapters only. Using this kit with other brands, without an approved ROADMASTER adapter, may result in non-warranty damage or injury.
- Receiver extensions and out-of-level towing situations of 3 inches or more. This can cause the system to swing much higher and lower, causing excessive strain on the tow bar, baseplate and frame. That can cause the towing system to fail, causing property damage, personal injury or even death. If you must use a receiver extension or drop hitch to tow, it will reduce your receiver's weight capacity by 1/3 to avoid damaging your system. Never use more than one extension and/or drop hitch, as this will void your warranty.
- Every 3,000 miles, the owner must inspect all mounting points for cracks or fatigue, and check the fasteners for proper torque, according to the bolt torque requirements chart on the last page of these instructions.
- The owner must follow the vehicle manufacturer's instructions to prepare the vehicle for towing. Failure to do so may cause severe damage to the vehicle.
- This baseplate is only warranted for the original installation. Installing a used baseplate on another vehicle is not recommended and will void the warranty.



BASEPLATE KIT INSTALLATION INSTRUCTIONS

KIT# 3128-3

04/15/14
KS

ROADMASTER, Inc. 6110 NE 127th Ave. Vancouver, WA 98682 360-896-0407 fax 360-735-9300 www.roadmasterinc.com

This is one of our MX series brackets, which allows the visible front portion of the brackets to be easily removed from the front of the vehicle (Fig.A and Fig.B). The bracket consists of a main receiver brace, two lower braces, two upper braces, two removable front braces and a hardware pack.

Before starting the installation, lay out the kit components in order, as they will be used. This will give you a visual idea of how the components work, and will also confirm that everything is present and accounted for.

1. **Important:** please use all supplied bolts and parts and read all instructions carefully before beginning this installation. The majority of questions you may have can be answered within the text, and proper installation will ensure safe and secure travel. Now, begin the installation. Start by removing 10 plastic fasteners across the top of the grill and the fascia (Fig.C).

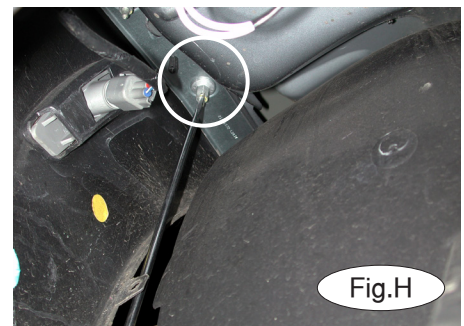
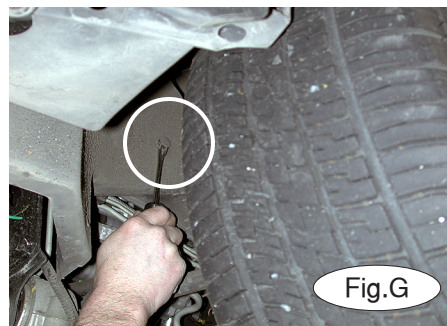
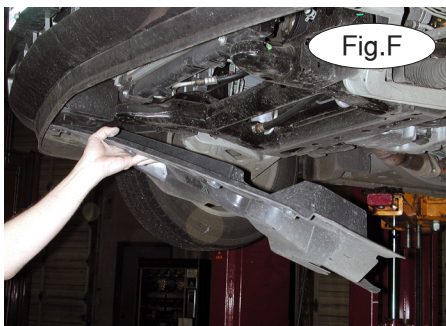
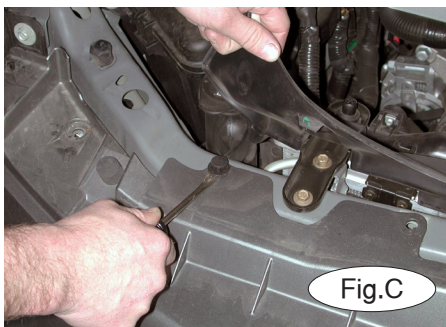

2. Then, remove three plastic fasteners along the edge of each fender well (Fig.D).

3. Remove 18 plastic fasteners attaching the center splash shield to the fascia, fender liners and the subframe (Fig.E). Then, remove the center splash shield (Fig.F).

4. Remove one plastic fastener (on each side) holding the fender liner to the frame rail (Fig.G).

5. On each side, remove two 10mm nuts and one 10mm bolt holding the fascia to the fender (Fig.H).

6. Also on each side, disconnect the plug for the side marker light, as well as the plug for the fog light and the turn signal light (Fig.I).

7. Pull down and forward on each side to remove the fascia.

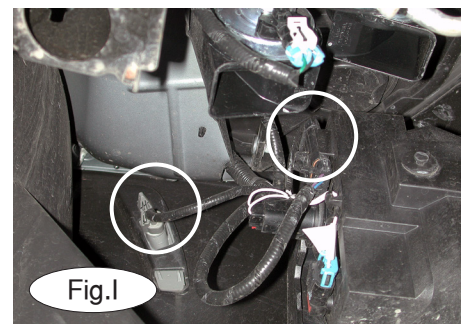



BASEPLATE KIT INSTALLATION INSTRUCTIONS

KIT# 3128-3

04/15/14
KS

ROADMASTER, Inc. 6110 NE 127th Ave. Vancouver, WA 98682 360-896-0407 fax 360-735-9300 www.roadmasterinc.com

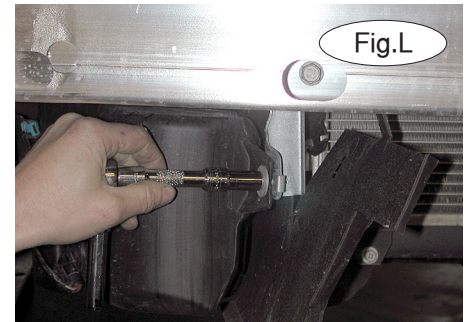
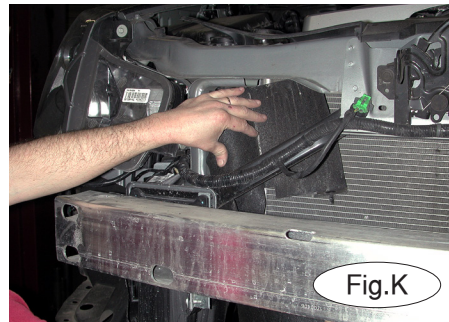
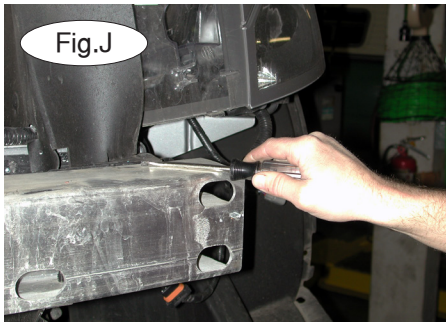

8. Remove two plastic fasteners, on each side (Fig.J), attaching the air deflectors to the bumper core, so that the air deflectors can be pulled to one side (Fig.K).

9. Remove the bumper core – First, remove one 10mm bolt on the water bottle support bracket, on the passenger side (Fig.L). Next, remove the four 13mm head nuts on each side which connect the bumper core to the frame horns (Fig.M). Remove the bumper core (Fig.N).

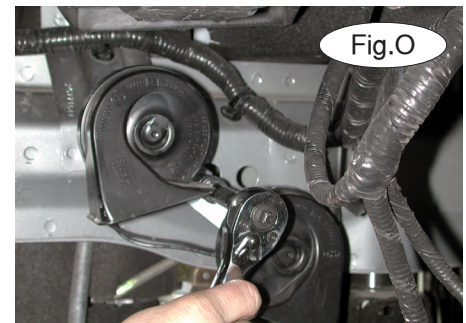
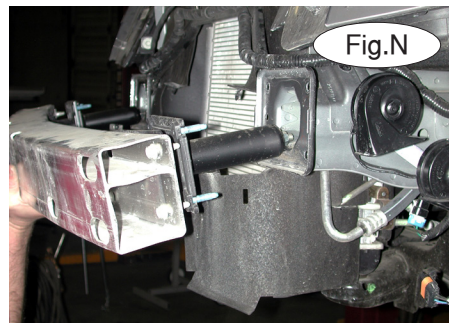
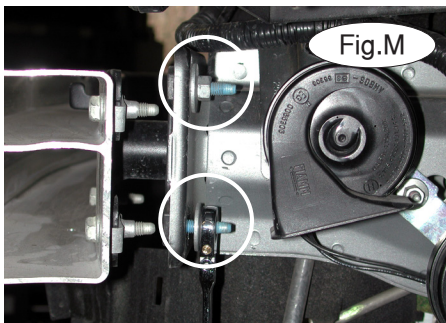

10. On the driver side, remove one 10mm bolt to remove the horn (Fig.O).

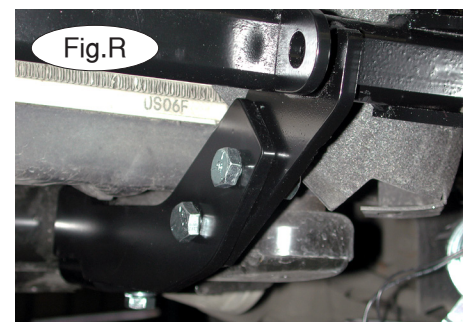
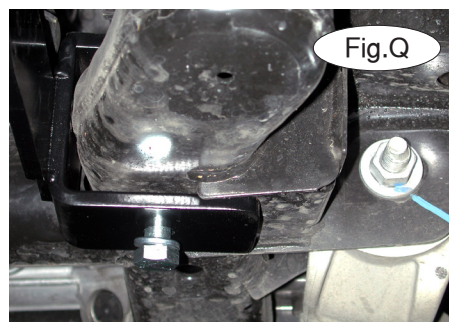
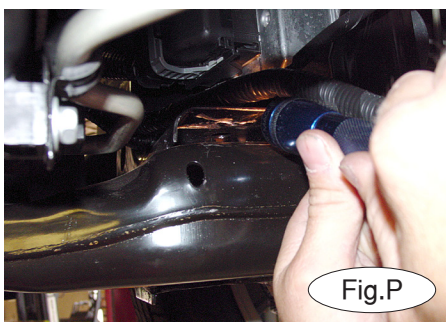

11. On the passenger side, use a file or a die-grinder to remove a metal tab on the subframe (Fig.P).

12. Fit the two lower braces to the subframe – Slide the braces between the frame and the subframe, and bolt each one in place with one of the supplied 1/2" x 4" bolts and 1/2" lock washers through the existing holes in the subframe (Fig.Q). Finger-tighten only at this time.

13. Attach the main brace – The brace fits between the radiator and the frame rail on the passenger side, and to the outside of the frame rail on the driver side. Bolt the main brace to the lower braces with two 1/2" x 1 1/4" bolts, lock washers and nuts on each side (Fig.R).



BASEPLATE KIT INSTALLATION INSTRUCTIONS

KIT# 3128-3

04/15/14
KS

ROADMASTER, Inc. 6110 NE 127th Ave. Vancouver, WA 98682 360-896-0407 fax 360-735-9300 www.roadmasterinc.com

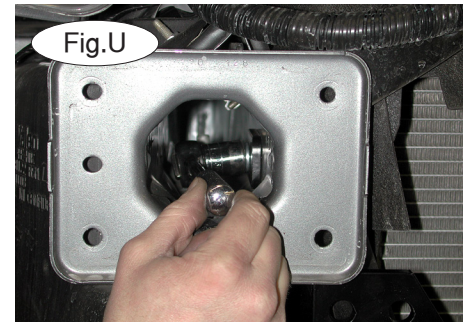
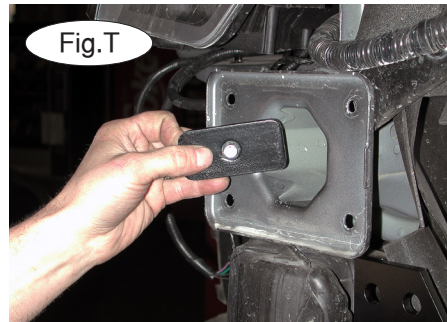
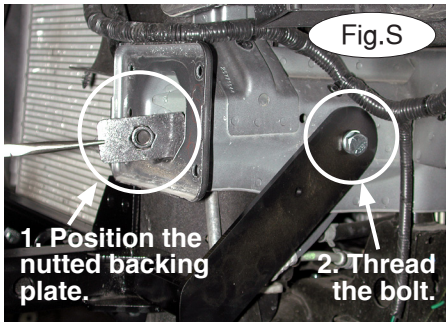

14. Attach the side braces to the frame rails – Starting with the driver side, thread one of the supplied $\frac{1}{2}$ " x $1\frac{1}{4}$ " bolts and lock washers through the pre-drilled hole in the side brace, and through the existing hole in the frame rail (Fig.S). Next, position the $1\frac{1}{2}$ " x 3" nutted backing plate over the bolt (Fig.S). Thread the bolt onto the backing plate. Finger-tighten only at this time.

For the passenger side, thread a $\frac{1}{2}$ " x $1\frac{1}{4}$ " bolt and lock washer onto the $1\frac{1}{2}$ " x 3" backing plate, and position it over and into the pre-existing hole in the frame rail (Fig.T). The hole on this side brace is threaded. Use a ratchet or a ratcheting wrench to thread the bolt onto the brace (Fig.U).

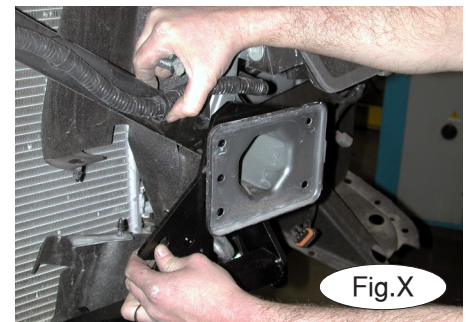
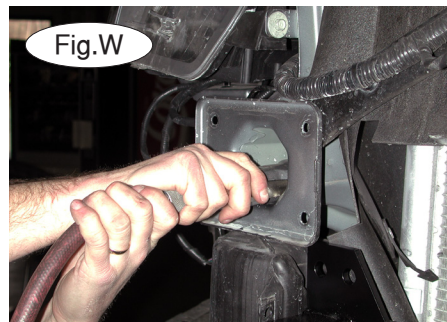
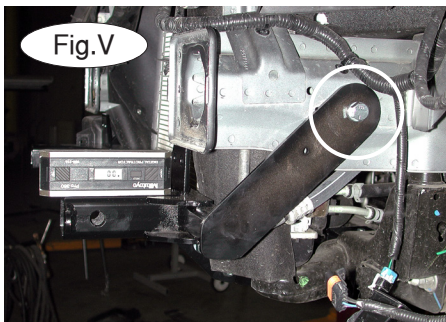

15. Level the bracket (Fig.V). Then, tighten the driver side brace bolt (Fig.V) to the torque specifications at the bottom of these instructions.

16. Once the passenger side bolt has been threaded onto the side brace, use an air ratchet to tighten the bolt (Fig.W) to the torque specifications at the bottom of these instructions.

17. Tighten all bolts to the torque specifications at the bottom of these instructions.

18. Attach the upper braces to the main brace – Slide both the driver side and the passenger side upper braces between the hood latch support and the frame horn (Fig.X).

19. Once they are in position, secure both of the upper braces to the main brace with two $\frac{7}{16}$ " x $1\frac{1}{4}$ " bolts, flat washers, lock washers and nuts (Fig.Y).

20. Trim the water bottle bracket on the bumper core, using the black mark in Figure Z as a reference.

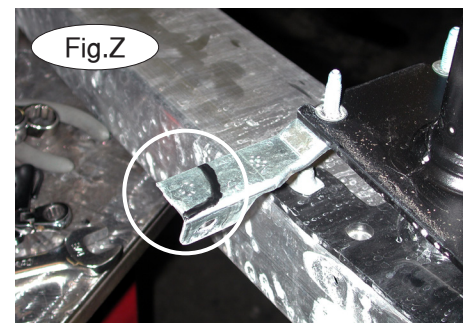
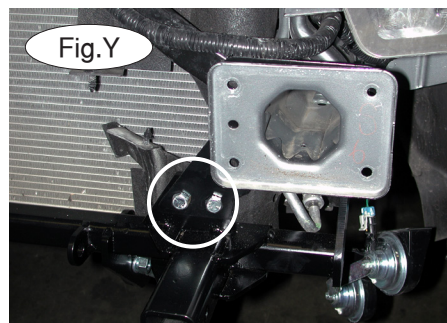



BASEPLATE KIT INSTALLATION INSTRUCTIONS

KIT# 3128-3

04/15/14
KS

ROADMASTER, Inc. 6110 NE 127th Ave. Vancouver, WA 98682 360-896-0407 fax 360-735-9300 www.roadmasterinc.com

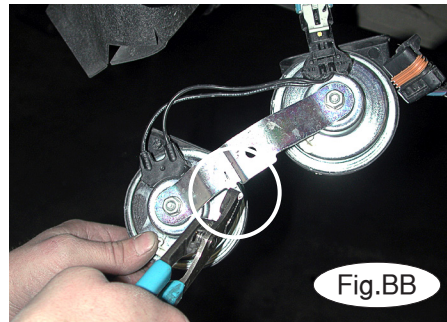
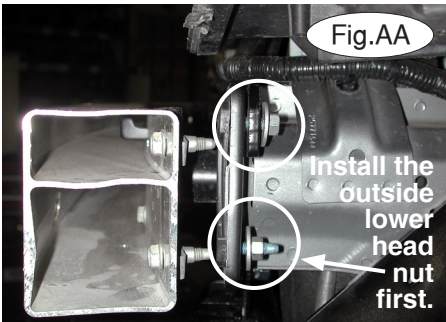

21. Remount the bumper core, sliding it through the end of both frame horns and through the upper braces (Fig.AA). Apply thread lock to the outside lower 13mm head nuts which you removed in step 9, and bolt them back into place (Fig. AA). Then, apply thread lock to the remaining nuts (three on each side) and bolt them in place. Torque all eight bolts to the specifications at the bottom of these instructions.
22. Remount the horn – First, bend the alignment tab indicated in Figure BB. Bolt the horn to the bracket side brace, through the existing hole, using the supplied 6mm x 1.0 x 25mm bolt and lock nut.
23. Trim both of the air deflectors to accommodate the main brace, reposition them, and reinstall the plastic fasteners you removed in step 8. Trim the center splash shield as well, and then remount the center splash shield (Fig.CC), reversing step 3.
24. Remove the grille insert (Fig.DD) or trim the inside section of the grille insert so that the front receiver braces will fit through the grille.
25. Reinstall the fascia, reversing steps 1 through 2 and 4 through 7.
26. Fit the front bracket arms into the front receiver braces, and secure them in place with the supplied 5/8" draw pins and spring pins.
27. Install the tow bar to the mounting bracket according to the manufacturer's instructions. Attach the safety cables to the main receiver brace.



BOLT TORQUE REQUIREMENTS

Note: The torque values represented below are intended as general guidelines. Torque requirements for specific applications may vary. Roadmaster does not warrant this information to be accurate for all applications and disclaims all liability for any claims or damages which may result from its use.

STANDARD BOLTS

Thread Size	Grade	Torque
5/16.....	5.....	13 ft./lb.
3/8.....	5.....	23 ft./lb.
7/16.....	5.....	37 ft./lb.
1/2.....	5.....	56 ft./lb.
5/8.....	5.....	150 ft./lb.

METRIC BOLTS

Thread Size	Grade	Plated / Unplated
8mm-1.0	8.8	20 ft./lb. 18 ft./lb.
8mm-1.25	8.8	19 ft./lb. 18 ft./lb.
10mm-1.25	8.8	38 ft./lb. 36 ft./lb.
10mm-1.5	8.8	37 ft./lb. 35 ft./lb.

METRIC BOLTS

Thread Size	Grade	Plated / Unplated
12mm-1.25	8.8	70 ft./lb. 65 ft./lb.
12mm-1.5	8.8	66 ft./lb. 61 ft./lb.
12mm-1.75	8.8	65 ft./lb. 60 ft./lb.
14mm-2.0	8.8	104 ft./lb. 97 ft./lb.