



BASEPLATE KIT INSTALLATION INSTRUCTIONS

KIT# 3132-1

12/22/04
RV

ROADMASTER, Inc. 6110 NE 127th Ave. Vancouver, WA 98682 1-800-669-9690 fax 360-735-9300 www.roadmasterinc.com

ROADMASTER, INC.

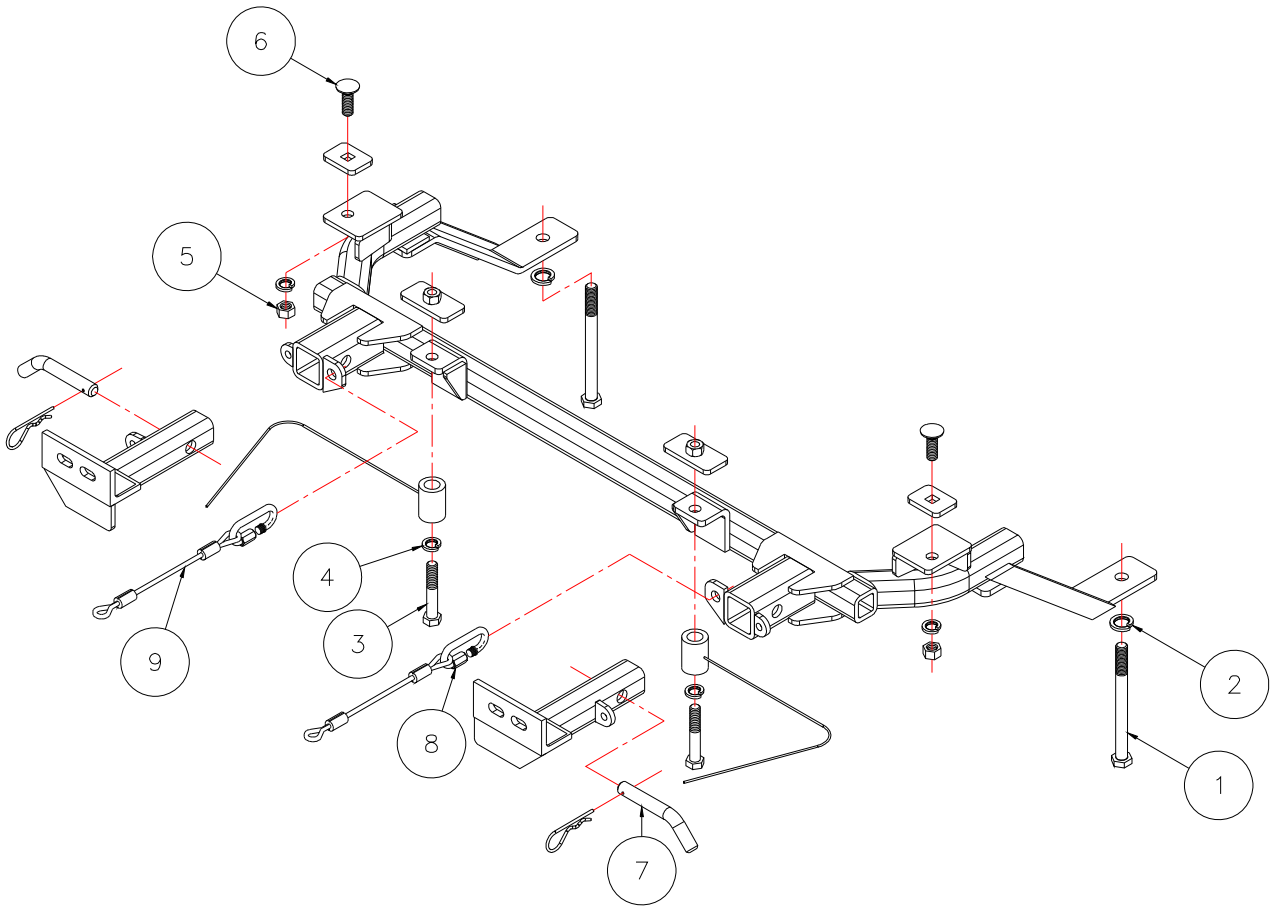

Item	Qty.	Length	Width	Description	Part#
1	2	160mm	14mm	14mm x 2.0 x 160mm BOLT	355910-16
2	2		14mm	LOCK WASHER	355740-00
3	2	3"	1/2"	1/2" x 3" BOLT	350101-00
4	4		1/2"	LOCK WASHER	350309-00
5	2		1/2"	NUT	350258-00
6	2	1 1/2"	1/2"	1/2" x 1 1/2" CARRIAGE BOLT	350362-00
7	2		5/8"	DRAW PINS, SPRING PINS	357035-00
8	2			CABLE CONNECTOR	200008-00
9	2	8"		SAFETY CABLE	500646-08



BASEPLATE KIT INSTALLATION INSTRUCTIONS

KIT# 3132-1

12/22/04
RV

ROADMASTER, Inc. 6110 NE 127th Ave. Vancouver, WA 98682 1-800-669-9690 fax 360-735-9300 www.roadmasterinc.com

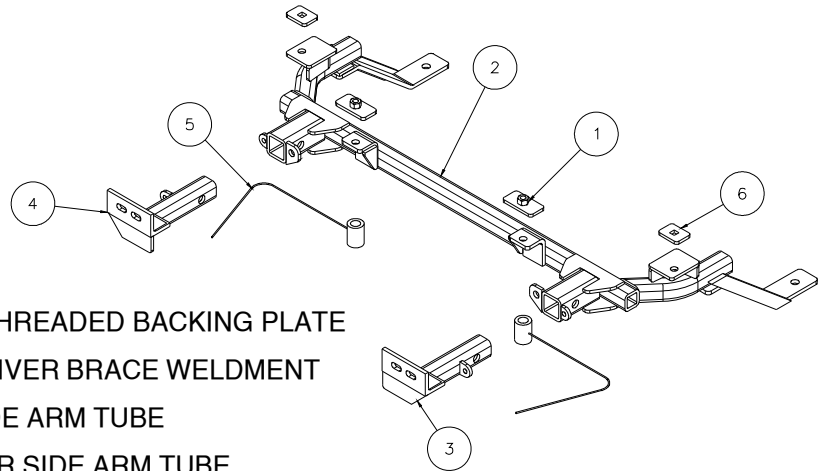

Item	Qty.	Part #	Description
1	2	C-000413	1 1/2" x 3" THREADED BACKING PLATE
2	1	C-001155	MAIN RECEIVER BRACE WELDMENT
3	1	C-001156	DRIVER SIDE ARM TUBE
4	1	C-001157	PASSENGER SIDE ARM TUBE
5	2	C-001158	TUBE SPACER WITH HANDLE
6	2	A-000039	1 1/2" x 2" BACKING PLATE

IMPORTANT: All baseplates **must** be assembled with all the bolts left loose for final adjustment and positioning (before tightening) unless otherwise instructed. All bolts **must** be torqued for proper strength. If more than one bolt is used per fastening point, the diagram may only show one. Use flat washers over all slotted holes and lock washers on all fasteners.

WARNING

Failure to heed these warnings or follow the installation instructions may result in a voided warranty, loss of towed vehicle, personal injury or death.

- Do not weld or modify this baseplate or its components. Welding or modification will void the warranty.
- Do not use this document as a basis to design/fabricate a baseplate, as it may not show all parts or structural components.
- We strongly recommend professional installation.
- If the towed vehicle has been in an accident, it must be properly repaired before attaching the baseplate. Do not install the baseplate if any structural frame damage is found.
- The installer must use all bolts and parts supplied. If running changes were made by the vehicle manufacturer after this kit was designed, some bolts or other fasteners may no longer be the correct size. It is the installer's responsibility to verify this kit is securely fastened to the vehicle.
- Use Loctite® Red on all bolts used to secure this baseplate. Torque all bolts to the specifications found at the end of these instructions. Do not over-torque the bolts or failure may occur.
- The installer must inspect the baseplate to ensure adequate clearance, particularly around hoses, air conditioner lines, radiators, etc. or non-warranty failure may result.
- Roadmaster manufactures many styles of baseplates. If your baseplate has removable arms, they must be removed before driving the vehicle, unless the arms can be pinned or padlocked in place. If not secured, the arms could vibrate out.
- Some motorhome chassis have such a tight turning radius that you can damage your motorhome, towed vehicle, tow bar or baseplate while turning sharply. Before getting on the road, test your turning radius in an empty parking lot. Turning too sharply could

result in non-warranty damage to your towing system, motorhome and/or towed vehicle.

- Do not back up with the towed vehicle attached or non-warranty damage will occur to your towing system or vehicles.
- The safety cables must connect the towing vehicle to the towed vehicle frame to frame, with the cables crossed, with enough slack for sharp turns. See cable instructions for proper routing. Failure to do so will result in non-warranty damage and/or the loss of the towed vehicle.
- This kit is designed for use with ROADMASTER tow bars and ROADMASTER adapters only. Using this kit with other brands, without an approved ROADMASTER adapter, may result in non-warranty damage or injury.
- Receiver extensions and out-of-level towing situations of 3 inches or more. This can cause the system to swing much higher and lower, causing excessive strain on the tow bar, baseplate and frame. That can cause the towing system to fail, causing property damage, personal injury or even death. If you must use a receiver extension or drop hitch to tow, it will reduce your receiver's weight capacity by 1/3 to avoid damaging your system. Never use more than one extension and/or drop hitch, as this will void your warranty.
- Every 3,000 miles, the owner must inspect all mounting points for cracks or fatigue, and check the fasteners for proper torque, according to the bolt torque requirements chart on the last page of these instructions.
- The owner must follow the vehicle manufacturer's instructions to prepare the vehicle for towing. Failure to do so may cause severe damage to the vehicle.
- This baseplate is only warranted for the original installation. Installing a used baseplate on another vehicle is not recommended and will void the warranty.



BASEPLATE KIT INSTALLATION INSTRUCTIONS

KIT# 3132-1

12/22/04
RV

ROADMASTER, Inc. 6110 NE 127th Ave. Vancouver, WA 98682 1-800-669-9690 fax 360-735-9300 www.roadmasterinc.com

This is one of our XL series brackets, which allows the visible front portion of the brackets to be easily removed from the front of the vehicle (Fig.A and Fig.B). The bracket kit consists of a main receiver brace, two removable front bracket arms and a hardware pack.

Before starting the installation, lay out the kit components in order, as they will be used. This will give you a visual idea of how the components work, and will also confirm that everything is present and accounted for.

1. **Important: please use all supplied bolts and parts and read all instructions carefully before beginning this installation. The majority of questions you may have can be answered within the text, and proper installation will ensure safe and secure travel.** Now, begin the installation by removing six plastic fasteners along the top of the fascia (Fig.C).

2. Remove the seven 7mm (head) bolts connecting the splash shield to the lower fascia (Fig.D).

3. Remove four plastic fasteners – one on each side attaching the splash shield to the radiator support (Fig.E), and one on each side attaching the center air deflector to the outside air deflectors (Fig.F). Then, remove the center splash shield (Fig.G).

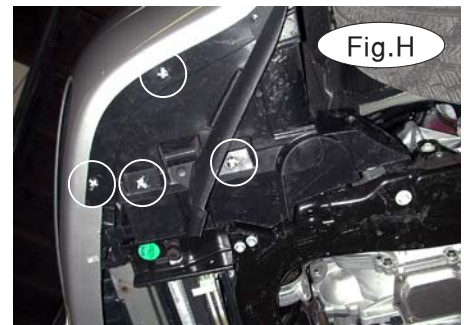
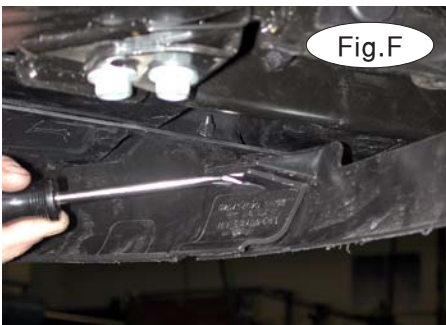

4. Remove four plastic fasteners from each outer splash shield (Fig.H), allowing the outer splash shields to be moved out of the way.

5. From behind the fascia, remove the 10mm (head) bolt connecting the fender to the fascia. This bolt is close to where the headlight, fascia and fender intersect. Figure I shows the location of the driver's side bolt. Repeat for the other side.

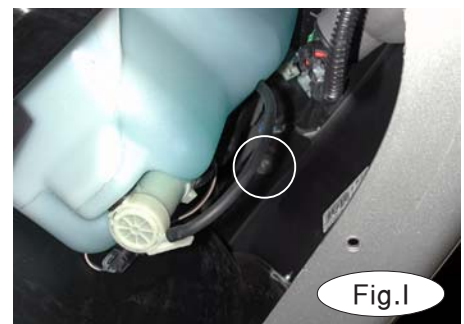



BASEPLATE KIT INSTALLATION INSTRUCTIONS

KIT# 3132-1

12/22/04
RV

ROADMASTER, Inc. 6110 NE 127th Ave. Vancouver, WA 98682 1-800-669-9690 fax 360-735-9300 www.roadmasterinc.com

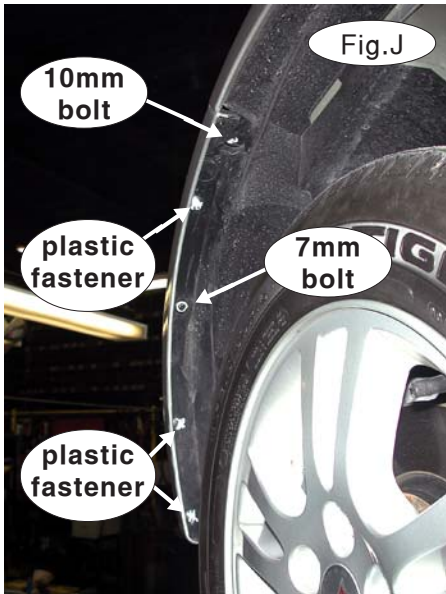

6. Then, from the outside of each fender well, remove three plastic fasteners, one 7mm (head) bolt, and one 10mm (head) bolt (Fig.J).
7. Disconnect the fog lights, if the vehicle is so equipped (Fig.K).
8. Pull down and forward to remove the fascia (Fig.L)



9. Trim both the driver side and the passenger side air deflectors – start by cutting away the sections marked with an 'X' in Figures M and N. Once the main receiver brace is bolted into place, trim the air deflectors to fit, as shown in Figure O.

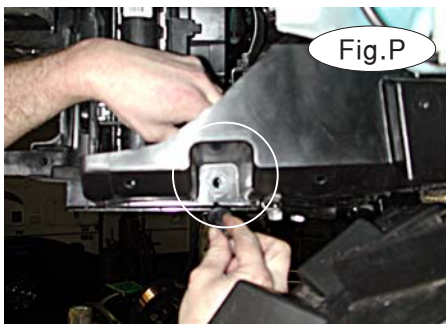

10. On each side, remove one plastic fastener holding the air deflector to the radiator support (Fig.P).
11. Support the subframe (Fig.Q).
12. On each side, remove a 21mm (head) bolt and bushing cup from the subframe (Fig.R).



BASEPLATE KIT INSTALLATION INSTRUCTIONS

KIT# 3132-1

12/22/04
RV

ROADMASTER, Inc. 6110 NE 127th Ave. Vancouver, WA 98682 1-800-669-9690 fax 360-735-9300 www.roadmasterinc.com



Fig.S

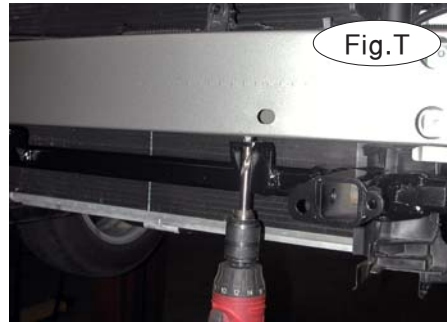
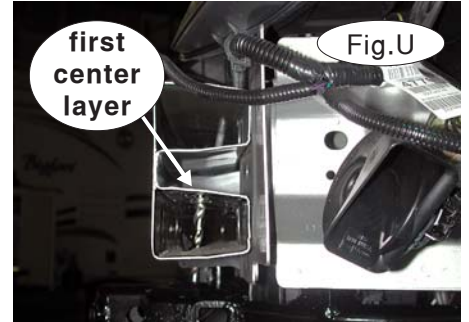

Fig.T



first center layer

Fig.U

13. Position the main receiver brace so that the pre-drilled holes at the rear of the brace align with the holes for the 21mm subframe bolts you removed in the preceding step.
14. Apply Loctite to one of the supplied 14mm x 2.0 x 160mm bolts. With the bushing cup between the main receiver brace and the bushing, thread the bolt and one of the supplied 14mm lock washers into one of the holes for the subframe bolts you removed in step 12 (Fig.S). Torque the bolt to the specifications at the bottom of these instructions. Repeat for the other side.
15. Using the pre-drilled hole in the main receiver brace as a template, drill a 17/32" hole through the bottom of the bumper core (Fig. T) and through the first center layer (Fig.U). Repeat for the other side.

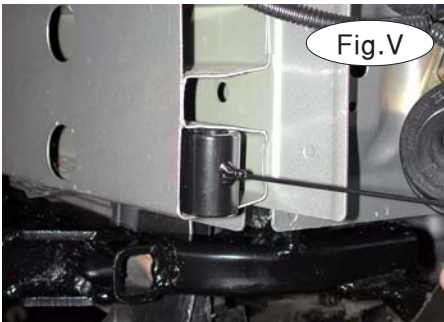

Fig.V

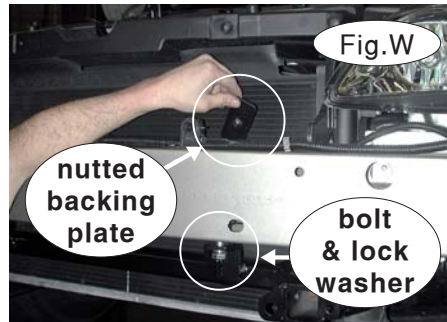

Fig.W

nutted backing plate

bolt & lock washer

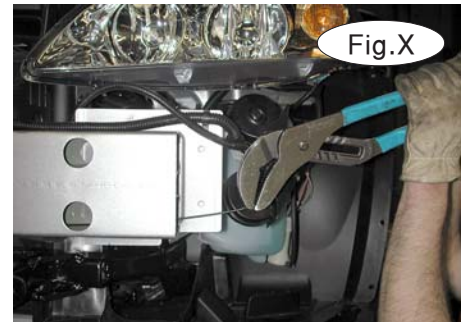

Fig.X

16. Using the attached wire, position one of the supplied 1 1/4" x 1 3/4" pipe spacers into the bumper core (Fig.V) and directly over one of the holes you drilled in the preceding step.
17. From the bottom of the bumper core, fit one of the supplied 1/2" x 3" bolts and 1/2" lock washers through the main receiver brace, pipe spacer and first center layer of the bumper core (Fig.W). From the back of the bumper core, fit one of the supplied 1 1/2" x 3" nutted backing plates over the first center layer of the bumper core (Fig.W) and over the bolt. Thread the bolt into the backing plate, then torque to the specifications at the bottom of these instructions. Repeat for the other side.

18. Once the bolts are tightened, break the wires off with a pair of pliers, either through each end of the bumper core (Fig.X), or through one of the access holes at the front of the bumper core.

19. Using the pre-drilled hole in the main receiver brace (Fig.Y) as a template, drill a 17/32" hole through the frame rail (Fig.Z). Repeat for the other side.



Fig.Y

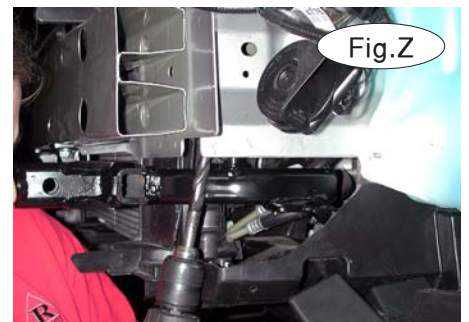

Fig.Z



BASEPLATE KIT INSTALLATION INSTRUCTIONS

KIT# 3132-1

12/22/04
RV

ROADMASTER, Inc. 6110 NE 127th Ave. Vancouver, WA 98682 1-800-669-9690 fax 360-735-9300 www.roadmasterinc.com

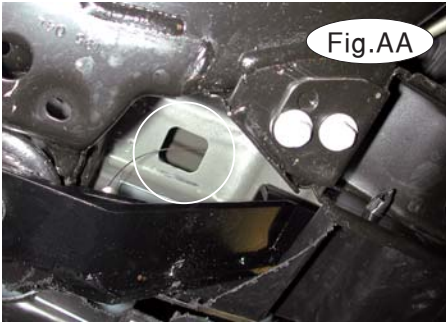

Fig.AA

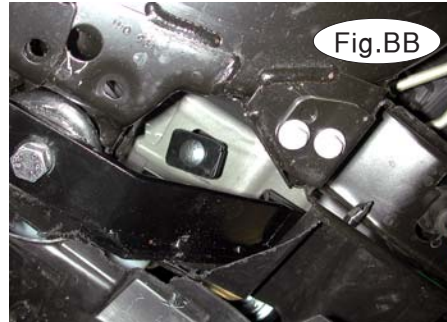

Fig.BB



Fig.CC

20. Then, fishwire one of the supplied 1/2" x 1 1/2" carriage bolts and 1 1/2" x 2" backing plates through the square opening in the frame rail (Fig.AA, Fig.BB) and through one of the holes you drilled in the preceding step. Thread a 1/2" lock washer and nut over the bolt (Fig.CC), and torque the bolt to the specifications at the bottom of these instructions. Repeat for the other side.

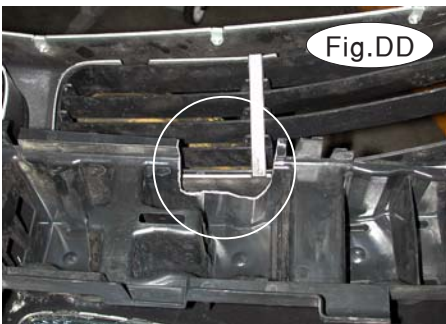

Fig.DD



Fig.EE



Fig.FF

- 21. Replace the plastic fasteners holding the air deflectors to the radiator support, which you removed in step 10.
- 22. Before reinstalling the fascia, trim the section below the grill shown in Figure DD, on both sides. Then, remove a section of the top horizontal rib from the grille, on both the driver side and the passenger side, as shown in Figure EE.
- 23. Reinstall the fascia and the center splash shield by reversing steps 1 through 8.
- 24. Fit the front bracket arms into the front receiver braces, and secure them in place with the supplied 5/8" draw pins and spring pins.
- 25. Attach the 8" safety cables with the cable connectors (Q-Links) to the front of the receiver braces (Fig.FF).
- 26. Attach the ends of the safety cables to the tow vehicle's safety cables and tow bar.
- 27. Install the tow bar to the mounting bracket according to the manufacturer's instructions.

BOLT TORQUE REQUIREMENTS

Note: The torque values represented below are intended as general guidelines. Torque requirements for specific applications may vary. Roadmaster does not warrant this information to be accurate for all applications and disclaims all liability for any claims or damages which may result from its use.

STANDARD BOLTS

Thread Size	Grade	Torque
5/16	5	13 ft./lb.
3/8	5	23 ft./lb.
7/16	5	37 ft./lb.
1/2	5	56 ft./lb.
5/8	5	150 ft./lb.

METRIC BOLTS

Thread Size	Grade	Plated / Unplated
8mm-1.0	8.8	20 ft./lb. 18 ft./lb.
8mm-1.25	8.8	19 ft./lb. 18 ft./lb.
10mm-1.25	8.8	38 ft./lb. 36 ft./lb.
10mm-1.5	8.8	37 ft./lb. 35 ft./lb.

METRIC BOLTS

Thread Size	Grade	Plated / Unplated
12mm-1.25	8.8	70 ft./lb. 65 ft./lb.
12mm-1.5	8.8	66 ft./lb. 61 ft./lb.
12mm-1.75	8.8	65 ft./lb. 60 ft./lb.
14mm-2.0	8.8	104 ft./lb. 97 ft./lb.

All illustrations and specifications contained herein are based on the latest information available at the time of publication approval. ROADMASTER, INC. reserves the right to make changes at any time without notice in material, specification and models or to discontinue models.