



# BASEPLATE KIT INSTALLATION INSTRUCTIONS

**KIT# 3165-3**

04/06/11  
KS

ROADMASTER, Inc. 6110 NE 127th Ave. Vancouver, WA 98682 360-896-0407 fax 360-735-9300 www.roadmasterinc.com

ROADMASTER, INC.

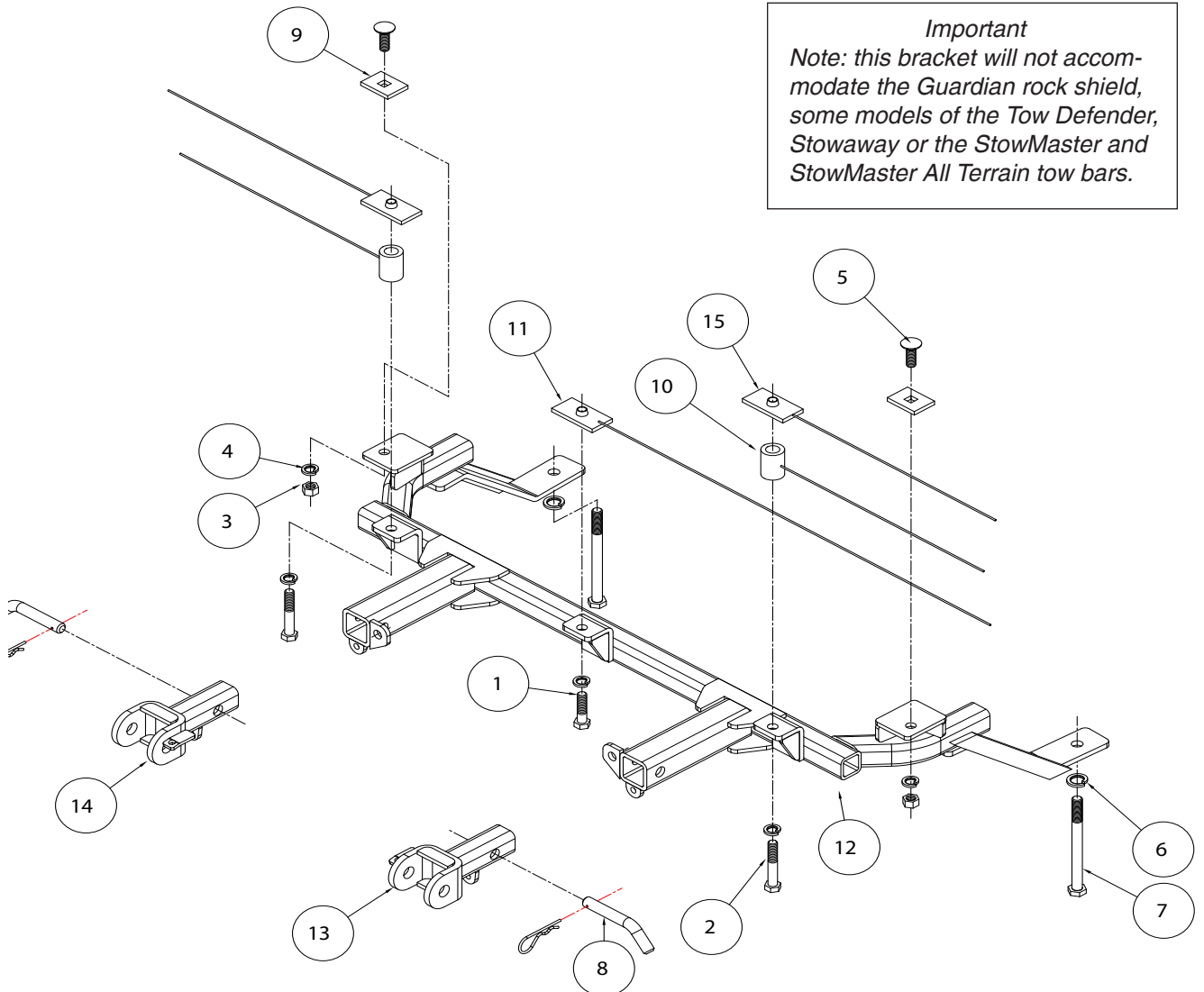

**Important**  
*Note: this bracket will not accommodate the Guardian rock shield, some models of the Tow Defender, Stowaway or the StowMaster and StowMaster All Terrain tow bars.*

ITEM	QTY	NAME	MATERIAL
1.....	1	1/2" X 1 1/2" BOLT	350095-00
2.....	2	1/2" x 3" BOLT	350101-00
3.....	2	1/2" HEX NUT	350258-00
4.....	5	1/2" LOCK WASHER	350309-00
5.....	2	1/2" x 1 1/2" CARRIAGE BOLT	350362-00
6.....	2	14mm LOCK WASHER	355740-00
7.....	2	14mm x 2.0 x 160 BOLT	355910-16
8.....	2	DRAW PINS, SPRING PINS	357035-00
9.....	2	1/4" x 1 1/2" x 2" SQUARE HOLE BACKING PLATE	A-000039
10.....	2	1 1/4" x 1 3/4" PIPE SPACER W/ ROD	C-001158
11.....	1	1/4" x 1 1/2" x 3" THREADED BACKING PLATE W/ ROD	C-001841
12.....	1	MAIN RECEIVER	C-001952
13.....	1	DRIVER SIDE ARM	C-001651
14.....	1	PASSENGER SIDE ARM	C-001652
15.....	2	1/4" x 1 1/2" x 3" THREADED BACKING PLATE W/ ROD	C-001955



# BASEPLATE KIT INSTALLATION INSTRUCTIONS

**KIT# 3165-3**

04/06/11  
KS

ROADMASTER, Inc. 6110 NE 127th Ave. Vancouver, WA 98682 360-896-0407 fax 360-735-9300 www.roadmasterinc.com

This is one of our XL series brackets, which allows the visible front portion of the bracket to be easily removed from the front of the vehicle (Fig.A and Fig.B). The bracket consists of a main receiver brace, two removable front braces and a hardware pack.

The main receiver brace mounts to the bumper core and frame rails. The removable front braces install in the main receiver brace.

Before starting the installation, lay out the kit components in order, as they will be used. This will give you a visual idea of how the components work, and will also confirm that everything is present and accounted for.



**IMPORTANT:** All baseplates **must** be assembled with all the bolts left loose for final adjustment and positioning (before tightening) unless otherwise instructed. All bolts **must** be torqued for proper strength. If more than one bolt is used per fastening point, the diagram may only show one. Use flat washers over all slotted holes and lock washers on all fasteners.

## **WARNING**

Failure to heed these warnings or follow the installation instructions may result in a voided warranty, loss of towed vehicle, personal injury or death.

- Do not weld or modify this baseplate or its components. Welding or modification will void the warranty.
- Do not use this document as a basis to design/fabricate a baseplate, as it may not show all parts or structural components.
- We strongly recommend professional installation.
- If the towed vehicle has been in an accident, it must be properly repaired before attaching the baseplate. Do not install the baseplate if any structural frame damage is found.
- The installer must use all bolts and parts supplied. If running changes were made by the vehicle manufacturer after this kit was designed, some bolts or other fasteners may no longer be the correct size. It is the installer's responsibility to verify this kit is securely fastened to the vehicle.
- Use Loctite® Red on all bolts used to secure this baseplate. Torque all bolts to the specifications found at the end of these instructions. Do not over-torque the bolts or failure may occur.
- The installer must inspect the baseplate to ensure adequate clearance, particularly around hoses, air conditioner lines, radiators, etc. or non-warranty failure may result.
- Roadmaster manufactures many styles of baseplates. If your baseplate has removable arms, they must be removed before driving the vehicle, unless the arms can be pinned or padlocked in place. If not secured, the arms could vibrate out.
- Some motorhome chassis have such a tight turning radius that you can damage your motorhome, towed vehicle, tow bar or baseplate while turning sharply. Before getting on the road, test your turning radius in an empty parking lot. Turning too sharply could result in non-warranty damage to your towing system, motorhome and/or towed vehicle.
- Do not back up with the towed vehicle attached or non-warranty damage will occur to your towing system or vehicles.
- The safety cables must connect the towing vehicle to the towed vehicle frame to frame, with the cables crossed, with enough slack for sharp turns. See cable instructions for proper routing. Failure to do so will result in non-warranty damage and/or the loss of the towed vehicle.
- This kit is designed for use with ROADMASTER tow bars and ROADMASTER adapters only. Using this kit with other brands, without an approved ROADMASTER adapter, may result in non-warranty damage or injury.
- Receiver extensions and out-of-level towing situations of 3 inches or more. This can cause the system to swing much higher and lower, causing excessive strain on the tow bar, baseplate and frame. That can cause the towing system to fail, causing property damage, personal injury or even death. If you must use a receiver extension or drop hitch to tow, it will reduce your receiver's weight capacity by 1/3 to avoid damaging your system. Never use more than one extension and/or drop hitch, as this will void your warranty.
- Every 3,000 miles, the owner must inspect all mounting points for cracks or fatigue, and check the fasteners for proper torque, according to the bolt torque requirements chart on the last page of these instructions.
- The owner must follow the vehicle manufacturer's instructions to prepare the vehicle for towing. Failure to do so may cause severe damage to the vehicle.
- This baseplate is only warranted for the original installation. Installing a used baseplate on another vehicle is not recommended and will void the warranty.



# BASEPLATE KIT INSTALLATION INSTRUCTIONS

**KIT# 3165-3**

04/06/11  
KS

ROADMASTER, Inc. 6110 NE 127th Ave. Vancouver, WA 98682 360-896-0407 fax 360-735-9300 www.roadmasterinc.com



1. **Important:** please use all supplied bolts and parts and read all instructions carefully before beginning this installation. The majority of questions you may have can be answered within the text, and proper installation will ensure safe and secure travel. Now, begin the installation by removing six plastic fasteners along the top of the fascia (Fig.C).

2. Remove the seven 7mm (head) bolts connecting the splash shield to the lower fascia (Fig.D).

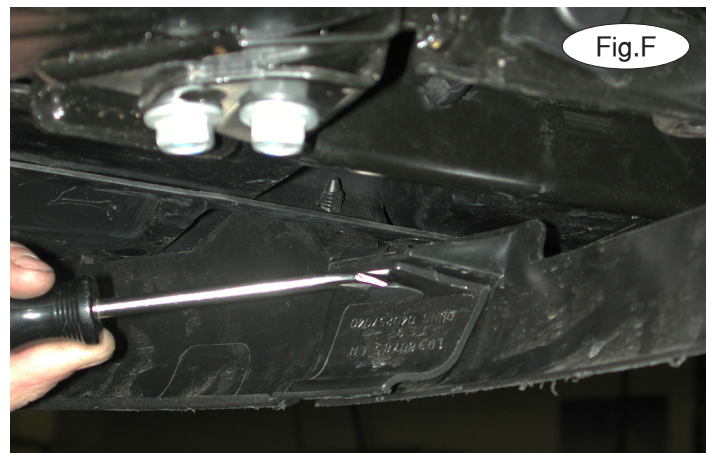

3. Remove four plastic fasteners – one on each side attaching the splash shield to the radiator support (Fig.E), and one on each side attaching the center air deflector to the outside air deflectors (Fig.F). Then, remove the center splash shield (Fig.G).

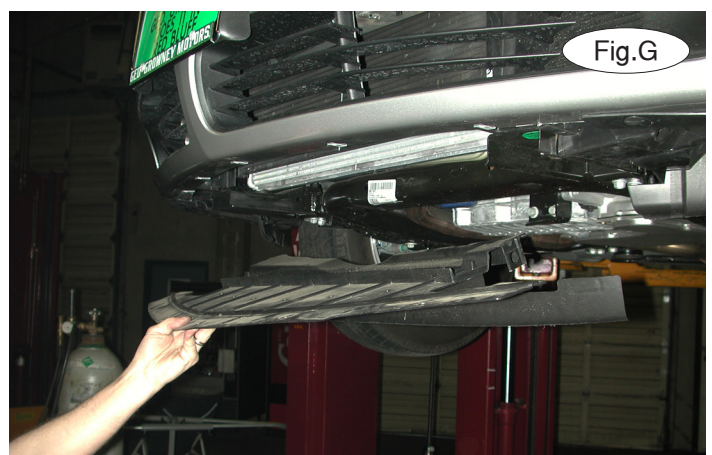



# BASEPLATE KIT INSTALLATION INSTRUCTIONS

**KIT# 3165-3**

04/06/11  
KS

ROADMASTER, Inc. 6110 NE 127th Ave. Vancouver, WA 98682 360-896-0407 fax 360-735-9300 www.roadmasterinc.com

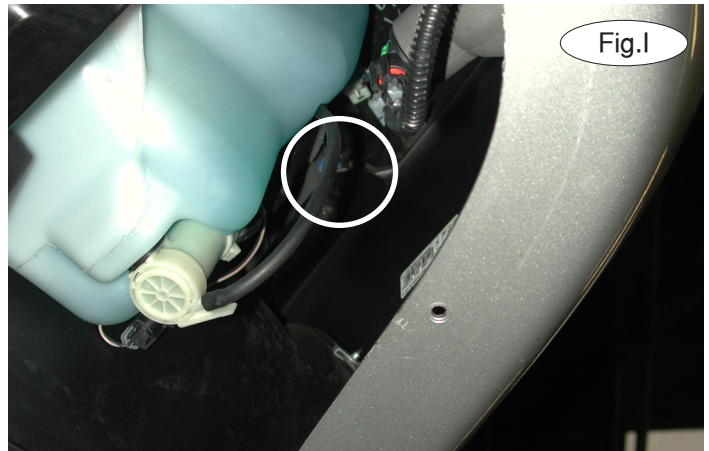
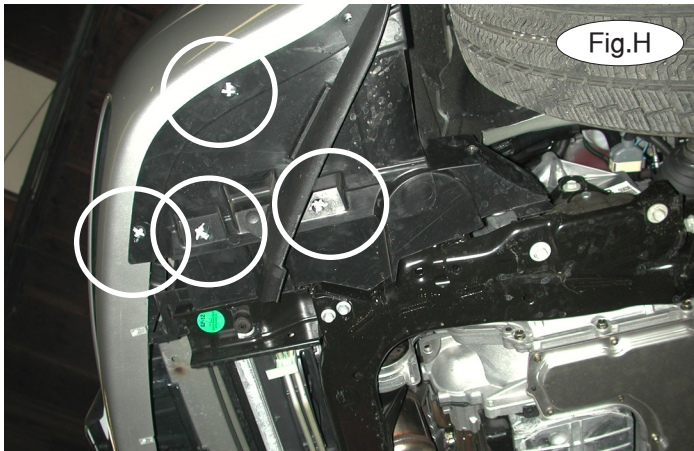

4. Remove four plastic fasteners from each outer splash shield (Fig.H), allowing the outer splashes to be moved out of the way.

5. On each side, remove the 10mm (head) bolt connecting the fender to the fascia. This bolt is close to where the headlight, fascia and fender intersect. Figure I shows the location of the driver's side bolt.

6. From the outside of each fender wall, remove three plastic fasteners, one 7mm (head) bolt and one 10mm (head) bolt (Fig.J).

7. Disconnect the fog lights, if the vehicle is so equipped (Fig.K).

8. Pull down and forward to remove the fascia (Fig.L).

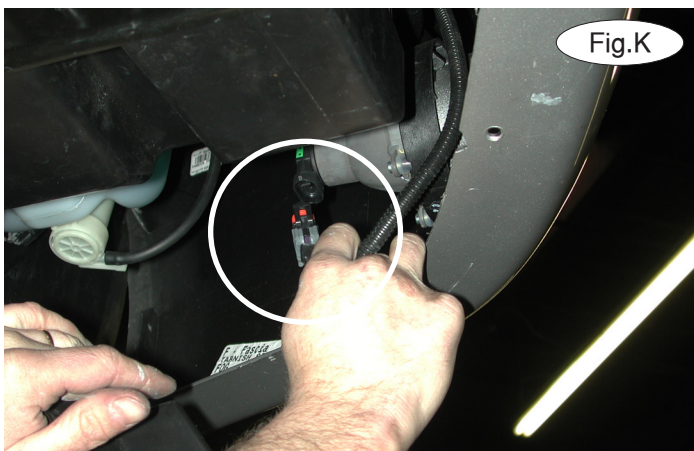
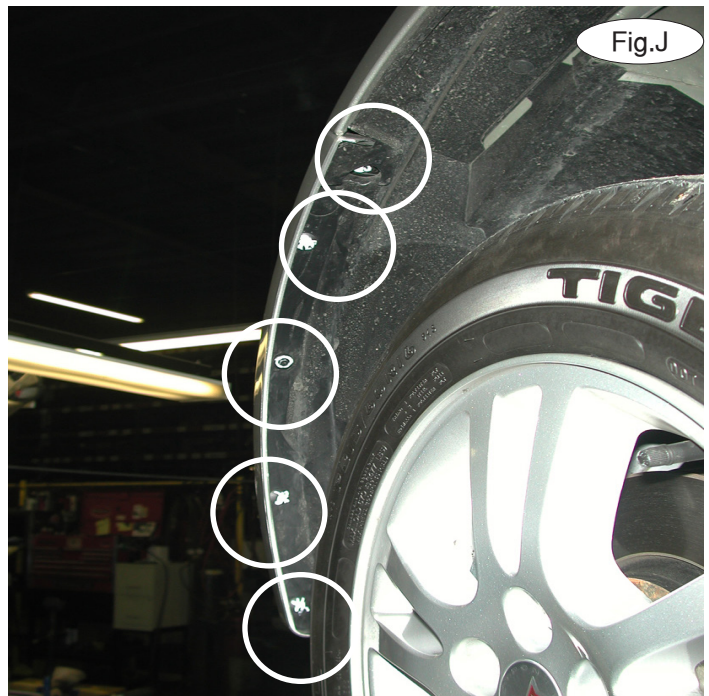



# BASEPLATE KIT INSTALLATION INSTRUCTIONS

**KIT# 3165-3**

04/06/11  
KS

ROADMASTER, Inc. 6110 NE 127th Ave. Vancouver, WA 98682 360-896-0407 fax 360-735-9300 www.roadmasterinc.com



9. Trim the air deflectors on both sides – start by cutting away the sections marked with an 'X' in Figures M and N. Once the main receiver brace is bolted into place, trim the air deflectors to fit, as shown in Figure O.

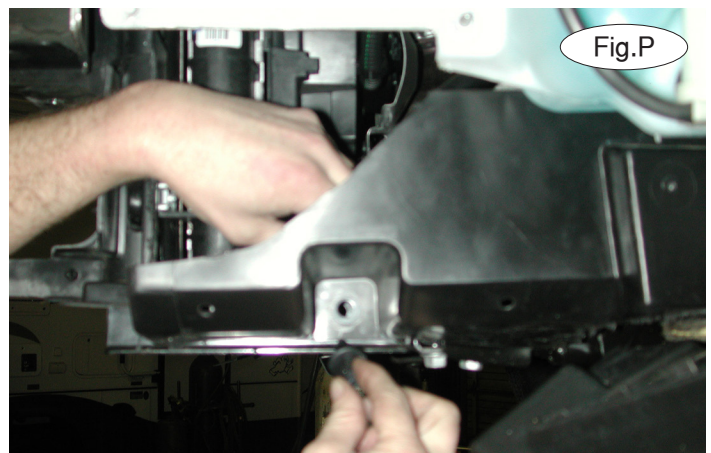

10. On each side, remove one plastic fastener holding the air deflector to the radiator support (Fig.P).
11. Support the subframe (Fig.Q).
12. On each side, remove a 21mm (head) bolt and bushing cup from the subframe (Fig.R). *Note:* the bolts will not be replaced. Retain the bolt so that they can be replaced if the bracket is ever removed.

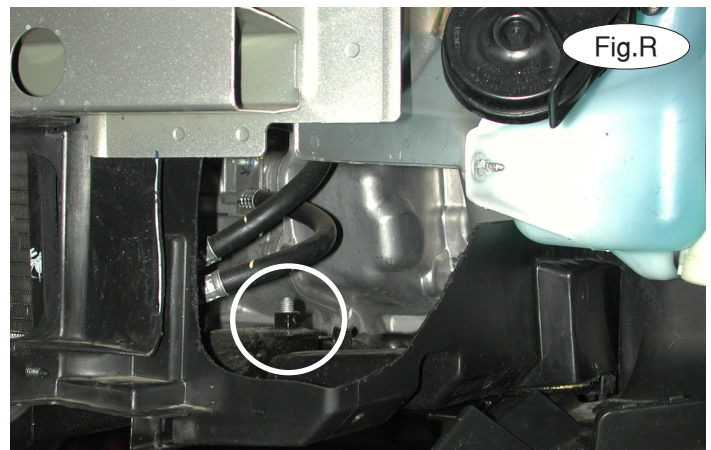
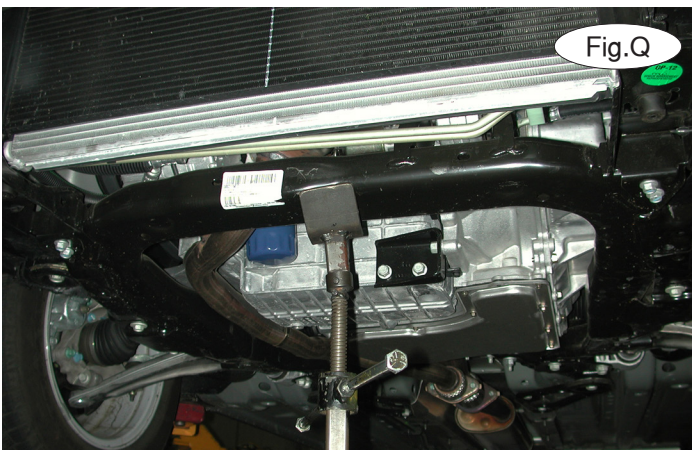



# BASEPLATE KIT INSTALLATION INSTRUCTIONS

**KIT# 3165-3**

04/06/11  
KS

ROADMASTER, Inc. 6110 NE 127th Ave. Vancouver, WA 98682 360-896-0407 fax 360-735-9300 www.roadmasterinc.com

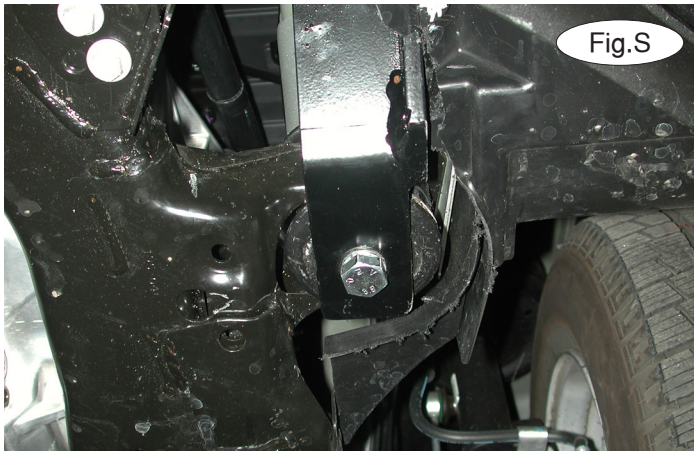

Fig.S

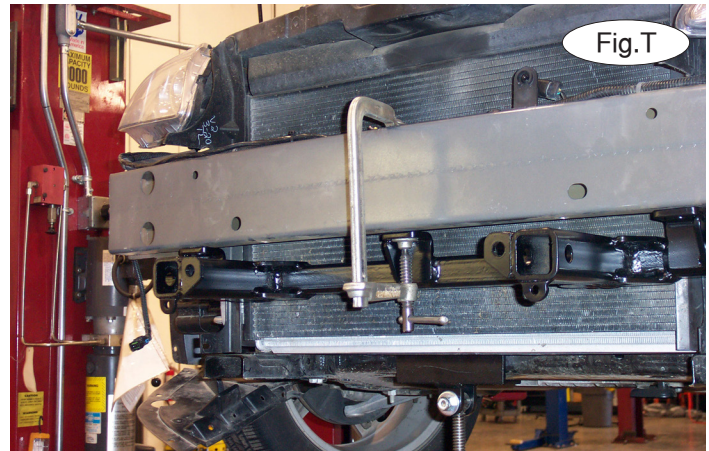

Fig.T

13. Working on one side at a time, use one of the supplied 14mm x 2.0 x 160mm bolts and 14mm lock washers, and bolt through the rear mounting point of the rear brace. Place the bushing cup between the main receiver brace and bushing and bolt into the subframe mounts (Fig.S).

14. Clamp the center mounting point of the main receiver brace to the bumper core (Fig,T).

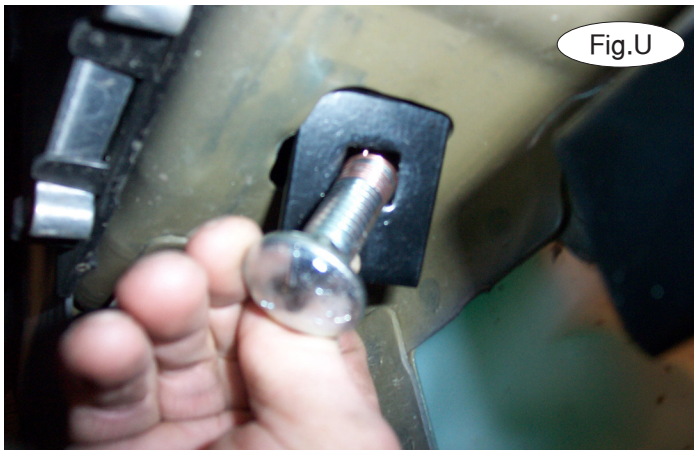

Fig.U



Fig.V

15. Working on the driver's side, fish wire a 1/2" x 1 1/2" carriage bolt and 1/4" x 1 1/2" x 2" backing plate through the square opening in the bottom of the frame rail and through the center outside mounting point of the brace (Fig.U). Finish with a 1/2" lock washer and nut (Fig.V).

16. Repeat step 15 for the passenger side of the vehicle. Torque all bolts to the bolt torque requirements found at the end of these instructions.

17. Remove the clamp from the center mounting point.

18. Using the three front mounting points of the main receiver brace as templates, drill a 1/2" hole through the first and second bumper core layers on the outside mounting points (Fig.W).



Fig.W

If you experience difficulty in drilling due to the hard composition of the bumper core, drill a pilot hole first. Make certain you use a sharp drill bit. *Note:* use a piece of metal as a buffer between the drill bit and the engine components.



# BASEPLATE KIT INSTALLATION INSTRUCTIONS

**KIT# 3165-3**

04/06/11  
KS

ROADMASTER, Inc. 6110 NE 127th Ave. Vancouver, WA 98682 360-896-0407 fax 360-735-9300 www.roadmasterinc.com

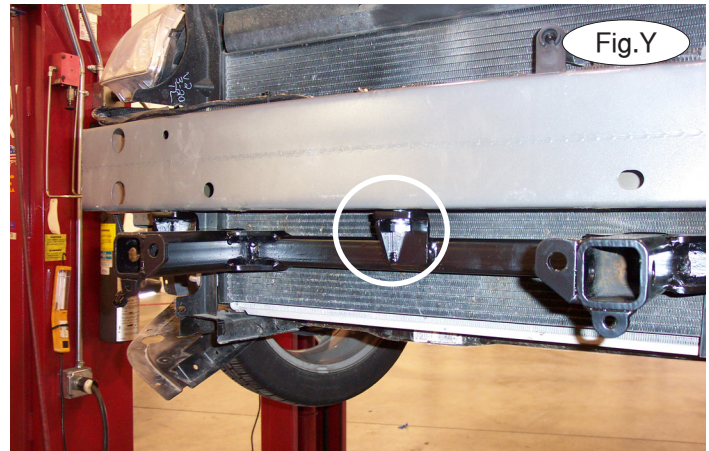
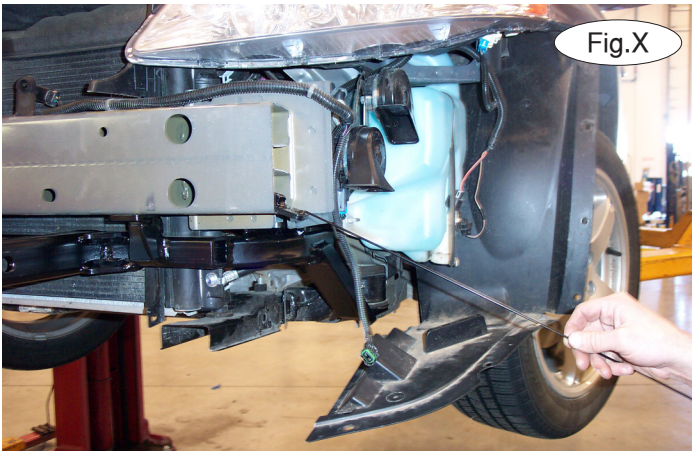

19. Place a  $\frac{1}{4}$ " x  $1\frac{1}{2}$ " x 3" nutted backing plate with wire through the opening in the end of the frame rail and over the opening you just drilled through the center mounting point (Fig.X). Now, bolt up through the main receiver brace, bumper core and into the backing plate using a  $\frac{1}{2}$ " x  $1\frac{1}{2}$ " bolt and  $\frac{1}{2}$ " lock washer (Fig.Y).

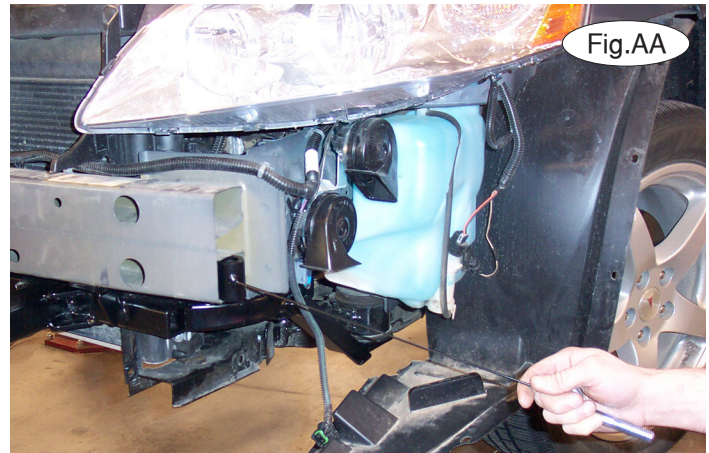
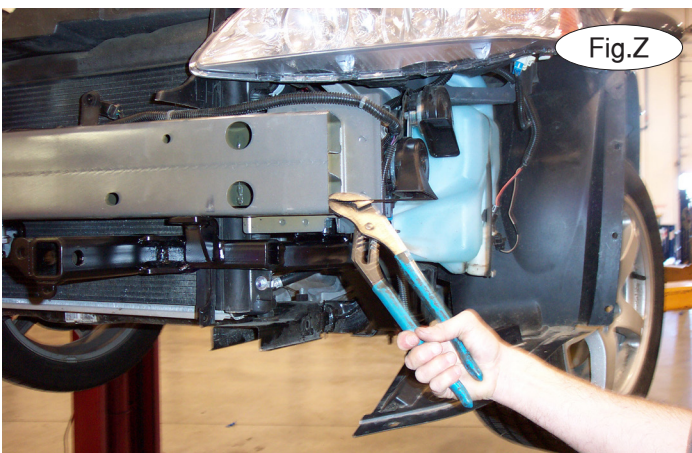

20. Using a pair of pliers, break the wire off the backing plate you just installed in step 19 (Fig.Z).

21. Working on the driver's side, place a  $\frac{1}{4}$ " x  $1\frac{3}{4}$ " pipe spacer in the end of the bumper core directly over the outside mounting point (Fig.AA).

22. Temporarily remove the plastic fastener at the top of the air deflector and move it to one side to allow easier access to the bumper core (Fig.BB).

23. Repeat steps 21 and 22 for the passenger side.

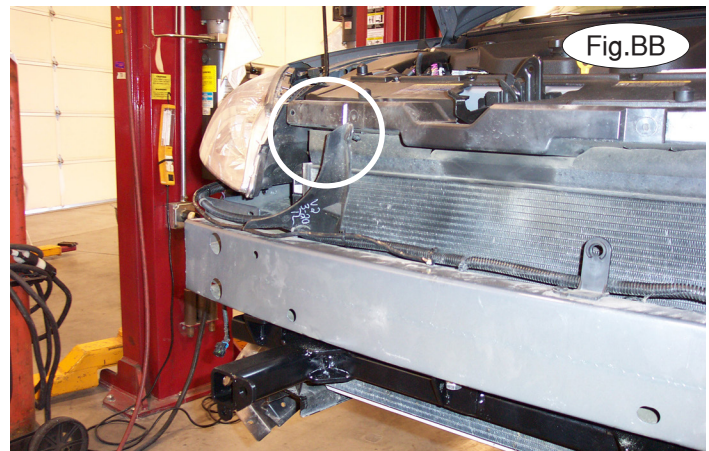



# BASEPLATE KIT INSTALLATION INSTRUCTIONS

**KIT# 3165-3**

04/06/11  
KS

ROADMASTER, Inc. 6110 NE 127th Ave. Vancouver, WA 98682 360-896-0407 fax 360-735-9300 www.roadmasterinc.com

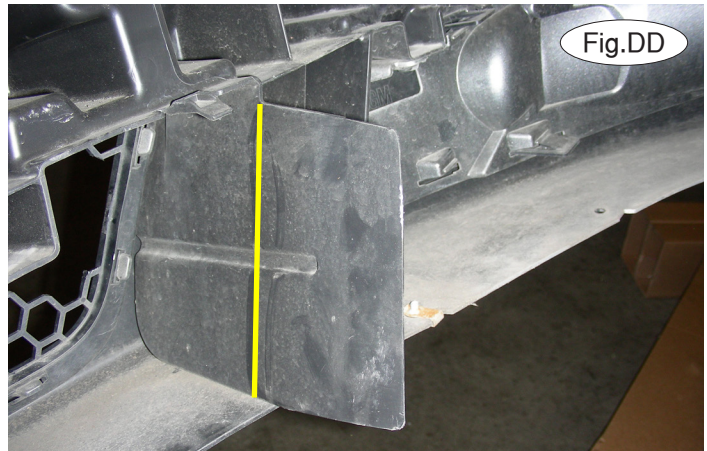
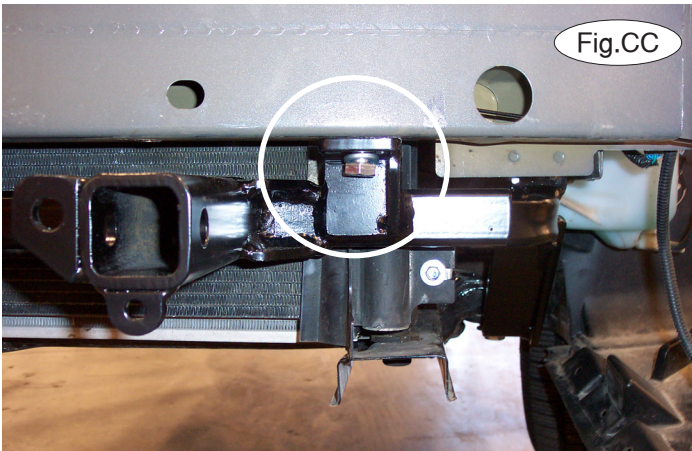

24. Place a 1/2" lock washer over the supplied 1/2" x 3" bolt. Place a 1/4" x 1 1/2" x 3" nutted backing plate with wire in the C-channel on top of the second layer opening in the back of the bumper core. Bolt up through the main receiver brace, pipe spacer, second layer of the bumper core and into the backing plate (Fig.CC).

25. Torque all bolts to the bolt torque requirements found at the end of these instructions. Use a pair of pliers to break the wires off the three backing plates in the bumper core.

26. Trim the air deflector on each side using the yellow line in Figure DD as a guide. Trim the fascia as shown in Figure EE. Now, reinstall the fascia, reversing steps 1 through 8.

27. Insert the removable front bracket arms into the front receiver braces, and secure them in place with the supplied 5/8" draw pins and spring pins.

28. Attach the 8" safety cables with the cable connectors (Q-Links) to the front of the receiver braces.

29. Attach the ends of the safety cables to the main receiver brace.



## BOLT TORQUE REQUIREMENTS

Note: The torque values represented below are intended as general guidelines. Torque requirements for specific applications may vary. Roadmaster does not warrant this information to be accurate for all applications and disclaims all liability for any claims or damages which may result from its use.

### STANDARD BOLTS

Thread Size	Grade	Torque
5/16.....	5.....	13 ft./lb.
3/8.....	5.....	23 ft./lb.
7/16.....	5.....	37 ft./lb.
1/2.....	5.....	56 ft./lb.
5/8.....	5.....	150 ft./lb.

### METRIC BOLTS

Thread Size	Grade	Plated / Unplated
8mm-1.0 .....	8.8 .....	20 ft./lb. 18 ft./lb.
8mm-1.25 .....	8.8 .....	19 ft./lb. 18 ft./lb.
10mm-1.25 .....	8.8 .....	38 ft./lb. 36 ft./lb.
10mm-1.5 .....	8.8 .....	37 ft./lb. 35 ft./lb.

### METRIC BOLTS

Thread Size	Grade	Plated / Unplated
12mm-1.25 .....	8.8 .....	70 ft./lb. 65 ft./lb.
12mm-1.5 .....	8.8 .....	66 ft./lb. 61 ft./lb.
12mm-1.75 .....	8.8 .....	65 ft./lb. 60 ft./lb.
14mm-2.0 .....	8.8 .....	104 ft./lb. 97 ft./lb.