



# BASEPLATE KIT INSTALLATION INSTRUCTIONS

**KIT# 4412-3**

06/11/12  
KS

ROADMASTER, Inc. 6110 NE 127th Ave. Vancouver, WA 98682 360-896-0407 fax 360-735-9300 www.roadmasterinc.com

*Important*  
*Note: this bracket will not accommodate the Guardian rock shield, some models of the Tow Defender, Stowaway or the StowMaster and StowMaster All Terrain tow bars.*

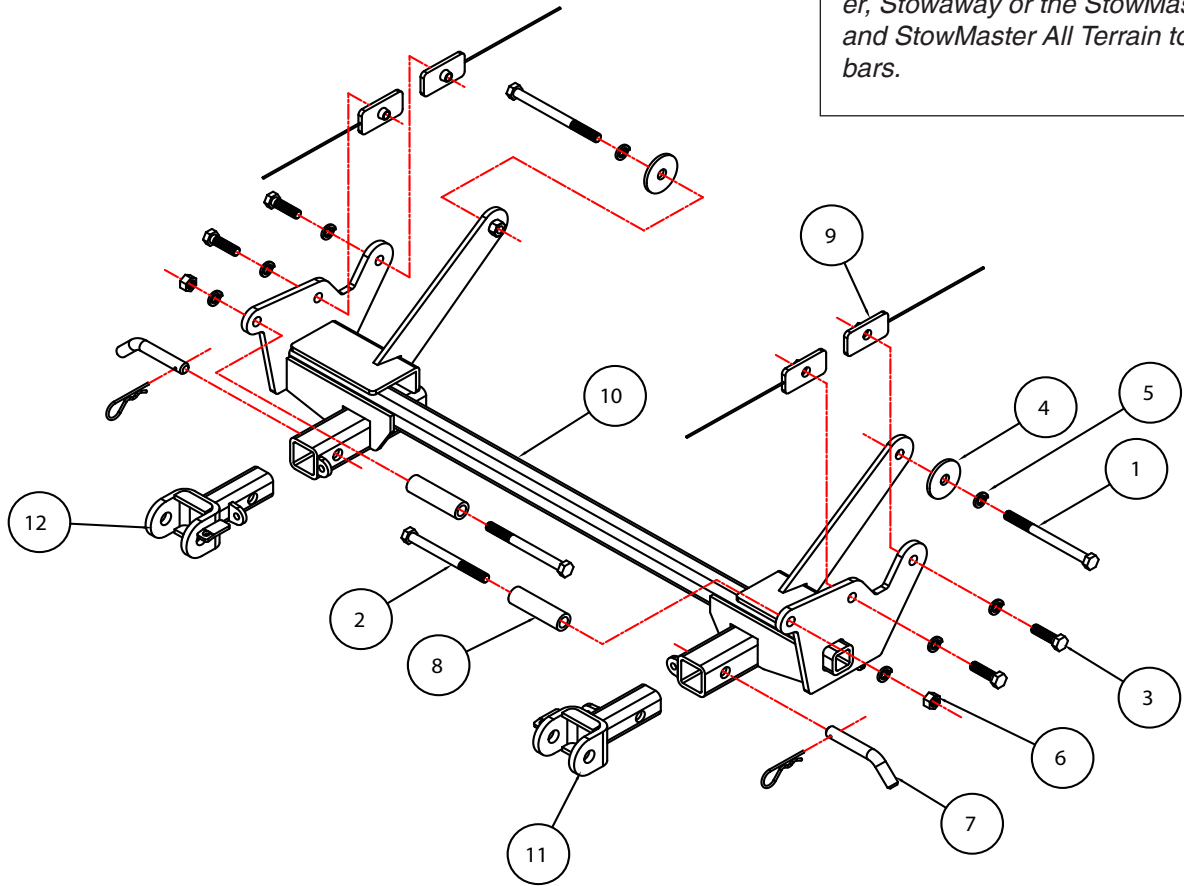

ITEM	QTY	NAME	MATERIAL
1	2	1/2" x 6" BOLT	350109-00
2	2	1/2" x 5 1/2" BOLT	350108-00
3	4	1/2" x 1 3/4" BOLT	350096-00
4	2	1/2" PLATE WASHER	350354-00
5	8	1/2" LOCK WASHER	350309-00
6	2	1/2" HEX NUT	350258-00
7	2	5/8" DRAW PIN W/ CLIP	357035-00
8	2	1" O.D. x 0.188 WALL x 3 9/16" PIPE SPACER	A-002432
9	4	1/4" x 1 1/2" x 3" THREADED BACKING PLATE W/ ROD	C-001301
10	1	MAIN RECEIVER	C-001530
11	1	DRIVER SIDE ARM	C-001476
12	1	PASSENGER SIDE ARM	C-001477

ROADMASTER, INC.



# BASEPLATE KIT INSTALLATION INSTRUCTIONS

**KIT# 4412-3**

06/11/12  
KS

ROADMASTER, Inc. 6110 NE 127th Ave. Vancouver, WA 98682 360-896-0407 fax 360-735-9300 www.roadmasterinc.com

This bracket kit is one of our MX series, which allows the visible front portion of the brackets to be easily removed (Fig.A and Fig.B). The kit consists of a main receiver brace, two removable front braces and a hardware pack.

The main receiver brace mounts to the frame rails and the removable front braces insert into the receivers on each side and are secured with draw pins.

Before starting the installation, lay out the kit components in order, as they will be used. This will give you a visual idea of how the components work, and will also confirm that everything is present and accounted for.



**IMPORTANT:** All baseplates **must** be assembled with all the bolts left loose for final adjustment and positioning (before tightening) unless otherwise instructed. All bolts **must** be torqued for proper strength. If more than one bolt is used per fastening point, the diagram may only show one. Use flat washers over all slotted holes and lock washers on all fasteners.

## WARNING

Failure to heed these warnings or follow the installation instructions may result in a voided warranty, loss of towed vehicle, personal injury or death.

- Do not weld or modify this baseplate or its components. Welding or modification will void the warranty.
- Do not use this document as a basis to design/fabricate a baseplate, as it may not show all parts or structural components.
- We strongly recommend professional installation.
- If the towed vehicle has been in an accident, it must be properly repaired before attaching the baseplate. Do not install the baseplate if any structural frame damage is found.
- The installer must use all bolts and parts supplied. If running changes were made by the vehicle manufacturer after this kit was designed, some bolts or other fasteners may no longer be the correct size. It is the installer's responsibility to verify this kit is securely fastened to the vehicle.
- Use Loctite® Red on all bolts used to secure this baseplate. Torque all bolts to the specifications found at the end of these instructions. Do not over-torque the bolts or failure may occur.
- The installer must inspect the baseplate to ensure adequate clearance, particularly around hoses, air conditioner lines, radiators, etc. or non-warranty failure may result.
- Roadmaster manufactures many styles of baseplates. If your baseplate has removable arms, they must be removed before driving the vehicle, unless the arms can be pinned or padlocked in place. If not secured, the arms could vibrate out.
- Some motorhome chassis have such a tight turning radius that you can damage your motorhome, towed vehicle, tow bar or baseplate while turning sharply. Before getting on the road, test your turning radius in an empty parking lot. Turning too sharply could result in non-warranty damage to your towing system, motorhome and/or towed vehicle.
- Do not back up with the towed vehicle attached or non-warranty damage will occur to your towing system or vehicles.
- The safety cables must connect the towing vehicle to the towed vehicle frame to frame, with the cables crossed, with enough slack for sharp turns. See cable instructions for proper routing. Failure to do so will result in non-warranty damage and/or the loss of the towed vehicle.
- This kit is designed for use with ROADMASTER tow bars and ROADMASTER adapters only. Using this kit with other brands, without an approved ROADMASTER adapter, may result in non-warranty damage or injury.
- Receiver extensions and out-of-level towing situations of 3 inches or more. This can cause the system to swing much higher and lower, causing excessive strain on the tow bar, baseplate and frame. That can cause the towing system to fail, causing property damage, personal injury or even death. If you must use a receiver extension or drop hitch to tow, it will reduce your receiver's weight capacity by 1/3 to avoid damaging your system. Never use more than one extension and/or drop hitch, as this will void your warranty.
- Every 3,000 miles, the owner must inspect all mounting points for cracks or fatigue, and check the fasteners for proper torque, according to the bolt torque requirements chart on the last page of these instructions.
- The owner must follow the vehicle manufacturer's instructions to prepare the vehicle for towing. Failure to do so may cause severe damage to the vehicle.
- This baseplate is only warranted for the original installation. Installing a used baseplate on another vehicle is not recommended and will void the warranty.



# BASEPLATE KIT INSTALLATION INSTRUCTIONS

**KIT# 4412-3**

06/11/12  
KS

ROADMASTER, Inc. 6110 NE 127th Ave. Vancouver, WA 98682 360-896-0407 fax 360-735-9300 www.roadmasterinc.com



1. **Important:** please use all supplied bolts and parts and read all instructions carefully before beginning this installation. The majority of questions you may have can be answered within the text, and proper installation will ensure safe and secure travel. Now, begin the installation. *Note:* some 250 and 350 models are equipped with an extra guard bracket mounted to the end of the subframe on each side. If this is the case, on each side, remove the guard bracket by removing two 18mm (head) bolts on either side of the subframe (Fig.C – passenger side, inside guard bracket bolts). Now, temporarily lower the sway bar by removing the four 15mm bushing clamp nuts, two per side (Fig.D).

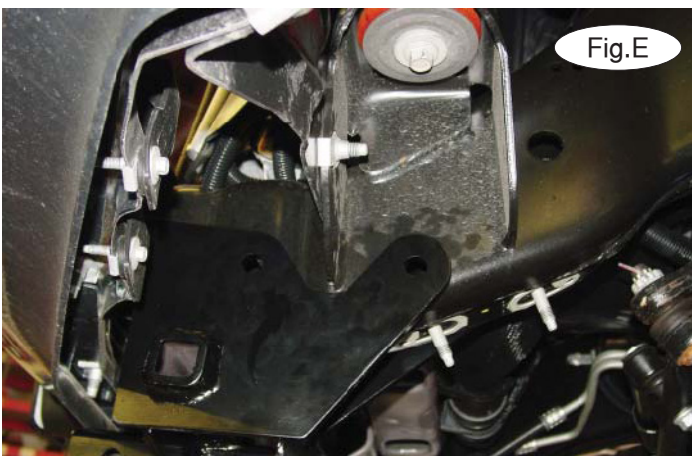

2. Next, slide the main receiver brace over the bottom of the frame (Fig.E). Using the  $\frac{1}{2}$ " x 6" bolt and plate washer, bolt through the existing upper rear hole in the frame rail and into the weld nut in the upper rear of the main receiver brace (Fig.F). Repeat for the other side.

3. Working on one side at a time, place one of the 1" x 3-9/16" spacers inside the end of the frame rail (Fig.G). Then, bolt through the frame rail, pipe spacer and main receiver brace finish with a lock washer and nut (Fig.H).





# BASEPLATE KIT INSTALLATION INSTRUCTIONS

**KIT# 4412-3**

06/11/12  
KS

ROADMASTER, Inc. 6110 NE 127th Ave. Vancouver, WA 98682 360-896-0407 fax 360-735-9300 www.roadmasterinc.com



4. Place the 1/4" x 1 1/2" x 3" backing plate with weld nut and attached wire inside the frame (Fig.I). Bolt through the third hole back and into the backing plate with the weld nut, using the 1/2" x 1 3/4" bolt and lock washer. Repeat for the second hole back (Fig.J).

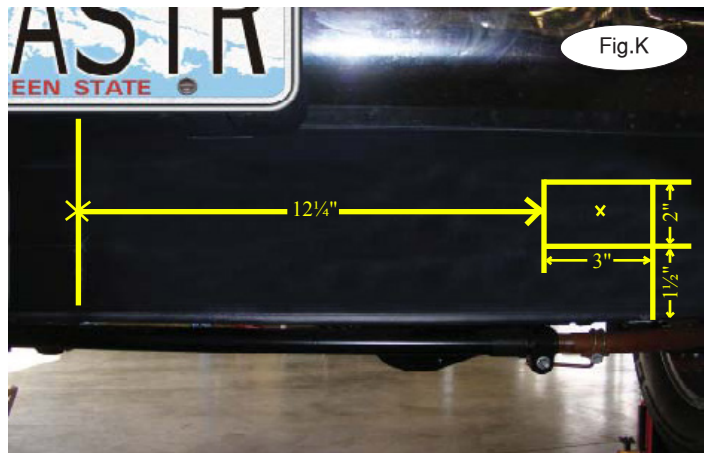
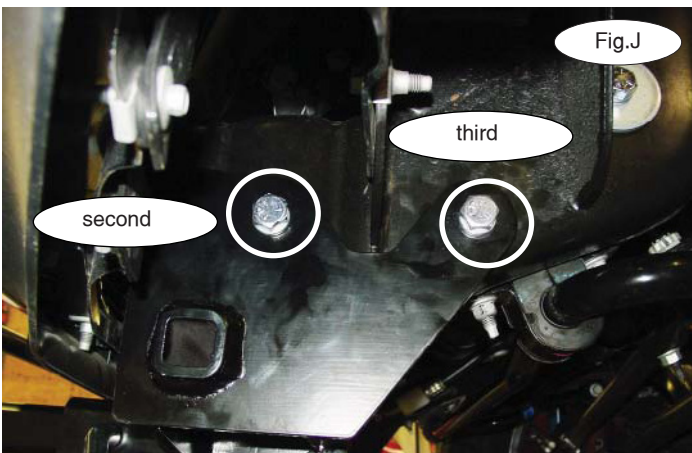

- Using a pair of pliers, break off the wire attached to the backing plate.
- Repeat steps 3 through 5 for the other side of the vehicle, then torque all the bolts to the bolt torque requirements at the end of these instructions. Reattach the sway bar.
- Depending on the trim package, some vehicles have a larger front air dam. This will need to be trimmed. Measurements in Figure K are used with the center point directly in line with the license plate holder. Once the measurements are laid out as shown, drill a pilot hole in the center of each square to verify alignment, and then trim the air dam to allow access for the main receiver brace.
- Insert the removable front bracket arms into the front receiver braces, and secure them in place with the supplied 5/8" draw pins and spring pins. Attach the ends of the safety cables to the main receiver brace.

## BOLT TORQUE REQUIREMENTS

Note: The torque values represented below are intended as general guidelines. Torque requirements for specific applications may vary. Roadmaster does not warrant this information to be accurate for all applications and disclaims all liability for any claims or damages which may result from its use.

STANDARD BOLTS			METRIC BOLTS			METRIC BOLTS		
Thread Size	Grade	Torque	Thread Size	Grade	Plated / Unplated	Thread Size	Grade	Plated / Unplated
5/16	5	13 ft./lb.	8mm-1.0	8.8	20 ft./lb. 18 ft./lb.	12mm-1.25	8.8	70 ft./lb. 65 ft./lb.
3/8	5	23 ft./lb.	8mm-1.25	8.8	19 ft./lb. 18 ft./lb.	12mm-1.5	8.8	66 ft./lb. 61 ft./lb.
7/16	5	37 ft./lb.	10mm-1.25	8.8	38 ft./lb. 36 ft./lb.	12mm-1.75	8.8	65 ft./lb. 60 ft./lb.
1/2	5	56 ft./lb.	10mm-1.5	8.8	37 ft./lb. 35 ft./lb.	14mm-2.0	8.8	104 ft./lb. 97 ft./lb.
5/8	5	150 ft./lb.						

All illustrations and specifications contained herein are based on the latest information available at the time of publication approval. ROADMASTER, INC. reserves the right to make changes at any time without notice in material, specification and models or to discontinue models.