



BASEPLATE KIT INSTALLATION INSTRUCTIONS

KIT# 4420-1

11/09/12
KS

ROADMASTER, Inc. 6110 NE 127th Ave. Vancouver, WA 98682 360-896-0407 fax 360-735-9300 www.roadmasterinc.com

ROADMASTER, INC.

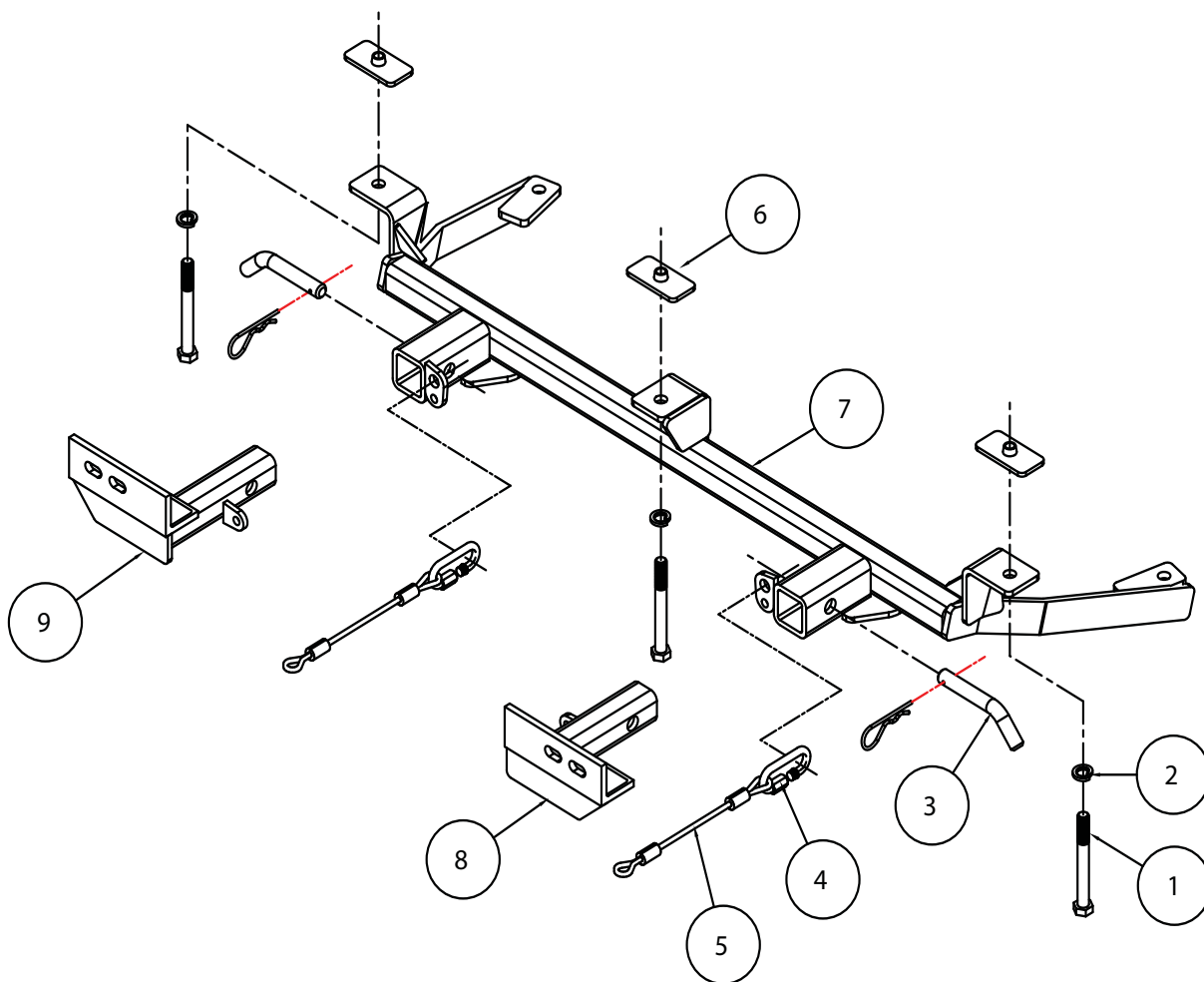

ITEM	QTY	NAME	MATERIAL
1	3	1/2" x 4 1/2" BOLT	350106-00
2	3	1/2" LOCK WASHER	350309-00
3	2	DRAW PIN	357035-00
4	2	QUICK LINK	200008-00
5	2	SAFETY CABLE 8"	650646-08
6	3	1 1/2" x 3" THREADED BACKING PLATE	A-003079
7	1	MAIN RECEIVER	C-001849
8	1	DRIVER SIDE ARM	C-001850
9	1	PASSENGER SIDE ARM	C-001851
10	1	3/4" x 12" SPLIT LOOM	300089-75



BASEPLATE KIT INSTALLATION INSTRUCTIONS

KIT# 4420-1

11/09/12
KS

ROADMASTER, Inc. 6110 NE 127th Ave. Vancouver, WA 98682 360-896-0407 fax 360-735-9300 www.roadmasterinc.com

This bracket kit is one of our XL series, which allows the visible front portion of the brackets to be easily removed (Fig.A and Fig.B). The kit consists of the main receiver brace, removable front braces and a hardware pack.

The main receiver brace mounts to the front frame and bumper core on each side. The removable front braces insert into the receivers on each side and are secured with draw pins.

Before starting the installation, lay out the kit components in order, as they will be used. This will give you a visual idea of how the components work, and will also confirm that everything is present and accounted for.



IMPORTANT: All baseplates **must** be assembled with all the bolts left loose for final adjustment and positioning (before tightening) unless otherwise instructed. All bolts **must** be torqued for proper strength. If more than one bolt is used per fastening point, the diagram may only show one. Use flat washers over all slotted holes and lock washers on all fasteners.

WARNING

Failure to heed these warnings or follow the installation instructions may result in a voided warranty, loss of towed vehicle, personal injury or death.

- Do not weld or modify this baseplate or its components. Welding or modification will void the warranty.
- Do not use this document as a basis to design/fabricate a baseplate, as it may not show all parts or structural components.
- We strongly recommend professional installation.
- If the towed vehicle has been in an accident, it must be properly repaired before attaching the baseplate. Do not install the baseplate if any structural frame damage is found.
- The installer must use all bolts and parts supplied. If running changes were made by the vehicle manufacturer after this kit was designed, some bolts or other fasteners may no longer be the correct size. It is the installer's responsibility to verify this kit is securely fastened to the vehicle.
- Use Loctite® Red on all bolts used to secure this baseplate. Torque all bolts to the specifications found at the end of these instructions. Do not over-torque the bolts or failure may occur.
- The installer must inspect the baseplate to ensure adequate clearance, particularly around hoses, air conditioner lines, radiators, etc. or non-warranty failure may result.
- Roadmaster manufactures many styles of baseplates. If your baseplate has removable arms, they must be removed before driving the vehicle, unless the arms can be pinned or padlocked in place. If not secured, the arms could vibrate out.
- Some motorhome chassis have such a tight turning radius that you can damage your motorhome, towed vehicle, tow bar or baseplate while turning sharply. Before getting on the road, test your turning radius in an empty parking lot. Turning too sharply could result in non-warranty damage to your towing system, motorhome and/or towed vehicle.
- Do not back up with the towed vehicle attached or non-warranty damage will occur to your towing system or vehicles.
- The safety cables must connect the towing vehicle to the towed vehicle frame to frame, with the cables crossed, with enough slack for sharp turns. See cable instructions for proper routing. Failure to do so will result in non-warranty damage and/or the loss of the towed vehicle.
- This kit is designed for use with ROADMASTER tow bars and ROADMASTER adapters only. Using this kit with other brands, without an approved ROADMASTER adapter, may result in non-warranty damage or injury.
- Receiver extensions and out-of-level towing situations of 3 inches or more. This can cause the system to swing much higher and lower, causing excessive strain on the tow bar, baseplate and frame. That can cause the towing system to fail, causing property damage, personal injury or even death. If you must use a receiver extension or drop hitch to tow, it will reduce your receiver's weight capacity by 1/3 to avoid damaging your system. Never use more than one extension and/or drop hitch, as this will void your warranty.
- Every 3,000 miles, the owner must inspect all mounting points for cracks or fatigue, and check the fasteners for proper torque, according to the bolt torque requirements chart on the last page of these instructions.
- The owner must follow the vehicle manufacturer's instructions to prepare the vehicle for towing. Failure to do so may cause severe damage to the vehicle.
- This baseplate is only warranted for the original installation. Installing a used baseplate on another vehicle is not recommended and will void the warranty.



INSTALLATION

ROADMASTER, Inc. 6110 NE 127th Ave. Vancouver, WA 98682 360-896-0407 fax 360-735-9300 www.roadmasterinc.com



1. **Important:** please use all supplied bolts and parts and read all instructions carefully before beginning this installation. The majority of questions you may have can be answered within the text, and proper installation will ensure safe and secure travel. Now, begin the installation. For 2011 Lincoln MKZ Hybrid models: see the supplemental instructions found at the end of this document. For all other models: remove six plastic fasteners and four screws attaching the upper fascia to the core support (Fig.C).

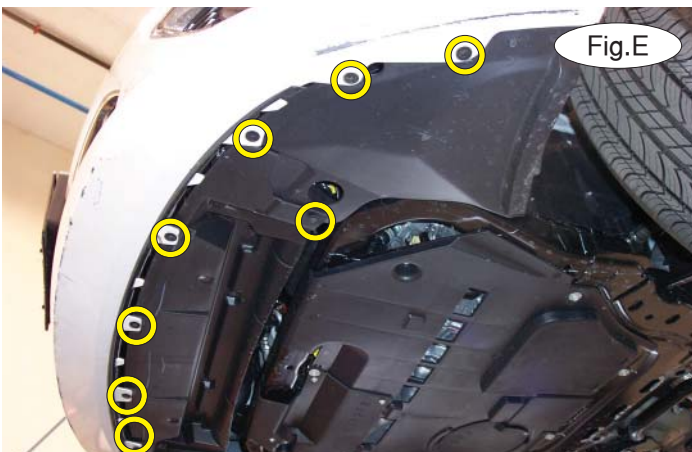

2. On each side, remove three plastic fasteners attaching the fender liner to the fascia (Fig.D).
3. Remove thirteen 7mm screws attaching the fascia to the splash panel (Fig.E – passenger side). *Note:* there are 11 screws across the front and two in the middle.
4. Pull back the fender liner and disconnect the marker lights and fog lights, if the vehicle is so equipped (Fig.F).
5. Pull out and forward to remove the fascia (Fig.G).





BASEPLATE KIT INSTALLATION INSTRUCTIONS

KIT# 4420-1

11/09/12
KS

ROADMASTER, Inc. 6110 NE 127th Ave. Vancouver, WA 98682 360-896-0407 fax 360-735-9300 www.roadmasterinc.com



6. Temporarily remove the shock absorption pad by pressing down to release the eight clips (Fig.H).

7. Using the supplied $\frac{3}{4}$ " x 12" wiring loom, cover the oil cooling line to protect it from the main receiver brace (Fig.I).

Note: due to manufacturing variances, the cooling line may rest on top of the main receiver brace once it's installed.

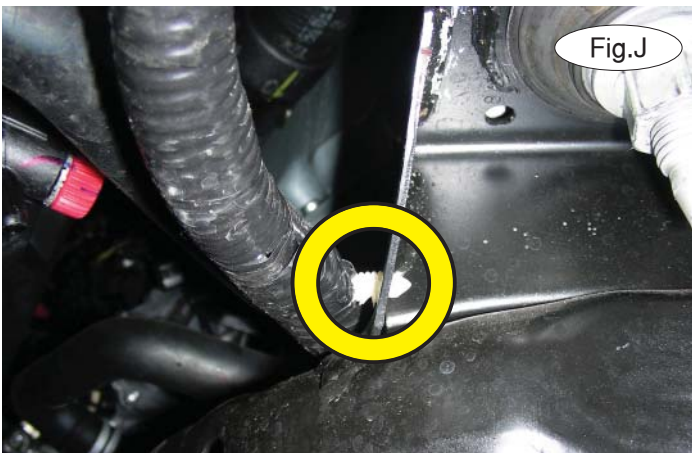

8. Now, remove one plastic fastener attaching the wiring harness to the subframe (Fig.J).

9. Push the wiring harness slightly into the engine compartment near the oil cooling line to allow clearance for the main receiver brace (Fig.K).

10. Use a floor jack to support the subframe of the vehicle and remove two 21mm subframe nuts and flat washers (Fig.L).





BASEPLATE KIT INSTALLATION INSTRUCTIONS

KIT# 4420-1

11/09/12
KS

ROADMASTER, Inc. 6110 NE 127th Ave. Vancouver, WA 98682 360-896-0407 fax 360-735-9300 www.roadmasterinc.com



11. Place the rear mounts of the main receiver brace over the studs you exposed in the previous step, and finish with the 21mm subframe nuts and lock washers (Fig.M). *Note:* use thread lock on the nuts.

12. Clamp the center mounting point of the main receiver brace to the bumper core (Fig.N). Torque the two 21mm subframe nuts to 104 ft./lbs.

13. On each side, using the pre-existing upper holes in the main receiver brace as a template, drill a 1/2" hole through the bottom and top layers of the bumper core (Fig.O). If you experience difficulty in drilling due to the hard composition of the bumper core, drill a pilot hole first. Make certain you use a sharp drill bit. *Note:* use a piece of metal behind the drill to protect engine components.



14. Working on the passenger side end mounting point, place a 1/2" lock washer over a 1/2" x 4 1/2" bolt, and place a 3/16" x 1 1/2" x 3" threaded backing plate on top of the bumper core. Bolt through the main receiver brace and bumper core and into the nutted backing plate (Fig.P).

15. Repeat step 11 on the driver's side end mounting point, then remove the clamp. Using the pre-existing hole in the main receiver brace as a template, drill a 1/2" hole through the center mounting point and through the bumper core.

16. Place a 1/2" lock washer over a 1/2" x 4 1/2" bolt, and place a 3/16" x 1 1/2" x 3" threaded backing plate on top of the bumper core above the center mounting point. Bolt through the main receiver brace and bumper core and into the nutted backing plate (Fig.Q).

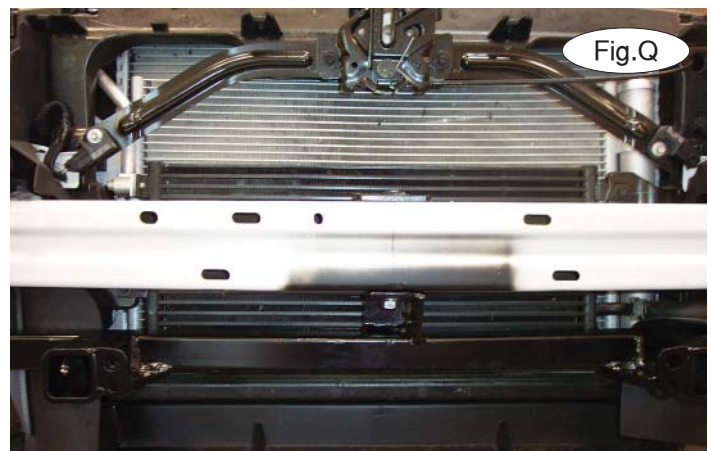



BASEPLATE KIT INSTALLATION INSTRUCTIONS

KIT# 4420-1

11/09/12
KS

ROADMASTER, Inc. 6110 NE 127th Ave. Vancouver, WA 98682 360-896-0407 fax 360-735-9300 www.roadmasterinc.com

Fig.R



Fig.S

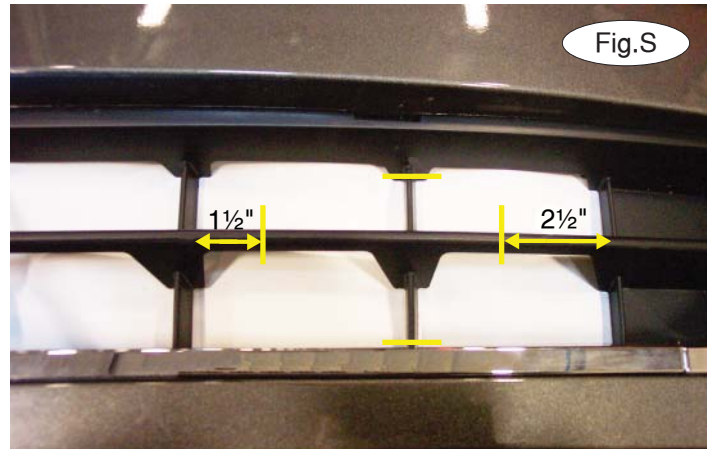

17. Trim the shock absorption pad using the yellow lines in Figure R as a guide for trimming both sides of the pad, then reinstall it by reversing step 6.

18. **For Lincoln MKZ Hybrid models:** trim the fascia, measuring over 1½" from the first vertical rib, and 2½" over from the side piece. Use the yellow lines and measurements in Figure S as a guide for trimming. **For all other models:** trim the fascia using the yellow lines in Figure T as a guide for trimming.

Fig.T



Fig.U



19. Torque all remaining bolts to the bolt torque requirements found at the end of this document.
20. Reassemble the fascia by reversing steps 1 through 5.
21. Insert the removable front bracket arms into the front receiver braces, and secure them in place with the supplied 5/8" draw pins and spring pins.
22. Attach the 8" safety cables with the cable connectors (Q-Links) to the front of the receiver braces (Fig.U).
23. Attach the ends of the safety cables to the tow vehicle's safety cables.
24. Install the tow bar to the mounting bracket according to the manufacturer's instructions.

Note: if the bracket is so equipped, the holes in the alignment tabs which are welded to the arms and main receiver braces are for padlocks only. Under no circumstances should you bolt the alignment tabs together. Bolting the alignment tabs together may result in non-warranty damage to the bracket.



BASEPLATE KIT INSTALLATION INSTRUCTIONS

KIT# 4420-1

11/09/12
KS

ROADMASTER, Inc. 6110 NE 127th Ave. Vancouver, WA 98682 360-896-0407 fax 360-735-9300 www.roadmasterinc.com

BOLT TORQUE REQUIREMENTS

Note: The torque values represented below are intended as general guidelines. Torque requirements for specific applications may vary. Roadmaster does not warrant this information to be accurate for all applications and disclaims all liability for any claims or damages which may result from its use.

STANDARD BOLTS

Thread Size	Grade	Torque
5/16.....	5.....	13 ft./lb.
3/8.....	5.....	23 ft./lb.
7/16.....	5.....	37 ft./lb.
1/2.....	5.....	56 ft./lb.
5/8.....	5.....	150 ft./lb.

METRIC BOLTS

Thread Size	Grade	Plated / Unplated
8mm-1.0	8.8	20 ft./lb. 18 ft./lb.
8mm-1.25	8.8	19 ft./lb. 18 ft./lb.
10mm-1.25	8.8	38 ft./lb. 36 ft./lb.
10mm-1.5	8.8	37 ft./lb. 35 ft./lb.

METRIC BOLTS

Thread Size	Grade	Plated / Unplated
12mm-1.25	8.8	70 ft./lb. 65 ft./lb.
12mm-1.5	8.8	66 ft./lb. 61 ft./lb.
12mm-1.75	8.8	65 ft./lb. 60 ft./lb.
14mm-2.0	8.8	104 ft./lb. 97 ft./lb.

All illustrations and specifications contained herein are based on the latest information available at the time of publication approval. ROADMASTER, INC. reserves the right to make changes at any time without notice in material, specification and models or to discontinue models.



BASEPLATE KIT INSTALLATION INSTRUCTIONS

KIT# 4420-1

11/09/12
KS

ROADMASTER, Inc. 6110 NE 127th Ave. Vancouver, WA 98682 360-896-0407 fax 360-735-9300 www.roadmasterinc.com

Supplemental Instructions for 2011 Lincoln MKZ Hybrid Fascia Removal

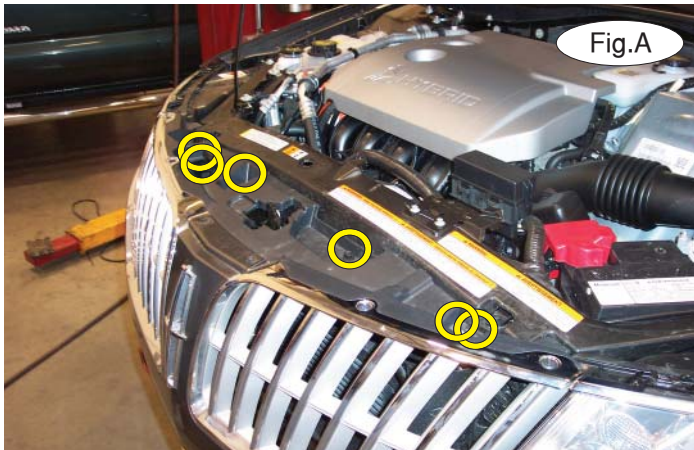

1. Remove four 10mm (head) bolts and two plastic fasteners attaching the top of the fascia to the radiator support (Fig.A).
2. On each side, remove three plastic fasteners attaching the fender liner to the fascia (Fig.B).
3. On each side, remove three 7mm (head) bolts and two plastic fasteners attaching the center splash shield to the fender liners and radiator support (Fig.C).

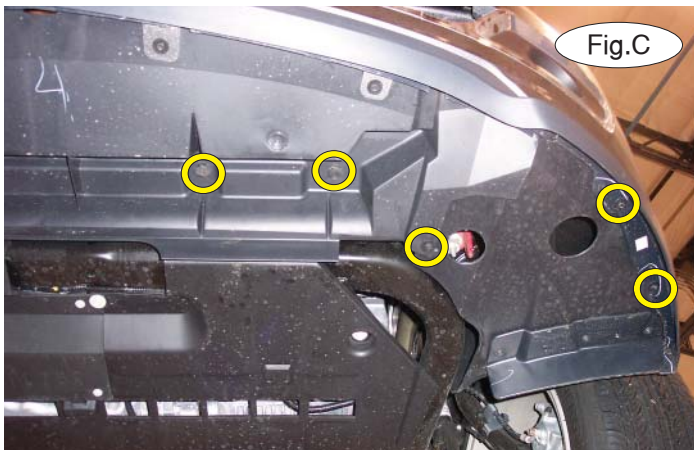

4. Pull back the fender liners and disconnect the fog lights (Fig.D).
 5. Pull out and forward on the corners of the fascia to remove (Fig.E).
- Now, return to step 6 in the regular instructions to finish the installation.

