



BASEPLATE KIT INSTALLATION INSTRUCTIONS

KIT# 492-1

11/2025
MS

ROADMASTER, Inc.

6110 NE 127th Ave.

Vancouver, WA 98682

360-896-0407

www.RoadmasterInc.com

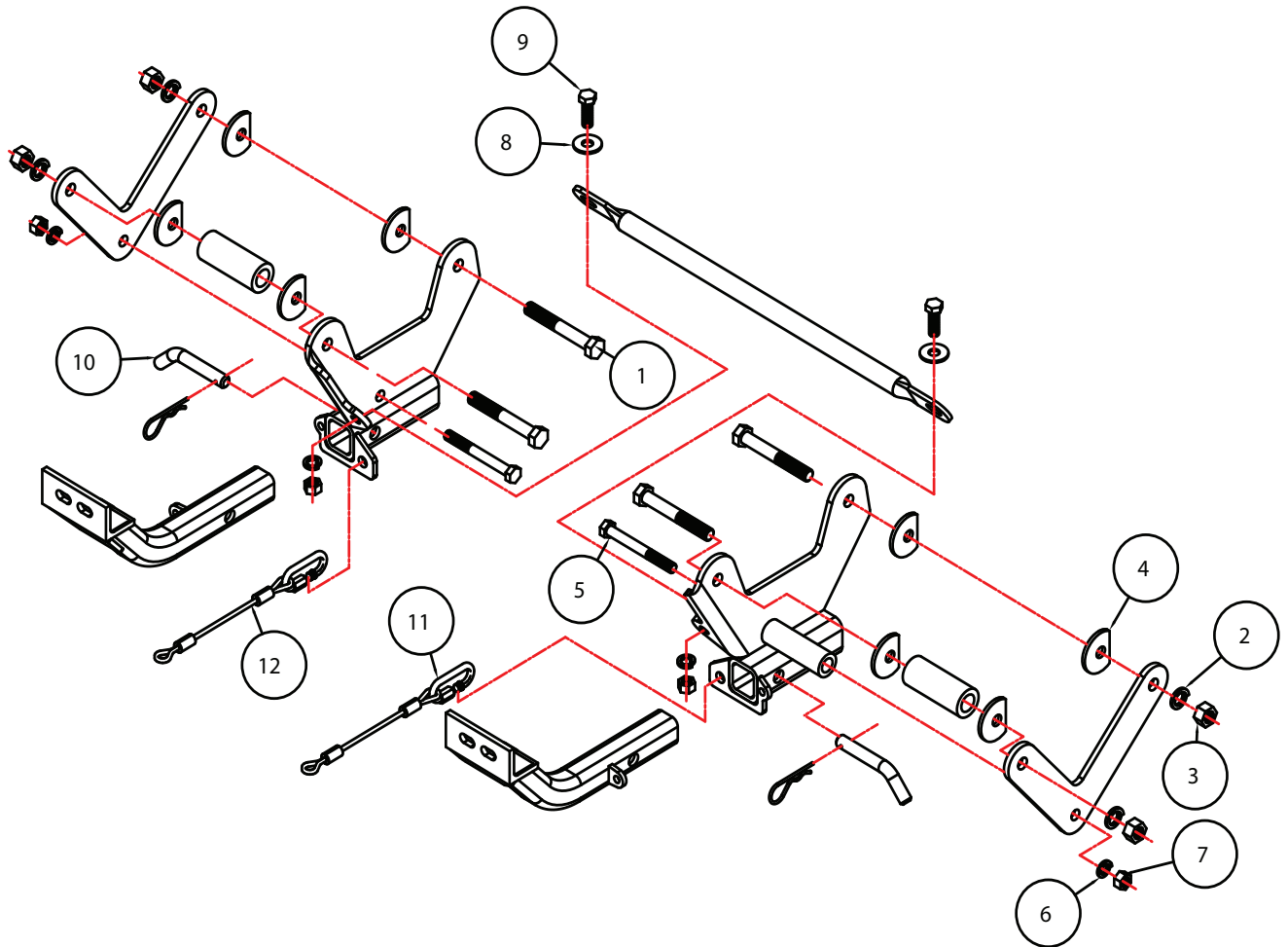

Item	Qty	Length	Width	Hardware	Part No.
1	4	5 1/2"	5/8"	BOLT	350161-00
2	4	5/8"		LOCK WASHER	350313-00
3	4	5/8"		NUT	350262-00
4	8	5/8"		CLIPPED PLATE WASHER	350352-00
5	2	5 1/2"	1/2"	BOLT	350108-00
6	4	1/2"		LOCKWASHER	350309-00
7	4	1/2"		NUT	350258-00
8	2	1/2"		FLAT WASHER	350308-20
9	2	1 1/2"	1/2"	BOLT	350095-00
10	2			DRAW PIN/SPRING PIN	357035-00
11	2			CONNECTORS	200008-00
12	2	10"		CABLES, 8,000 lb. rated	650648-10



BASEPLATE KIT INSTALLATION INSTRUCTIONS

KIT# 492-1

11/2025

MS

ROADMASTER, Inc.

6110 NE 127th Ave.

Vancouver, WA 98682

360-896-0407

www.RoadmasterInc.com

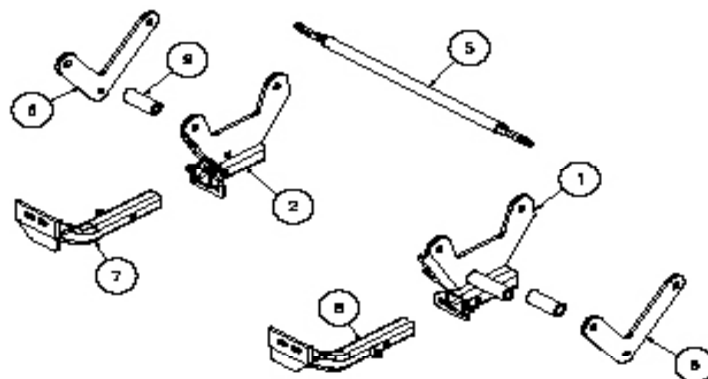

Item	Qty	Part No.	Assembly
1	1	C-000689	DRIVER SIDE RECEIVER BRACE WELDMENT
2	1	C-000690	PASSENGER SIDE RECEIVER BRACE WELDMENT
5	1	B-000477	CROSS BRACE
6	2	A-001170	BACKING PLATE
7	1	C-000692	PASSENGER SIDE ARM WELDMENT
8	1	C-000691	DRIVER SIDE ARM WELDMENT
9	2	A-001179	1 1/4"OD X 3 1/8" X .250 WALL TUBE

IMPORTANT: All baseplates **must** be assembled with all the bolts left loose for final adjustment and positioning (before tightening) unless otherwise instructed. All bolts **must** be torqued for proper strength. If more than one bolt is used per fastening point, the diagram may only show one. Use flat washers over all slotted holes and lock washers on all fasteners.

WARNING

Failure to heed these warnings or follow the installation instructions may result in a voided warranty, loss of towed vehicle, personal injury or death.

- Do not weld or modify this baseplate or its components. Welding or modification will void the warranty.
- Do not use this document as a basis to design/fabricate a baseplate, as it may not show all parts or structural components.
- We strongly recommend professional installation.
- If the towed vehicle has been in an accident, it must be properly repaired before attaching the baseplate. Do not install the baseplate if any structural frame damage is found.
- The installer must use all bolts and parts supplied. If running changes were made by the vehicle manufacturer after this kit was designed, some bolts or other fasteners may no longer be the correct size. It is the installer's responsibility to verify this kit is securely fastened to the vehicle.
- Use Threadlocker Red on all bolts used to secure this baseplate. Torque all bolts to the specifications found at the end of these instructions. Do not over-torque the bolts or failure may occur.
- The installer must inspect the baseplate to ensure adequate clearance, particularly around hoses, air conditioner lines, radiators, etc. or non-warranty failure may result.
- Roadmaster manufactures many styles of baseplates. If your baseplate has removable arms, they must be removed before driving the vehicle, unless the arms can be pinned or padlocked in place. If not secured, the arms could vibrate out.
- Some motorhome chassis have such a tight turning radius that you can damage your motorhome, towed vehicle, tow bar or baseplate while turning sharply. Before getting on the road, test your turning radius in an empty parking lot. Turning too sharply could result in non-warranty damage to your towing system, motorhome and/or towed vehicle.
- Do not back up with the towed vehicle attached or non-warranty damage will occur to your towing system or vehicles.
- The safety cables must connect the towing vehicle to the towed vehicle frame to frame, with the cables crossed, with enough slack for sharp turns. See cable instructions for proper routing. Failure to do so will result in non-warranty damage and/or the loss of the towed vehicle.
- This kit is designed for use with ROADMASTER tow bars and ROADMASTER adapters only. Using this kit with other brands, without an approved ROADMASTER adapter, may result in non-warranty damage or injury.
- Receiver extensions and out-of-level towing situations of 3" or more can cause the system to swing much higher and lower, causing excessive strain on the tow bar, baseplate and frame. That can cause the towing system to fail, causing property damage, personal injury or even death. If you must use a receiver extension or drop hitch to tow, it will reduce your receiver's the towing system's capacity by 1/3 to avoid damaging your system. Never use more than one extension and/or drop hitch, as this will void your warranty.
- Every 3,000 miles, the owner must inspect all mounting points for cracks or fatigue, and check the fasteners for proper torque, according to the bolt torque requirements chart on the last page of these instructions.
- The owner must check and follow the vehicle manufacturer's instructions to prepare the vehicle for towing. Failure to do so may cause severe damage to the vehicle.
- This baseplate is only warranted for the original installation. Installing a used baseplate on another vehicle is not recommended and will void the warranty.



BASEPLATE KIT INSTALLATION INSTRUCTIONS

KIT# 492-1

11/2025
MS

ROADMASTER, Inc.

6110 NE 127th Ave.

Vancouver, WA 98682

360-896-0407

www.RoadmasterInc.com

1. This bracket kit is one of our XL series, which allows you to remove the most visual portion of the bracket (Fig.A). The kit consists of two receiver braces, two front braces and a hardware pack. The receiver braces are designed to mount to the frame tubes on each side. Some units may require removal of the lower air dam or holes cut for the front braces to slide into the receivers. Layout the kit as illustrated, this will show you how it is assembled and assure the kit is complete.



1. Important: please use all supplied bolts and parts and

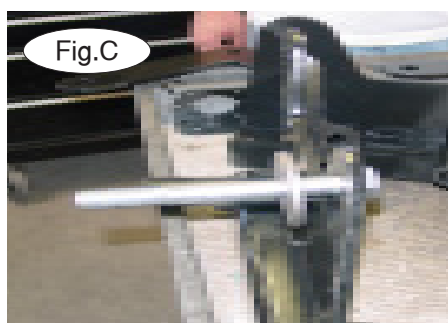

read all instructions carefully before beginning this installation. The majority of questions you may have can be answered within the text, and proper installation will ensure safe and secure travel. Now, begin the installation.

2. Working on one side at a time, select a receiver brace, one L shaped backing plate, one 5/8" x 5 1/2" bolt, two 5/8" clipped plate washers, a lock washer and nut. Insert the bolt in the rear mounting hole in the receiver brace (Fig.B) followed with one 5/8" plate washer (Fig.C).

3. Find an existing hole on the inside of the frame rail and mount the receiver brace to the frame rail with the bolt completely



through the frame (Fig.D). Follow with another 5/8" plate washer (Fig.E), the L shaped backing plate then a lock washer and nut (Fig.F).

4. Find another 5/8" x 5 1/2" bolt, two 5/8" clipped plate washers, a pipe spacer, lock washer and nut. Bolt through the



BASEPLATE KIT INSTALLATION INSTRUCTIONS

KIT# 492-1

11/2025

MS

ROADMASTER, Inc.

6110 NE 127th Ave.

Vancouver, WA 98682

360-896-0407

www.RoadmasterInc.com

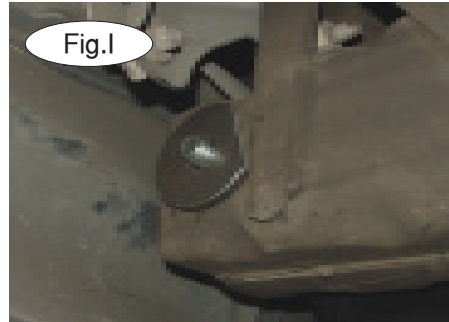

front mounting hole in the brace in the same manner as the two previous steps with the exception of installing the pipe spacer inside the front of the frame (Fig.G,H,I,J).

5. Bolt through the bottom of the receiver brace and the L shaped backing plate with a 1/2" x 5 1/2" bolt, lock washer and nut (Fig.K,L).

6. Repeat step 2 through 5 for the remaining side (Fig.M).

7. Mount the center brace between the two receiver braces with two 1/2" x 1 1/2" bolts, flat washers, lock washers and nuts (Fig.M,N).

8. Torque all mounting bolts to the specifications on the last page.

9. Insert the front brace into the receiver tubes and pin with 5/8" draw pins and 1/8" spring pins (Fig.O,P). *Note:* if vehicle has a additional small air dam, either remove or cut it for clearance.

10. Install the tow bar according to the manufacturer's instructions and torque all mounting bolts to the specifications at the end of these instructions.

11. Attach one end of the included 10" safety cables to the lower front hole in the side mounting plate on each side of the receiver brace with the included cable connectors. Connect the other end to the tow vehicle's safety cables and



BOLT TORQUE REQUIREMENTS

Note: The torque values represented below are intended as general guidelines. Torque requirements for specific applications may vary. Roadmaster does not warrant this information to be accurate for all applications and disclaims all liability for any claims or damages which may result from its use.

STANDARD BOLTS

Thread Size	Grade	Torque
5/16	5	13 ft./lb.
3/8	5	23 ft./lb.
7/16	5	37 ft./lb.
1/2	5	56 ft./lb.
5/8	5	150 ft./lb.

METRIC BOLTS

Thread Size	Grade	Plated / Unplated
8mm-1.0	8.8	20 ft./lb. 18 ft./lb.
8mm-1.25	8.8	19 ft./lb. 18 ft./lb.
10mm-1.25	8.8	38 ft./lb. 36 ft./lb.
10mm-1.5	8.8	37 ft./lb. 35 ft./lb.

METRIC BOLTS

Thread Size	Grade	Plated / Unplated
12mm-1.25	8.8	70 ft./lb. 65 ft./lb.
12mm-1.5	8.8	66 ft./lb. 61 ft./lb.
12mm-1.75	8.8	65 ft./lb. 60 ft./lb.
14mm-2.0	8.8	104 ft./lb. 97 ft./lb.