



BASEPLATE KIT INSTALLATION INSTRUCTIONS

KIT# 521195-4

06/23/16
KS

ROADMASTER, Inc. 6110 NE 127th Ave. Vancouver, WA 98682 360-896-0407 fax 360-735-9300 www.roadmasterinc.com

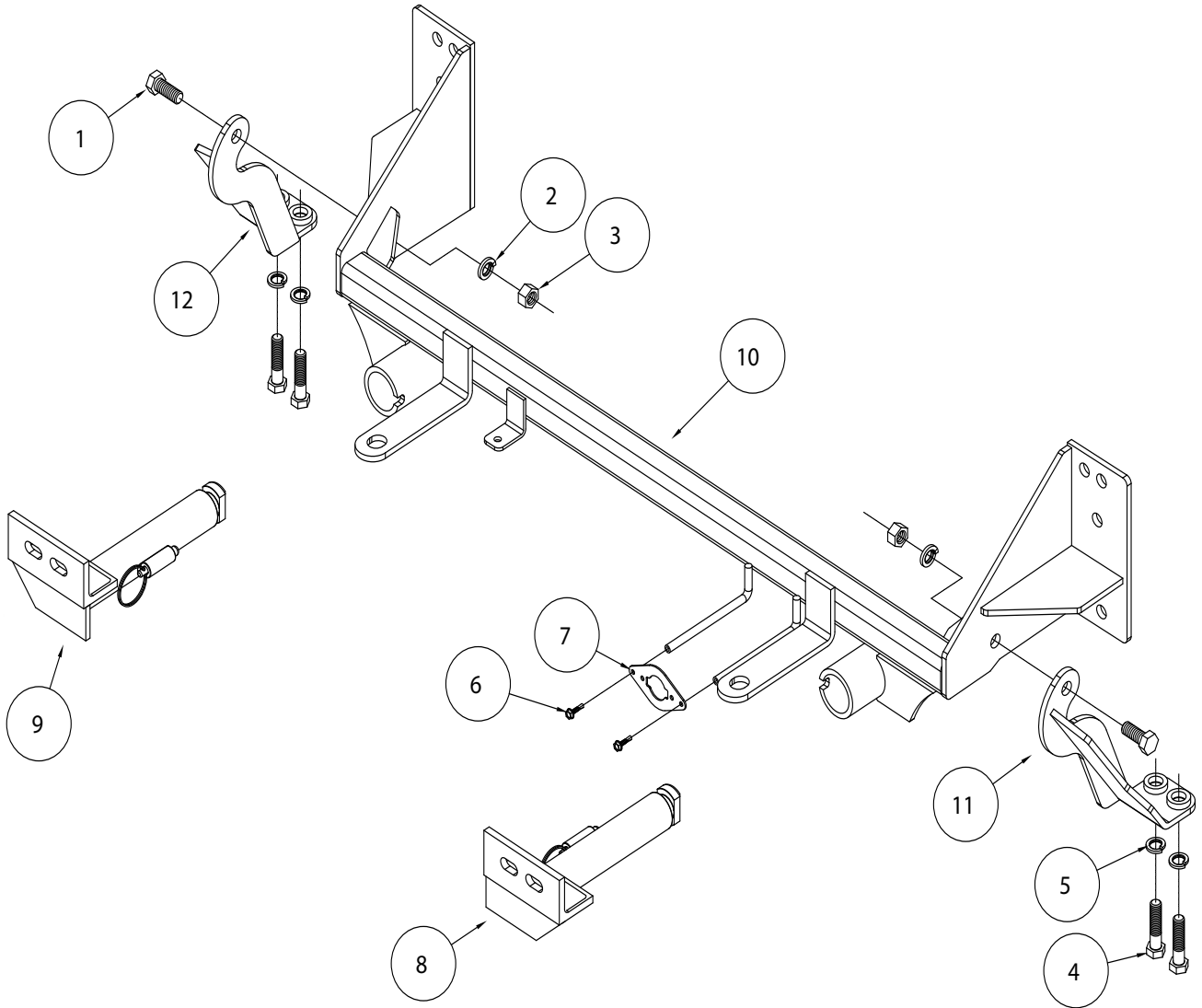

ITEM	QTY	NAME	PART #
1	2	1/2" x 1 1/4" BOLT	350094-00
2	2	1/2" LOCK WASHER	350309-00
3	2	1/2" HEX NUT	350258-00
4	4	12mm x 1.25 x 50mm	357005-00
5	4	12 LOCK WASHER	355725-00
6	2	#10 x 3/4" SELF DRILLING SCREW	350247-00
7	1	WIRE PLUG PLATE	A-003801
8	1	DRIVER SIDE ARM	C-002807
9	1	PASSENGER SIDE ARM	C-002808
10	1	MAIN RECEIVER	C-002809
11	1	DRIVER SIDE BRACE	C-002810
12	1	PASSENGER SIDE BRACE	C-002811
13	1	ZIPTIE	300140-8



BASEPLATE KIT INSTALLATION INSTRUCTIONS

KIT# 521195-4

06/23/16
KS

ROADMASTER, Inc. 6110 NE 127th Ave. Vancouver, WA 98682 360-896-0407 fax 360-735-9300 www.roadmasterinc.com

This is one of our EZ4 series brackets, which allows the visible front portion of the bracket to be easily removed from the front of the vehicle (Fig.A and Fig.B). The bracket consists of a main receiver brace, two lower braces, two removable front braces, and a hardware pack.

The main receiver brace mounts to the frame and the bumper core mounts. The removable front braces install in the main receiver brace.

Before starting the installation, lay out the kit components in order, as they will be used. This will give you a visual idea of how the components work, and will also confirm that everything is present and accounted for.



IMPORTANT: All baseplates **must** be assembled with all the bolts left loose for final adjustment and positioning (before tightening) unless otherwise instructed. All bolts **must** be torqued for proper strength. If more than one bolt is used per fastening point, the diagram may only show one. Use flat washers over all slotted holes and lock washers on all fasteners.

WARNING

Failure to heed these warnings or follow the installation instructions may result in a voided warranty, loss of towed vehicle, personal injury or death.

- Do not weld or modify this baseplate or its components. Welding or modification will void the warranty.
- Do not use this document as a basis to design/fabricate a baseplate, as it may not show all parts or structural components.
- We strongly recommend professional installation.
- If the towed vehicle has been in an accident, it must be properly repaired before attaching the baseplate. Do not install the baseplate if any structural frame damage is found.
- The installer must use all bolts and parts supplied. If running changes were made by the vehicle manufacturer after this kit was designed, some bolts or other fasteners may no longer be the correct size. It is the installer's responsibility to verify this kit is securely fastened to the vehicle.
- Use Loctite® Red on all bolts used to secure this baseplate. Torque all bolts to the specifications found at the end of these instructions. Do not over-torque the bolts or failure may occur.
- The installer must inspect the baseplate to ensure adequate clearance, particularly around hoses, air conditioner lines, radiators, etc. or non-warranty failure may result.
- Roadmaster manufactures many styles of baseplates. If your baseplate has removable arms, they must be removed before driving the vehicle, unless the arms can be pinned or padlocked in place. If not secured, the arms could vibrate out.
- Some motorhome chassis have such a tight turning radius that you can damage your motorhome, towed vehicle, tow bar or baseplate while turning sharply. Before getting on the road, test your turning radius in an empty parking lot. Turning too sharply could result in non-warranty damage to your towing system, motorhome and/or towed vehicle.
- Do not back up with the towed vehicle attached or non-warranty damage will occur to your towing system or vehicles.
- The safety cables must connect the towing vehicle to the towed vehicle frame to frame, with the cables crossed, with enough slack for sharp turns. See cable instructions for proper routing. Failure to do so will result in non-warranty damage and/or the loss of the towed vehicle.
- This kit is designed for use with ROADMASTER tow bars and ROADMASTER adapters only. Using this kit with other brands, without an approved ROADMASTER adapter, may result in non-warranty damage or injury.
- Receiver extensions and out-of-level towing situations of 3 inches or more. This can cause the system to swing much higher and lower, causing excessive strain on the tow bar, baseplate and frame. That can cause the towing system to fail, causing property damage, personal injury or even death. If you must use a receiver extension or drop hitch to tow, it will reduce your receiver's weight capacity by 1/3 to avoid damaging your system. Never use more than one extension and/or drop hitch, as this will void your warranty.
- Every 3,000 miles, the owner must inspect all mounting points for cracks or fatigue, and check the fasteners for proper torque, according to the bolt torque requirements chart on the last page of these instructions.
- The owner must follow the vehicle manufacturer's instructions to prepare the vehicle for towing. Failure to do so may cause severe damage to the vehicle.
- This baseplate is only warranted for the original installation. Installing a used baseplate on another vehicle is not recommended and will void the warranty.



BASEPLATE KIT INSTALLATION INSTRUCTIONS

KIT# 521195-4

06/23/16
KS

ROADMASTER, Inc. 6110 NE 127th Ave. Vancouver, WA 98682 360-896-0407 fax 360-735-9300 www.roadmasterinc.com

Instructions for Scion tC models

*Note: this bracket fits both Scion iM and tC models. For iM models, please see the second half of this instruction booklet.
For Scion tC instructions, follow the steps below.*

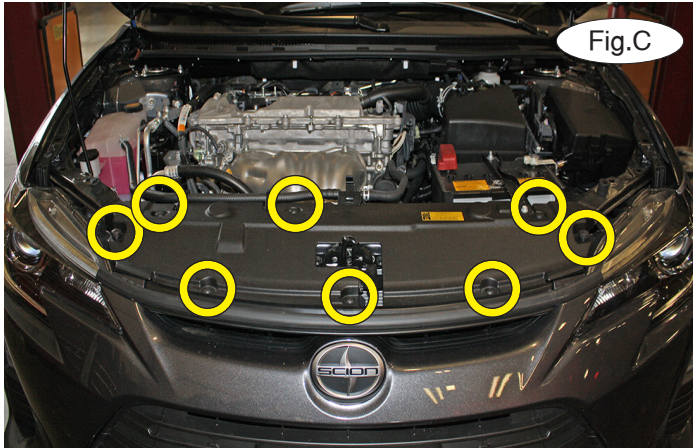

1. **Important:** please use all supplied bolts and parts and read all instructions carefully before beginning this installation. The majority of questions you may have can be answered within the text, and proper installation will ensure safe and secure travel. Now, begin the installation. Remove eight plastic fasteners attaching the radiator cover to the fascia and the core support (Fig.C). *Note:* the six center fasteners release by depressing the center button and the two outside fasteners must be pulled up on to be released.

2. Remove three plastic fasteners and two 10mm (head) bolts attaching the top of the fascia to the core support (Fig.D).

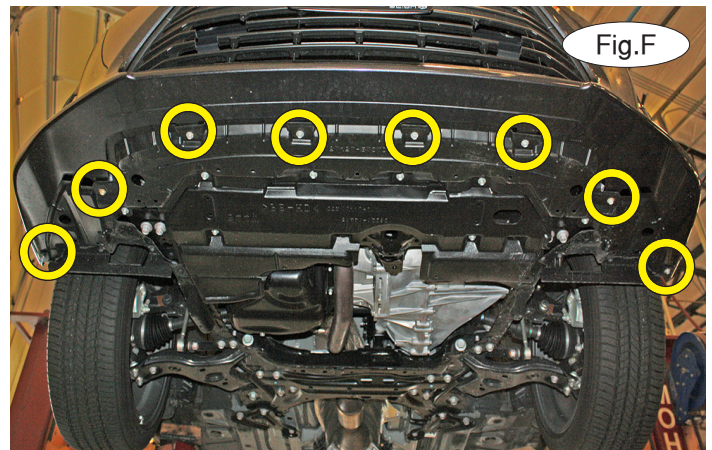

3. On each side, remove one 10mm screw and one pin fastener attaching the fender liner to the fascia (Fig.E – driver's side).

4. Remove eight 10mm screws attaching the bottom of the fascia to the splash shielding (Fig.F).

5. On each side, release the fender liner fastener from the fascia and pull the corner of the fascia off the alignment posts. Continue pulling out on the corner to release the locking strip. Figure G shows the directions you should pull for each section to remove the fascia. Disconnect the fog lights, if the vehicle is so equipped.





BASEPLATE KIT INSTALLATION INSTRUCTIONS

KIT# 521195-4

06/23/16
KS

ROADMASTER, Inc. 6110 NE 127th Ave. Vancouver, WA 98682 360-896-0407 fax 360-735-9300 www.roadmasterinc.com

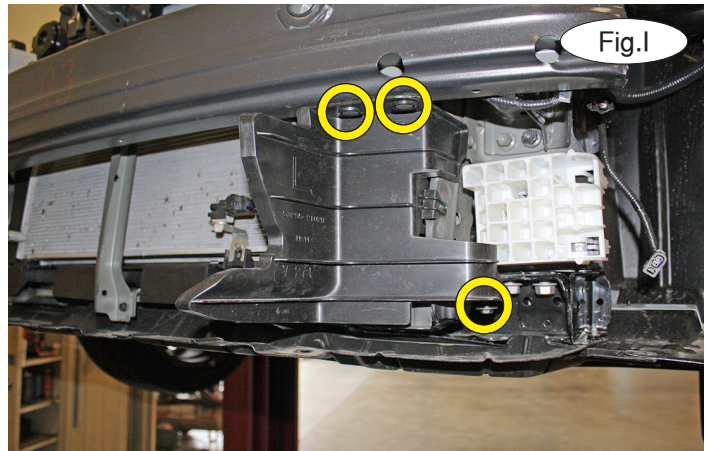
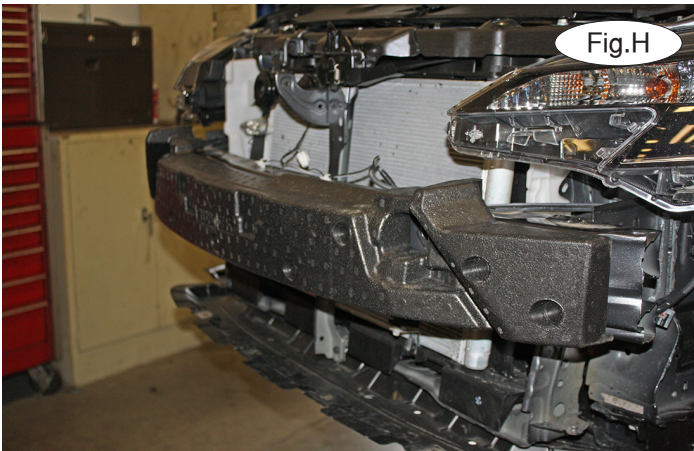

6. Remove the foam shock absorption pad (Fig.H). *Note:* it will not be replaced. Retain the foam shock absorption pad for replacement in case the bracket is ever removed.

7. On each side, remove the air dam by releasing the two plastic fasteners and one 10mm (head) screw located below the bumper core (Fig.I). *Note:* they will not be replaced. Retain the air dams for replacement in case the bracket is ever removed.

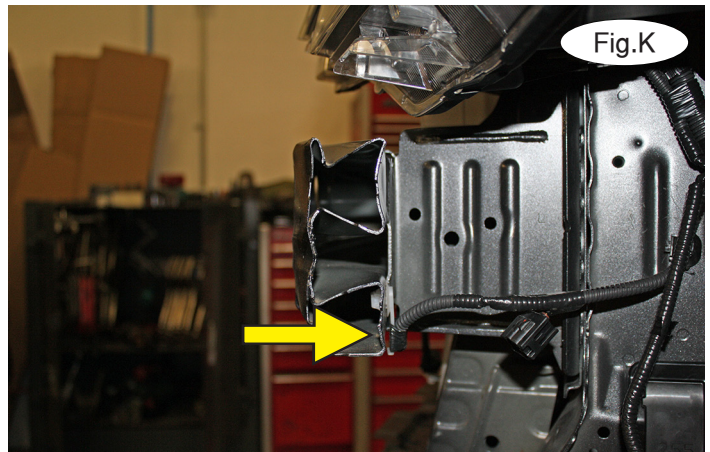
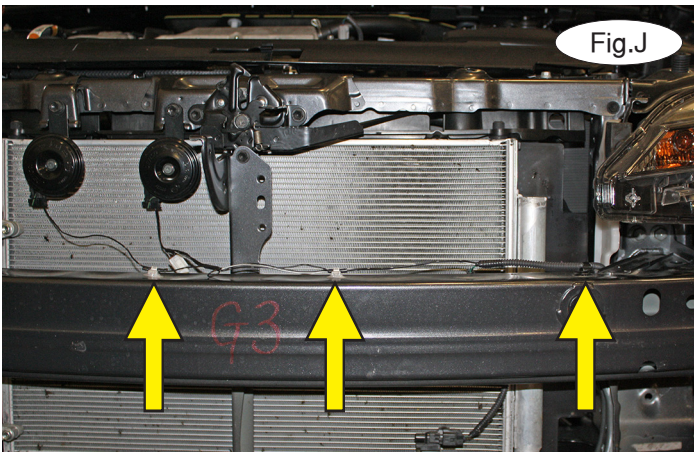

8. Remove four wiring loom mounts from the bumper core (Fig.J and Fig.K).

9. On the driver's side only, remove the plastic component (Fig.L). *Note:* it will not be replaced. Retain it for replacement in case the bracket is ever removed.

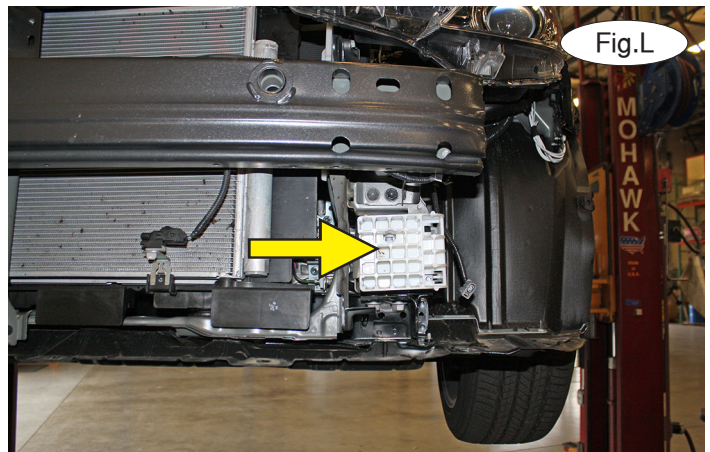



BASEPLATE KIT INSTALLATION INSTRUCTIONS

KIT# 521195-4

06/23/16
KS

ROADMASTER, Inc. 6110 NE 127th Ave. Vancouver, WA 98682 360-896-0407 fax 360-735-9300 www.roadmasterinc.com

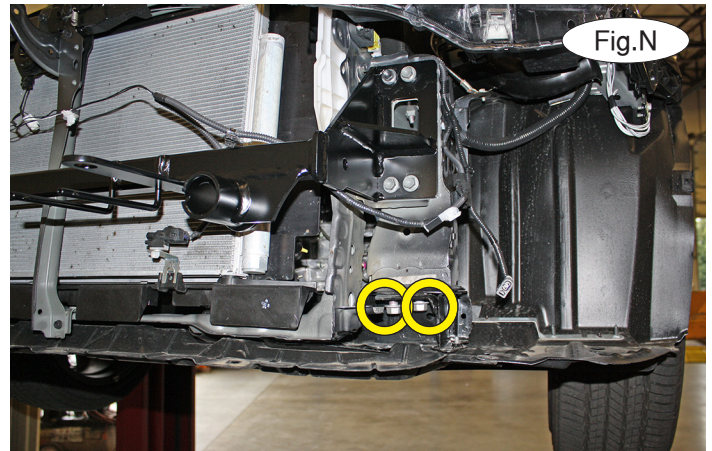
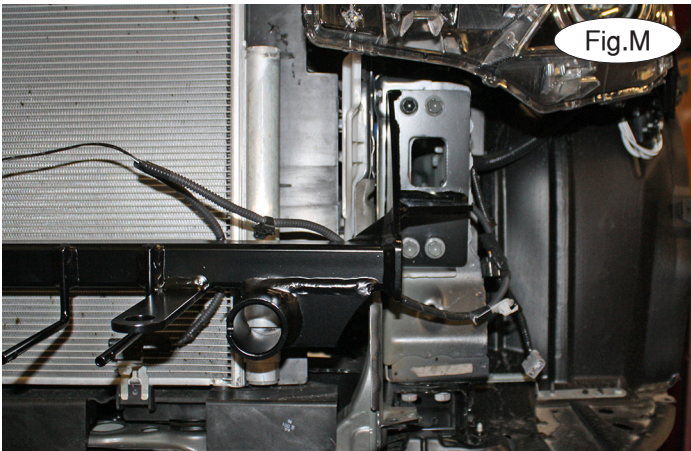

10. On each side, remove four 14mm (head) bolts attaching the bumper core to the frame. *Note:* the bumper core will not be replaced. Retain it for replacement in case the bracket is ever removed.

Place the main receiver brace over the mounts you just exposed. Then, replace the 14mm (head) bolts (Fig.M). *Note:* ensure proper alignment, as the bolts will receive Loctite® Red and will be torqued at the end of these instructions.

11. On each side, remove two 17mm (head) bolts attaching the frame to the subframe (Fig.N).

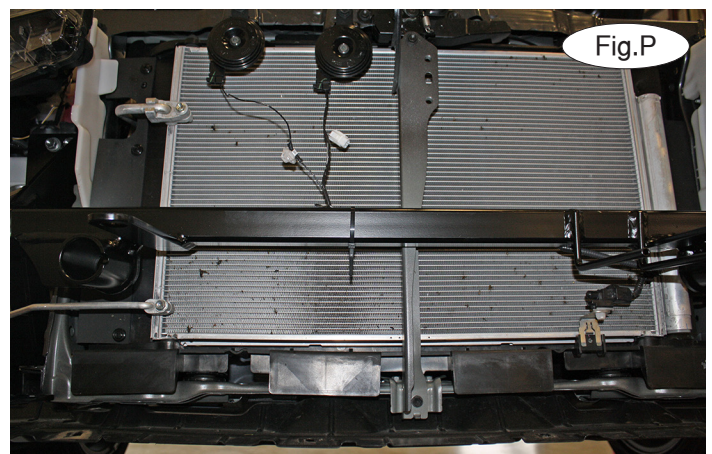
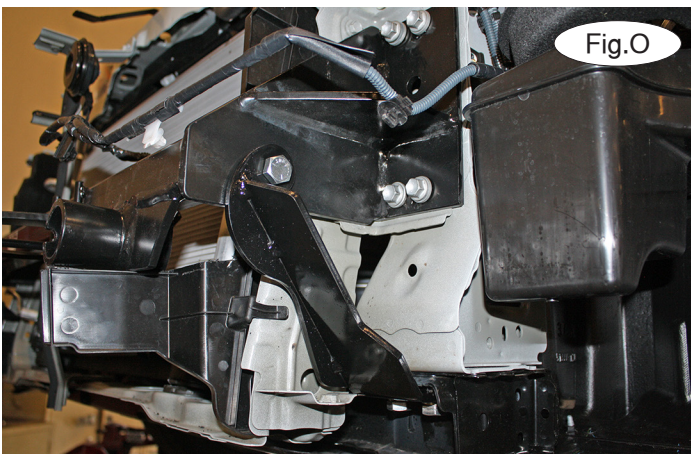

12. On each side, align the lower brace with the holes exposed in the previous step. Use the two supplied 12mm x 1.25 x 50mm bolts and 12mm lock washers and bolt up through the bottom mounts. On the upper point, bolt the main receiver brace to the lower brace using the supplied 1/2" x 1 1/4" bolt, 1/2" lock washer and finish with a 1/2" nut (Fig.O).

13. Tighten all bolts to the bolt torque requirements found at the end of these instructions. *Note:* use Loctite® Red on all nuts and bolts.

14. Zip tie the wiring loom to the main receiver brace (Fig.P).

15. On each side, trim the fascia using the yellow lines in Figure Q as an approximate reference for trimming.

16. Reinstall the fascia, reversing steps 1 through 5.

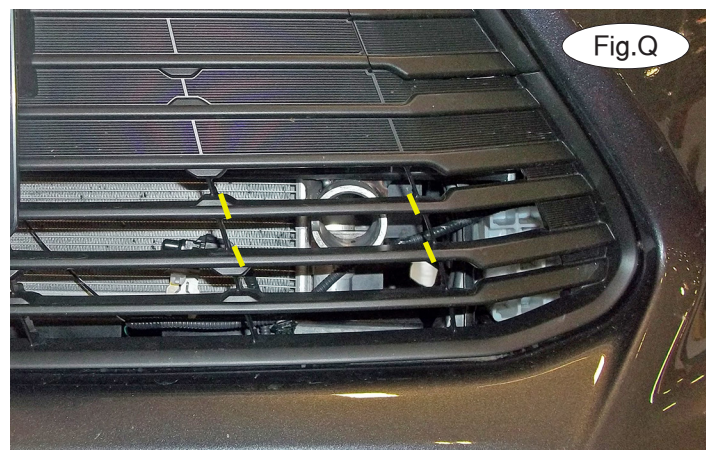



BASEPLATE KIT INSTALLATION INSTRUCTIONS

KIT# 521195-4

06/23/16
KS

ROADMASTER, Inc. 6110 NE 127th Ave. Vancouver, WA 98682 360-896-0407 fax 360-735-9300 www.roadmasterinc.com



17. **Note: the following four images are for illustration purposes only, as your specific application may be slightly different.**

The spring-loaded pin on the removable arm snaps into a notch on the receiver, locking the removable arm into its final towing position. Before inserting each arm into the receiver, verify that the spring is working by ensuring that the spring-loaded pin moves easily back and forth within the barrel when pulled and that it can be pulled flush with the face of the barrel (Fig.R and Fig.S).

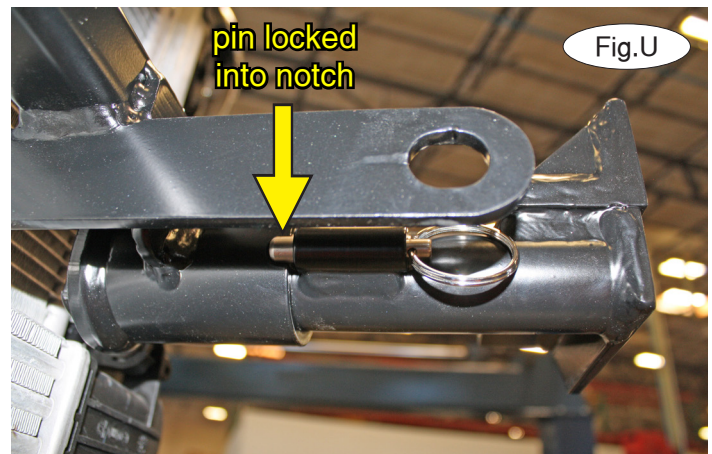
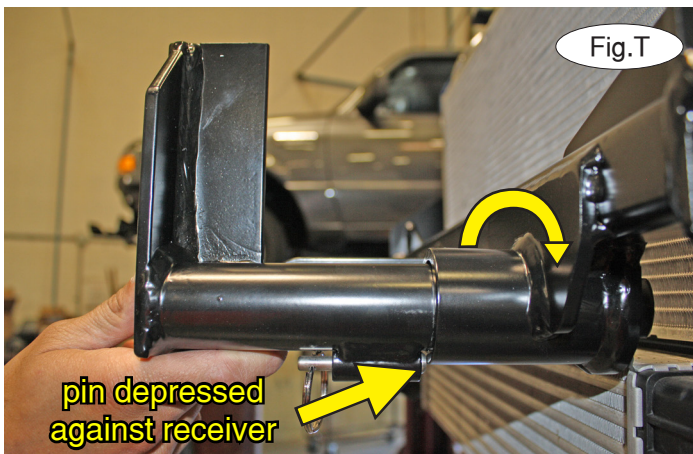

18. On each side, insert the removable front bracket arm into the front receiver 90 degrees from its final towing position, depressing the spring-loaded pin against the receiver (Fig.T). Now, twist back 90 degrees until the spring-loaded pin snaps into place in the notch on the receiver, locking the arm into place in its final towing position (Fig.U).

Please note: it is the owner's responsibility to ensure the locking of the pins before towing. Otherwise, failure of the towing system will result.

19. Install the tow bar to the mounting bracket according to the manufacturer's instructions.



BASEPLATE KIT INSTALLATION INSTRUCTIONS

KIT# 521195-4

06/23/16
KS

ROADMASTER, Inc. 6110 NE 127th Ave. Vancouver, WA 98682 360-896-0407 fax 360-735-9300 www.roadmasterinc.com

IMPORTANT!

Safety cables are required by law. When towing, connect safety cables to the safety cable tabs shown in Figure V. Make certain there is adequate slack in the cables to allow a full turning radius; otherwise, damage will result. If necessary, longer cables or cable extensions are available.

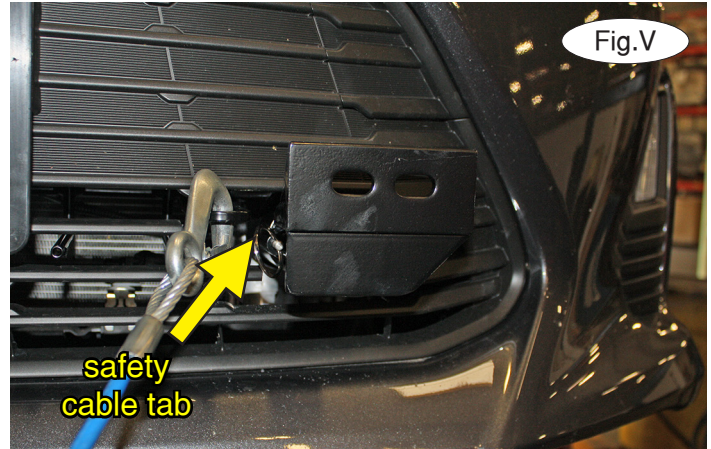

Fig.V

Three options for attaching the wiring plug to the main receiver brace

For six-wire plugs: use the two supplied 3/4" self-tapping screws to attach the electrical plug directly to the rods on the front of the main receiver brace.

For four-wire round plugs: attach to the plug mounting plate and then use the two supplied 3/4" self-tapping screws to attach the mounting plate to the rods on the front of the main receiver brace.

For four-wire flat plugs: place the plug through the mounting plug plate, and then secure it using the supplied zip tie on the front of the plug (Fig.W). Use the two supplied 3/4" self-tapping screws to attach the mounting plate to the rods on the front of the main receiver brace.

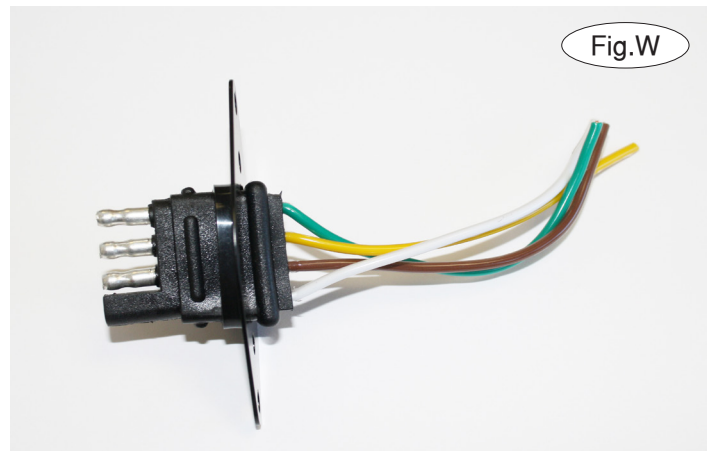

Fig.W

BOLT TORQUE REQUIREMENTS

Note: The torque values represented below are intended as general guidelines. Torque requirements for specific applications may vary. Roadmaster does not warrant this information to be accurate for all applications and disclaims all liability for any claims or damages which may result from its use.

STANDARD BOLTS

Thread Size	Grade	Torque
5/16	5	13 ft./lb.
3/8	5	23 ft./lb.
7/16	5	37 ft./lb.
1/2	5	56 ft./lb.
5/8	5	150 ft./lb.

METRIC BOLTS

Thread Size	Grade	Plated / Unplated
8mm-1.0	8.8	20 ft./lb. 18 ft./lb.
8mm-1.25	8.8	19 ft./lb. 18 ft./lb.
10mm-1.25	8.8	38 ft./lb. 36 ft./lb.
10mm-1.5	8.8	37 ft./lb. 35 ft./lb.

METRIC BOLTS

Thread Size	Grade	Plated / Unplated
12mm-1.25	8.8	70 ft./lb. 65 ft./lb.
12mm-1.5	8.8	66 ft./lb. 61 ft./lb.
12mm-1.75	8.8	65 ft./lb. 60 ft./lb.
14mm-2.0	8.8	104 ft./lb. 97 ft./lb.

All illustrations and specifications contained herein are based on the latest information available at the time of publication approval. ROADMASTER, INC. reserves the right to make changes at any time without notice in material, specification and models or to discontinue models.



BASEPLATE KIT INSTALLATION INSTRUCTIONS

KIT# 521195-4

06/23/16
KS

ROADMASTER, Inc. 6110 NE 127th Ave. Vancouver, WA 98682 360-896-0407 fax 360-735-9300 www.roadmasterinc.com

Instructions for Scion iM models

*Note: this bracket fits both Scion tC and iM models. For tC models, please see the first half of this instruction booklet.
For Scion tC instructions, follow the steps below.*

This is one of our EZ4 series brackets, which allows the visible front portion of the bracket to be easily removed from the front of the vehicle (Fig.A and Fig.B). The bracket consists of a main receiver brace, two lower braces, two removable front braces, and a hardware pack.

The main receiver brace mounts to the frame and the bumper core mounts. The removable front braces install in the main receiver brace.

Before starting the installation, lay out the kit components in order, as they will be used. This will give you a visual idea of how the components work, and will also confirm that everything is present and accounted for.

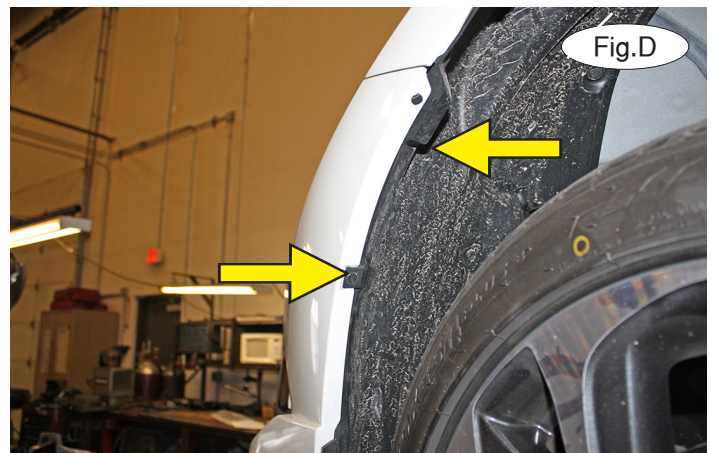
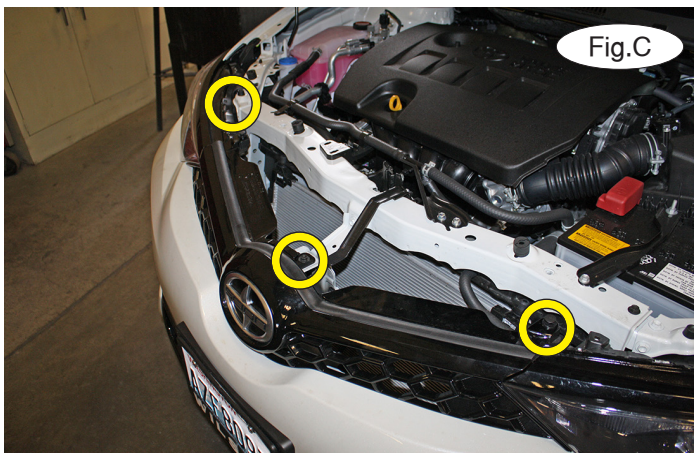

1. **Important:** please use all supplied bolts and parts and read all instructions carefully before beginning this installation. The majority of questions you may have can be answered within the text, and proper installation will ensure safe and secure travel. Now, begin the installation.

2. Remove two plastic fasteners and one 10mm (head) bolts attaching the top of the fascia to the core support and headlights (Fig.C).

3. On each side, remove one plastic fastener and one center pin fastener attaching the fender liner to the fascia (Fig.D – driver's side). Use a flat head screwdriver to rotate the center pin fastener 90 degrees and slide the fender liner clip off the fascia flange.



BASEPLATE KIT INSTALLATION INSTRUCTIONS

KIT# 521195-4

06/23/16
KS

ROADMASTER, Inc. 6110 NE 127th Ave. Vancouver, WA 98682 360-896-0407 fax 360-735-9300 www.roadmasterinc.com

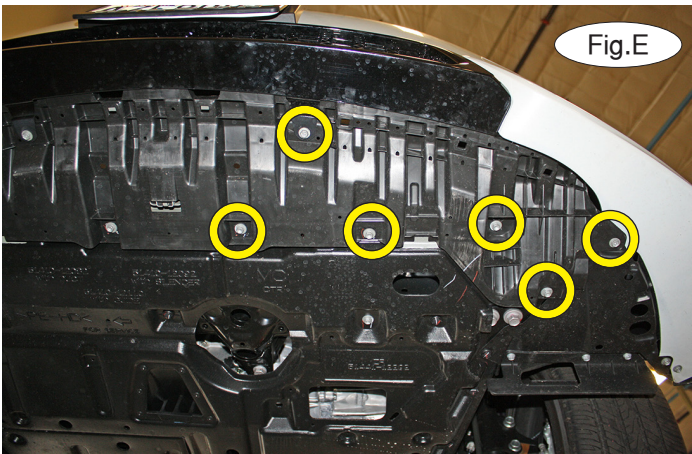

4. On each side, remove six 10mm screws attaching the fender liner and splash shield to the subframe (Fig.E – driver's side).

5. On each side, release the fender liner fastener from the fascia and pull the corner of the fascia off the alignment posts. Continue pulling out on the corner to release the locking strip (Fig.F). Disconnect the fog lights, if the vehicle is so equipped.

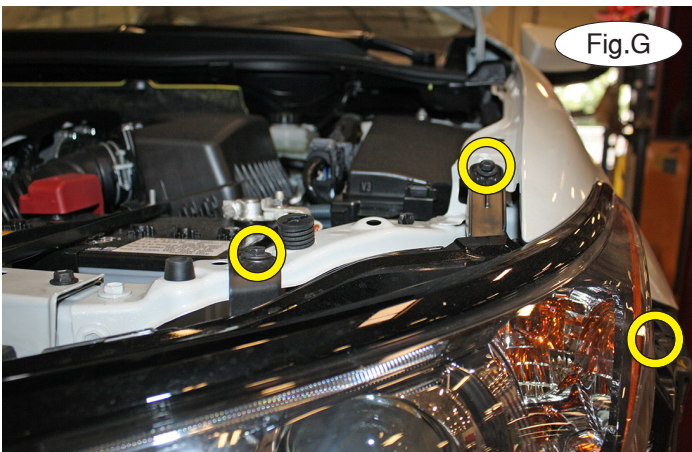

6. On each side, remove three 10mm (head) bolts attaching the headlight to the frame (Fig.G).

7. On each side, pry up on the tab over the recessed nut to release it (Fig.H). Then, pull out firmly on each headlight to release it from the locating clip (Fig.I). Set the headlights aside for now.





BASEPLATE KIT INSTALLATION INSTRUCTIONS

KIT# 521195-4

06/23/16
KS

ROADMASTER, Inc. 6110 NE 127th Ave. Vancouver, WA 98682 360-896-0407 fax 360-735-9300 www.roadmasterinc.com

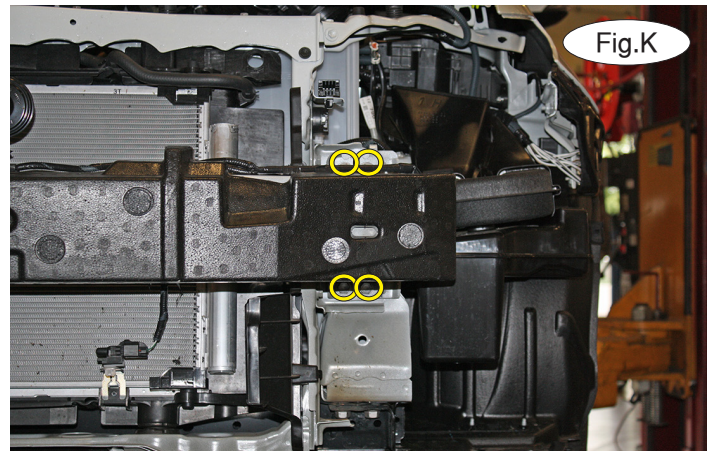
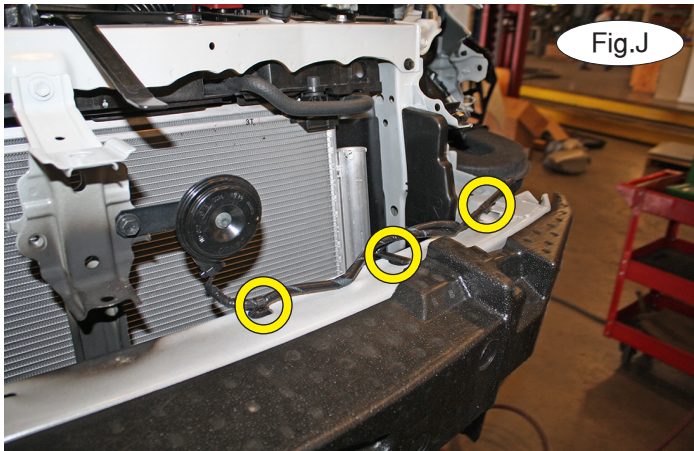

8. Release three plastic fasteners attaching the wiring harness to the bumper core (Fig.J).

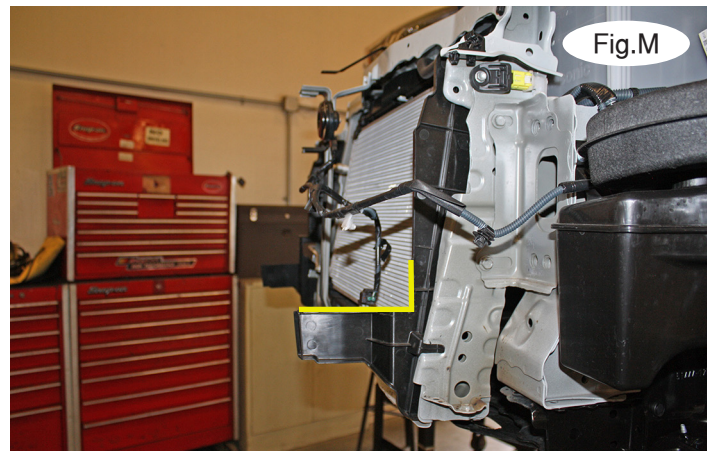
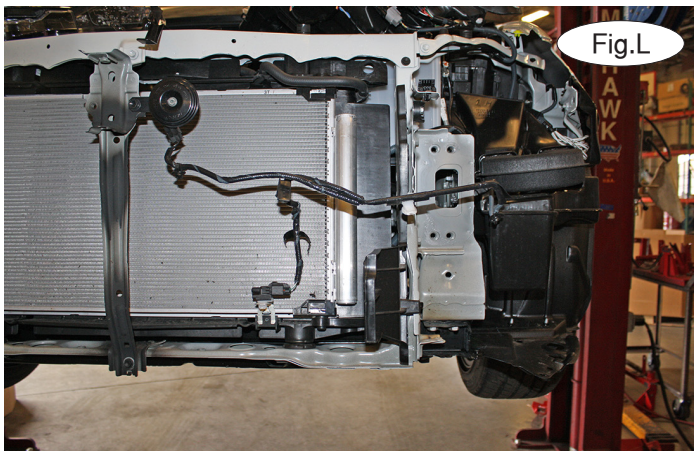

9. On each side, remove four 14mm (head) bolts attaching the bumper core to the frame rail (Fig.K and Fig.L). *Note:* the bumper core will not be replaced. Retain the bumper core for replacement in case the main receiver brace is ever removed from the vehicle.

10. On each side, trim the air dam as shown in Figure M.

11. Place the main receiver brace over the bumper core and replace the 14mm (head) bolts you removed in the previous step (Fig.N). *Note:* ensure proper alignment, as the bolts will receive Loctite® Red and will be torqued at the end of these instructions.

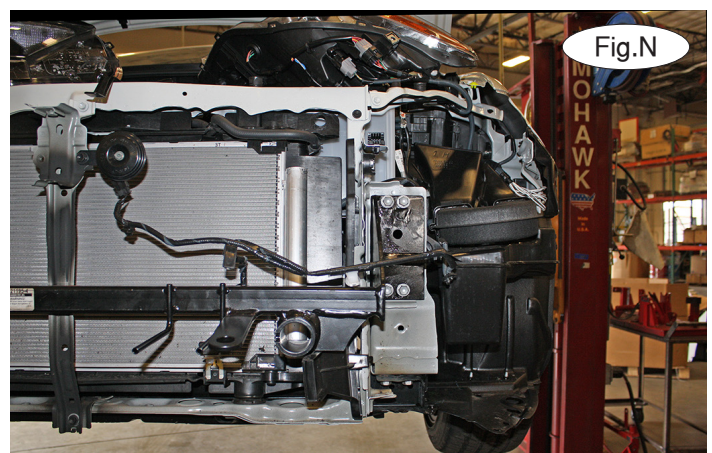



BASEPLATE KIT INSTALLATION INSTRUCTIONS

KIT# 521195-4

06/23/16
KS

ROADMASTER, Inc. 6110 NE 127th Ave. Vancouver, WA 98682 360-896-0407 fax 360-735-9300 www.roadmasterinc.com

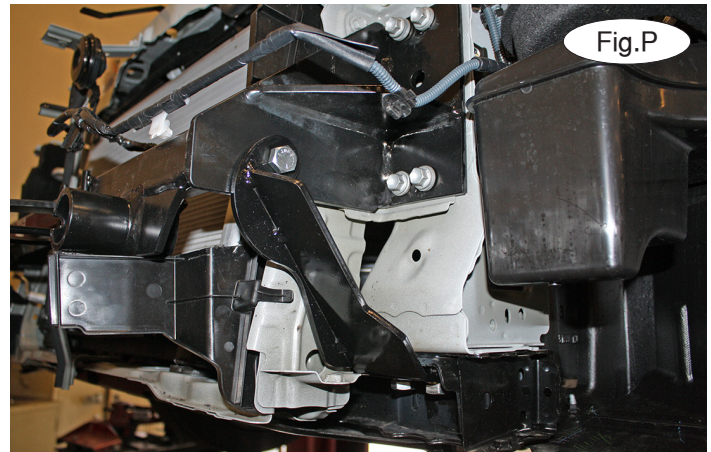
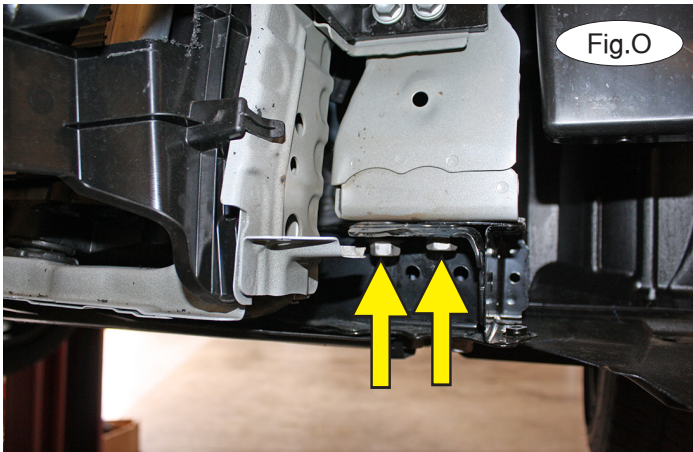

12. On the driver's side only, remove two 17mm (head) bolts attaching the subframe to the frame (Fig.O).

13. Place the driver's side lower brace over the holes you exposed in the previous step. Use the two supplied 12mm x 1.25 x 50mm bolts and 12mm lock washers and bolt up through the bottom mounts. On the upper point, bolt the main receiver brace to the lower brace using the supplied 1/2" x 1 1/4" bolt, 1/2" lock washer and finish with a 1/2" nut (Fig.P).

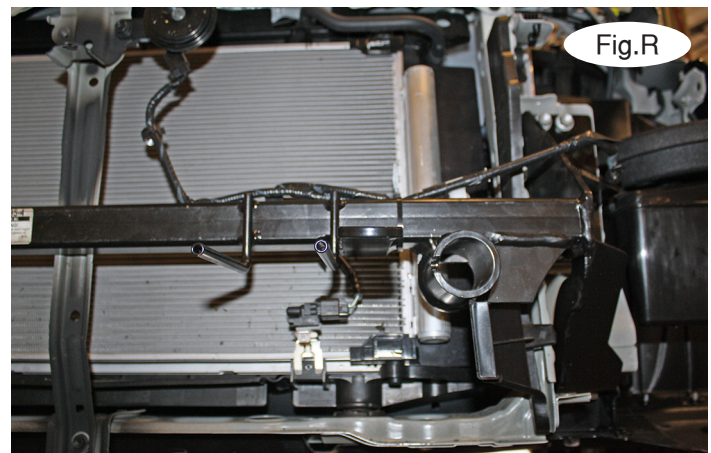

14. Repeat step 13 for the passenger side of the vehicle (Fig.Q).

15. Tighten all bolts to the bolt torque requirements found at the end of these instructions. *Note:* use Loctite® Red on all nuts and bolts.

16. Zip tie the wiring loom to the main receiver brace (Fig.R).

17. On each side, trim the fascia using the yellow lines in Figure S as an approximate reference for trimming.

18. Reinstall the fascia, reversing steps 1 through 5.

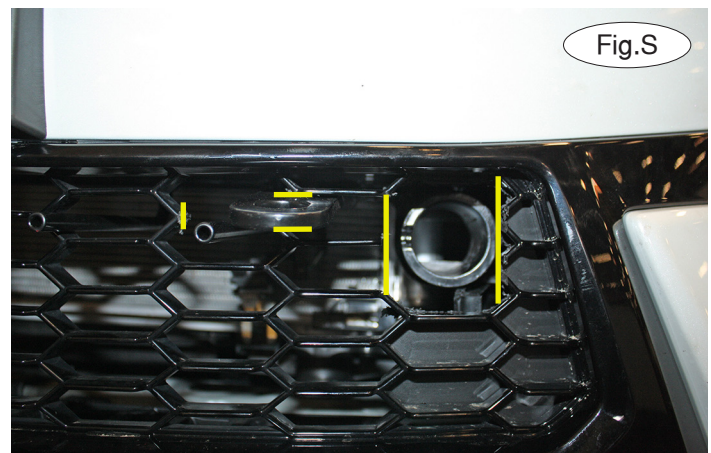

Now, return to page 6 of these instructions to finish installing the bracket arms.