



# BASEPLATE KIT INSTALLATION INSTRUCTIONS

**KIT# 521199-4**

08/07/23  
RS

ROADMASTER, Inc. 6110 NE 127th Ave. Vancouver, WA 98682 360-896-0407 fax 360-735-9300 www.roadmasterinc.com

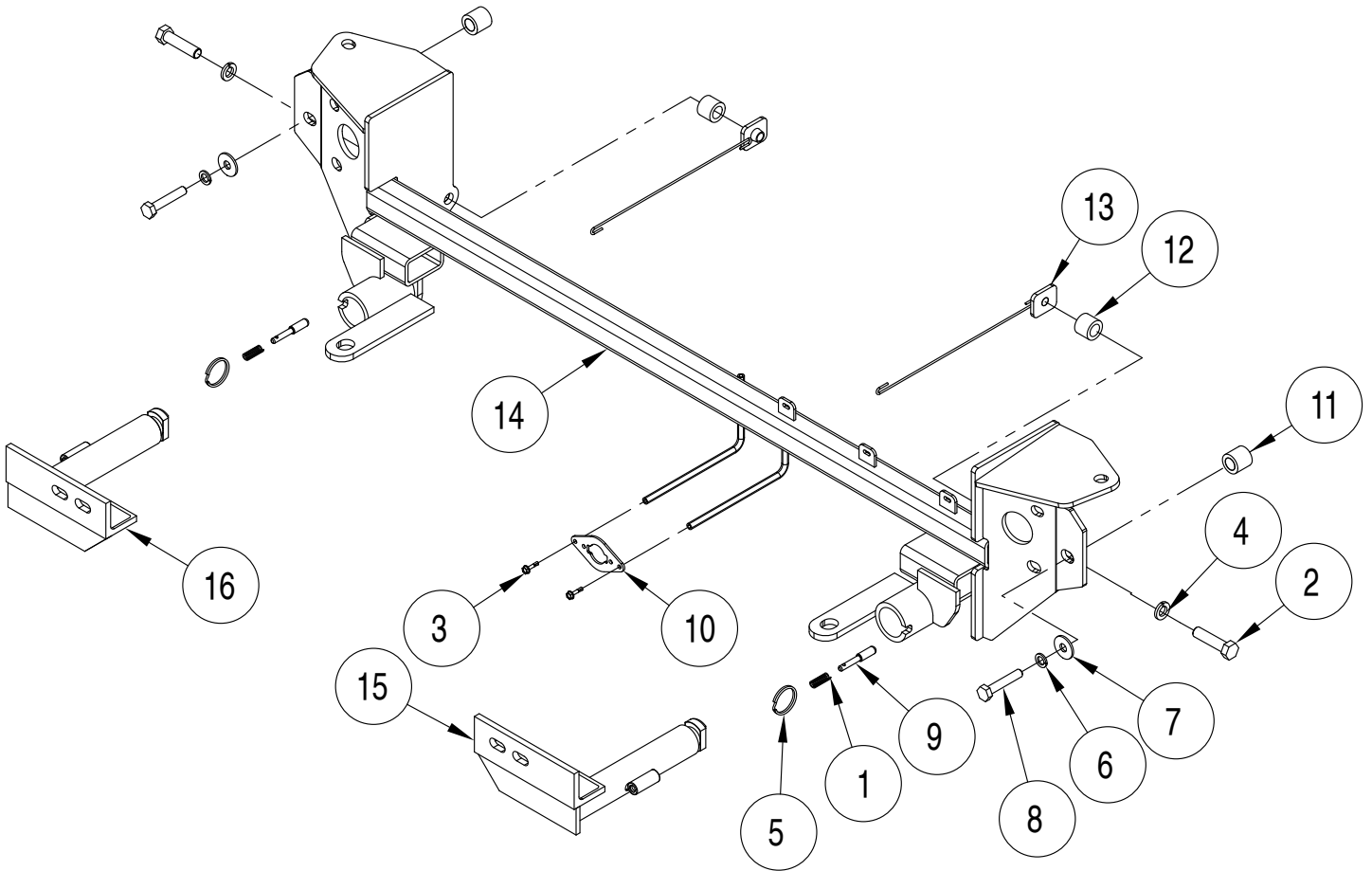

ITEM	QTY	DESCRIPTION	PART NUMBER
1	2	SPRING	200146-00
2	2	1/2" x 2" BOLT	350097-00
3	2	#10 x 3/4" SELF DRILLING SCREW	350247-35
4	2	1/2" LOCK WASHER	350309-00
5	2	RING	350520-00
6	2	M10 LOCK WASHER	355715-00
7	2	M10 FENDER WASHER	355716-00
8	2	M10 x 1.25 x 55 mm BOLT	356206-00
9	2	LOCK PIN	A000008
10	1	WIRE PLUG PLATE	A003801
11	2	1" O.D. x 0.188" WALL x 15/16" SPACER	A003104
12	2	1" O.D. x 0.188" WALL X 13/16" SPACER	A006239
13	2	1 1/4" x 1 1/2" THREADED BACKING PLATE W/ 10" ROD	C002501
14	1	MAIN RECEIVER	C003736
15	1	DRIVER SIDE ARM	C003737
16	1	PASSENGER SIDE ARM	C003738



# BASEPLATE KIT INSTALLATION INSTRUCTIONS

**KIT# 521199-4**

08/07/23  
RS

ROADMASTER, Inc. 6110 NE 127th Ave. Vancouver, WA 98682 360-896-0407 fax 360-735-9300 www.roadmasterinc.com

This is one of our crossbar style series baseplates, which allows the visible front portion to be easily removed (Fig.A and Fig.B). The kit consists of the main receiver brace, two rear support braces, removable front braces and a hardware pack.

The main receiver brace mounts to the rear support brace and frame on each side. The removable front braces insert into the receivers on each side.

Before starting the installation, lay out the kit components in order, as they will be used. This will give you a visual idea of how the components work, and will also confirm that everything is present and accounted for.



**IMPORTANT:** All baseplates **must** be assembled with all the bolts left loose for final adjustment and positioning (before tightening) unless otherwise instructed. All bolts **must** be torqued for proper strength. If more than one bolt is used per fastening point, the diagram may only show one. Use flat washers over all slotted holes and lock washers on all fasteners.

## WARNING

Failure to heed these warnings or follow the installation instructions may result in a voided warranty, loss of towed vehicle, personal injury or death.

- Do not weld or modify this baseplate or its components. Welding or modification will void the warranty.
- Do not use this document as a basis to design/fabricate a baseplate, as it may not show all parts or structural components.
- We strongly recommend professional installation.
- If the towed vehicle has been in an accident, it must be properly repaired before attaching the baseplate. Do not install the baseplate if any structural frame damage is found.
- The installer must use all bolts and parts supplied. If running changes were made by the vehicle manufacturer after this kit was designed, some bolts or other fasteners may no longer be the correct size. It is the installer's responsibility to verify this kit is securely fastened to the vehicle.
- Use Loctite® Red on all bolts used to secure this baseplate. Torque all bolts to the specifications found at the end of these instructions. Do not over-torque the bolts or failure may occur.
- The installer must inspect the baseplate to ensure adequate clearance, particularly around hoses, air conditioner lines, radiators, etc. or non-warranty failure may result.
- Roadmaster manufactures many styles of baseplates. If your baseplate has removable arms, they must be removed before driving the vehicle, unless the arms can be pinned or padlocked in place. If not secured, the arms could vibrate out.
- Some motorhome chassis have such a tight turning radius that you can damage your motorhome, towed vehicle, tow bar or baseplate while turning sharply. Before getting on the road, test your turning radius in an empty parking lot. Turning too sharply could result in non-warranty damage to your towing system, motorhome and/or towed vehicle.
- Do not back up with the towed vehicle attached or non-warranty damage will occur to your towing system or vehicles.
- The safety cables must connect the towing vehicle to the towed vehicle frame to frame, with the cables crossed, with enough slack for sharp turns. See cable instructions for proper routing. Failure to do so will result in non-warranty damage and/or the loss of the towed vehicle.
- This kit is designed for use with ROADMASTER tow bars and ROADMASTER adapters only. Using this kit with other brands, without an approved ROADMASTER adapter, may result in non-warranty damage or injury.
- Receiver extensions and out-of-level towing situations of 3 inches or more. This can cause the system to swing much higher and lower, causing excessive strain on the tow bar, baseplate and frame. That can cause the towing system to fail, causing property damage, personal injury or even death. If you must use a receiver extension or drop hitch to tow, it will reduce your receiver's weight capacity by 1/3 to avoid damaging your system. Never use more than one extension and/or drop hitch, as this will void your warranty.
- Every 3,000 miles, the owner must inspect all mounting points for cracks or fatigue, and check the fasteners for proper torque, according to the bolt torque requirements chart on the last page of these instructions.
- The owner must follow the vehicle manufacturer's instructions to prepare the vehicle for towing. Failure to do so may cause severe damage to the vehicle.
- This baseplate is only warranted for the original installation. Installing a used baseplate on another vehicle is not recommended and will void the warranty.



# BASEPLATE KIT INSTALLATION INSTRUCTIONS

**KIT# 521199-4**

08/07/23  
RS

ROADMASTER, Inc. 6110 NE 127th Ave. Vancouver, WA 98682 360-896-0407 fax 360-735-9300 www.roadmasterinc.com

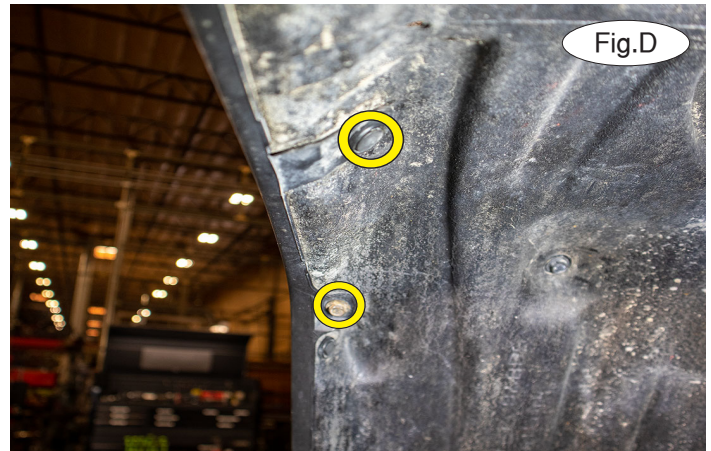
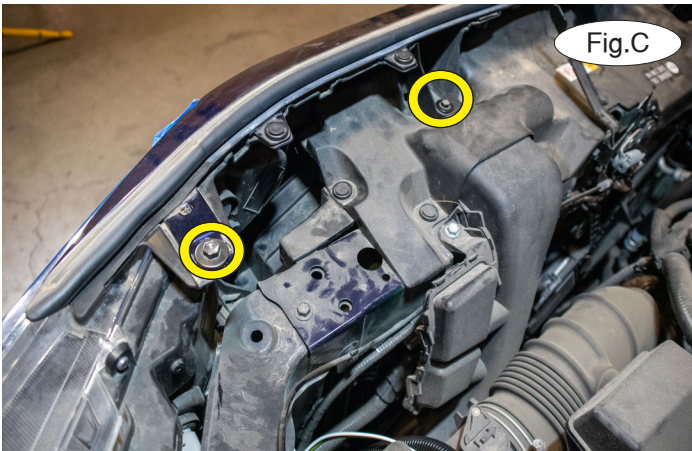

1. **Important:** Please use all supplied bolts and parts and read all instructions carefully before beginning this installation. The majority of questions you may have can be answered within the text, and proper installation will ensure safe and secure travel. Now, begin the installation. On each side, remove two 10mm shoulder bolts attaching the top of the fascia to the radiator support (Fig.C).

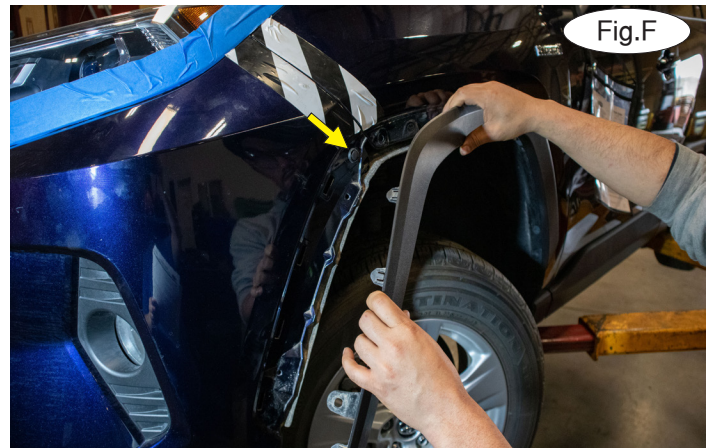
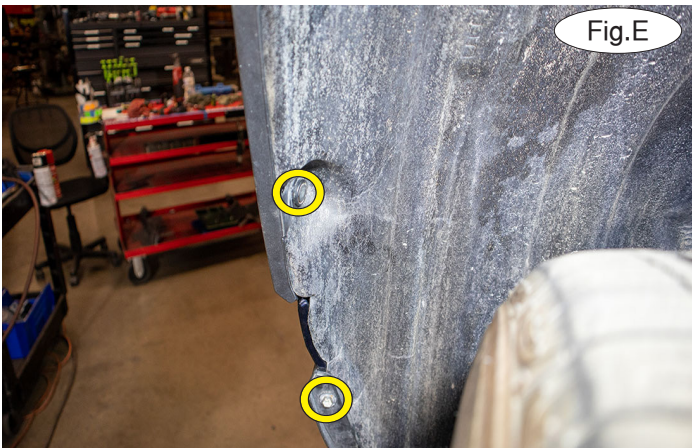

2. On each side, remove one Phillips screw, one 10mm screw and three plastic fasteners attaching the fender trim to the fascia (Fig.D and Fig.E).

3. On each side, starting at the bottom of the trim, pull outward, releasing the plastic clips until about halfway up the wheel well. Use a soft rag to hold it away from the vehicle. Then, remove one plastic fastener attaching the lower corner of the fascia to the fascia (Fig.F).

4. On each side, remove three 10mm screws attaching the splash guard to the fender liner (Fig.G). Then, pull down gently to release one plastic arrowhead clip (Fig.H – next page). Set the splash guard aside for now.





# BASEPLATE KIT INSTALLATION INSTRUCTIONS

**KIT# 521199-4**

08/07/23  
RS

ROADMASTER, Inc. 6110 NE 127th Ave. Vancouver, WA 98682 360-896-0407 fax 360-735-9300 www.roadmasterinc.com

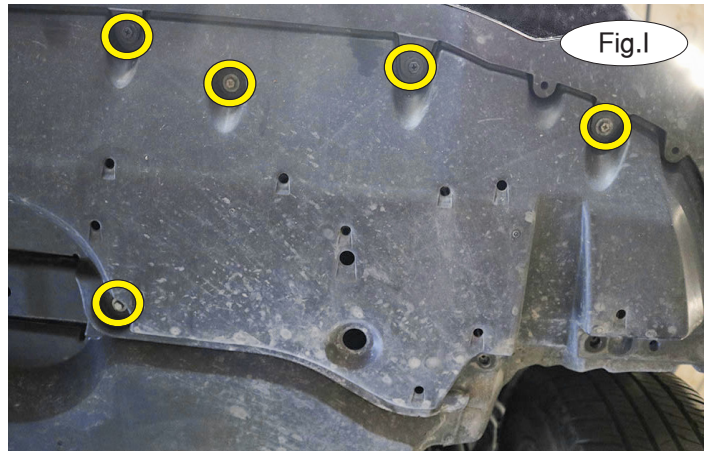

5. On each side, remove four 10mm screws and one 10mm bolt attaching the forward splash shield to the fascia and subframe (Fig.J). Set the splash shield aside for now.

6. On the driver's side only, unplug one gray and one black wiring harness from the back of the fascia (Fig.J).

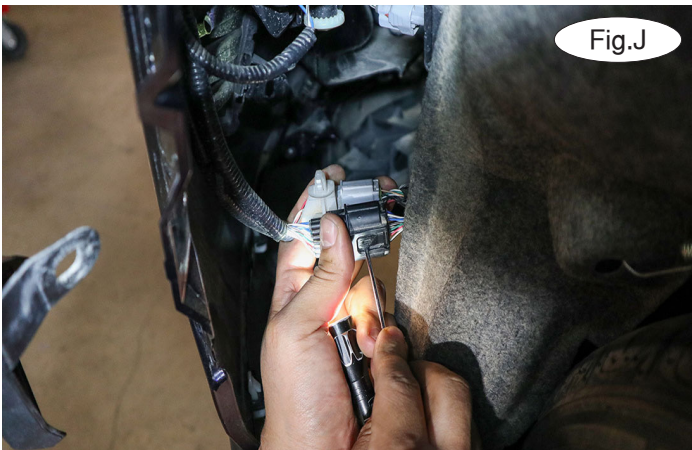

7. On each side, pull out on the fascia to release the clips along the fender seam and under the headlight (Fig.K). Set it aside for now.

8. Pull straight out to remove the foam shock absorption pad from the bumper core (Fig.L). It will not be replaced.

9. Release three clips attaching the wiring harness to the top of the bumper core (Fig.M).

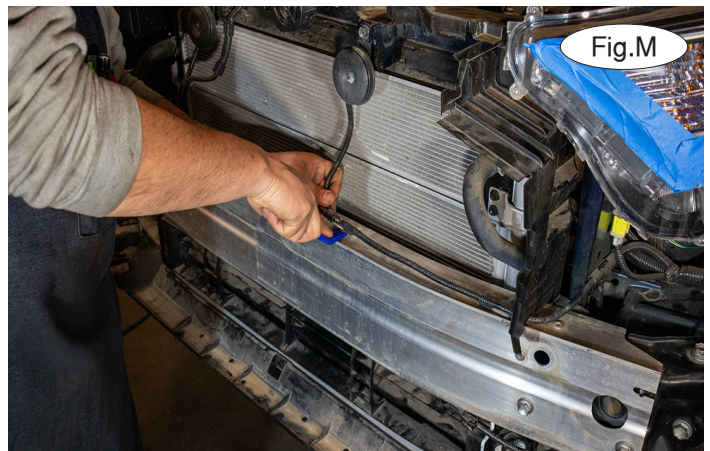



# BASEPLATE KIT INSTALLATION INSTRUCTIONS

**KIT# 521199-4**

08/07/23  
RS

ROADMASTER, Inc. 6110 NE 127th Ave. Vancouver, WA 98682 360-896-0407 fax 360-735-9300 www.roadmasterinc.com

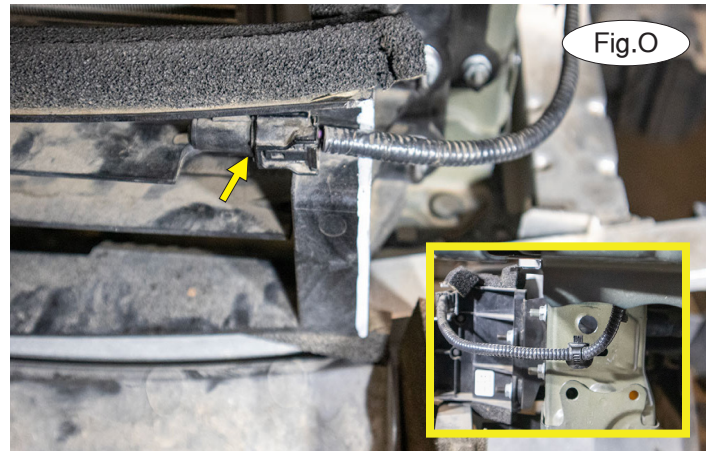
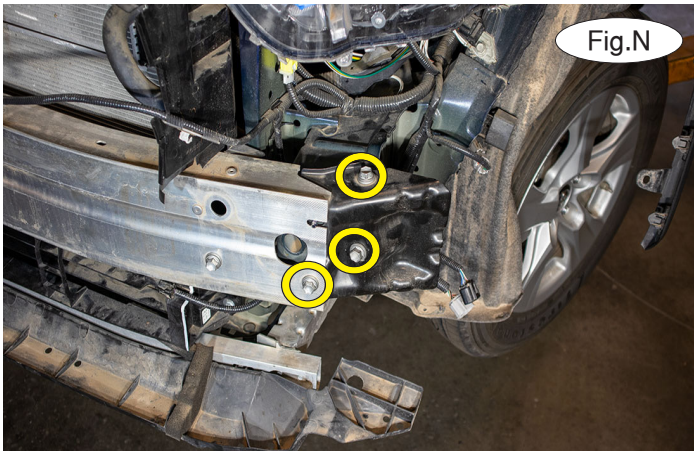

10. Then, on each side, remove three 14mm bolts attaching the bumper core to the ends of the frame (Fig.N). The bumper core will not be reinstalled but retain the hardware. Only two of the bolts will be replaced later on in these instructions.

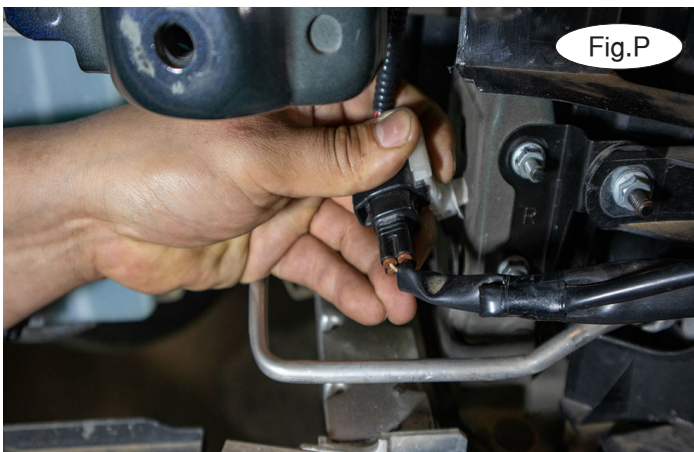

11. On the driver's side, unplug the ambient temperature sensor (Fig.O) and detach the plastic fastener from the other end from the radiator housing (Fig.O – inset). On the passenger side, unplug the active air shutter system (Fig.P), if the vehicle is so equipped, and release it from the radiator housing.

12. On the driver's side only, trim approximately  $\frac{1}{4}$ " of material off the driver's side end of the active air shutter housing (Fig.Q – yellow lines).

13. On each side, measure  $1\frac{1}{2}$ " of material off the driver's side end of the active air shutter housing (Fig.R).

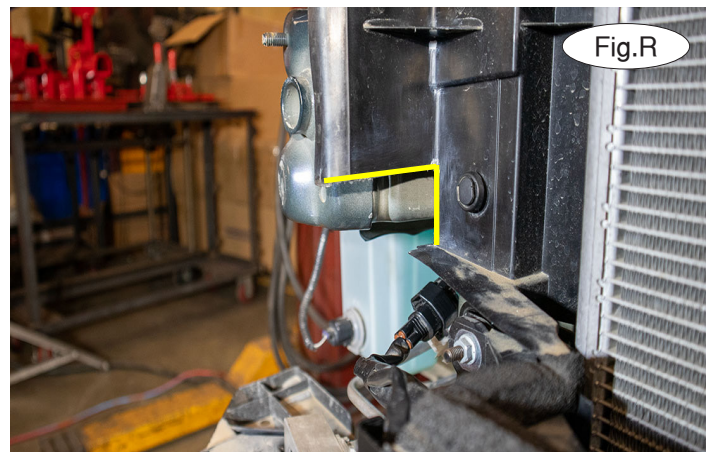



# BASEPLATE KIT INSTALLATION INSTRUCTIONS

**KIT# 521199-4**

08/07/23  
RS

ROADMASTER, Inc. 6110 NE 127th Ave. Vancouver, WA 98682 360-896-0407 fax 360-735-9300 www.roadmasterinc.com

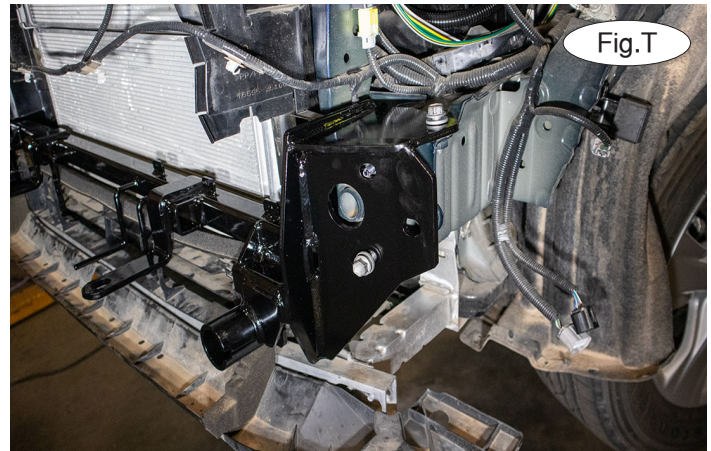
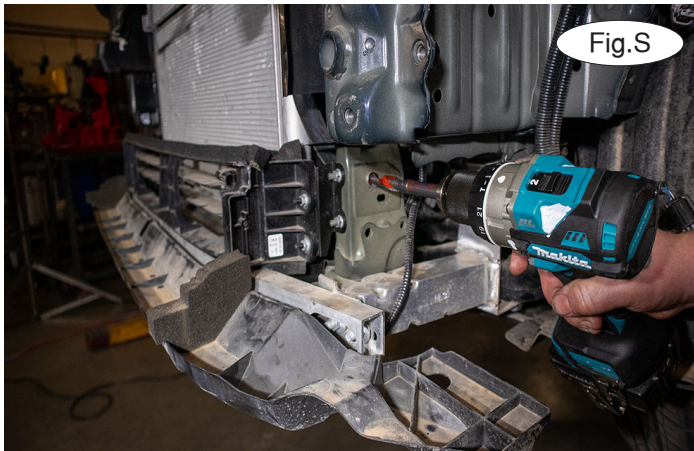

14. On each side, using a 17/32" drill bit, enlarge the existing hole in the frame (Fig.S). *Note: Use caution to avoid drilling into critical engine components.*

15. Place Loctite on one of the two 14mm factory bolts you removed in step 10. With the help of a second person, position the baseplate over the bumper core mounts and place one 14mm bolt in each upper mount (Fig.T).



16. On each side, prepare an M10 x 1.25 x 55mm bolt with Loctite. Place a 1" O.D. x .188 wall x 15/16" pipe spacer between the frame rail and baseplate. Bolt through it using your prepared bolt (Fig.U). Finish with a M10 lock washer, and a M10 flat washer.

17. Locate the two 3/16" x 1 1/4" x 1 1/2" threaded backing plates with rod and bend the rods as shown (Fig.V). Prepare two 1/2" x 2 1/2" bolts with Loctite and 1/2" lock washers. On each side, place a 1" O.D. x .188 wall x 13/16" pipe spacer between the side of the baseplate and over the hole you drilled in step 14. Then, bolt through the baseplate, pipe spacer and frame (Fig.W). Finish with the threaded backing plate with rod (Fig.W – inset).



18. Tighten the bolts in this order: 1/2" bolts, lower M14, M10, and upper M14 bolts.



# BASEPLATE KIT INSTALLATION INSTRUCTIONS

**KIT# 521199-4**

08/07/23  
RS

ROADMASTER, Inc. 6110 NE 127th Ave. Vancouver, WA 98682 360-896-0407 fax 360-735-9300 www.roadmasterinc.com



19. Reconnect the two sensors unplugged in step 11.
20. On the back of the fascia, trim off the shutter mount as shown (Fig.X).
21. Use a 2¼" hole saw to trim an opening for the receiver (Fig.Y).
22. Zip tie the wiring harness to the top of the baseplate (Fig.Z).

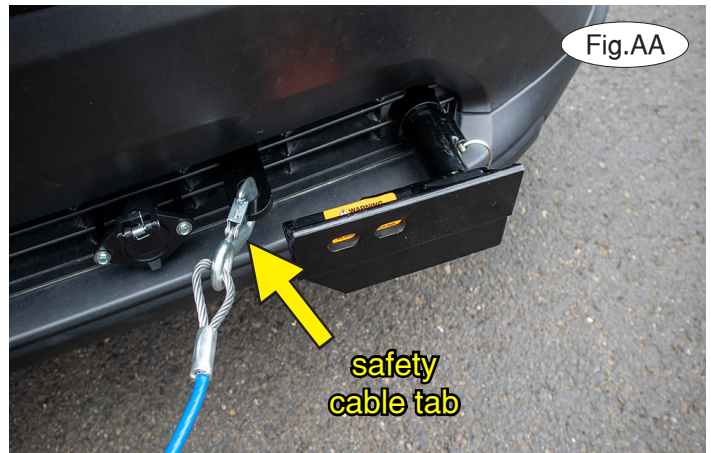
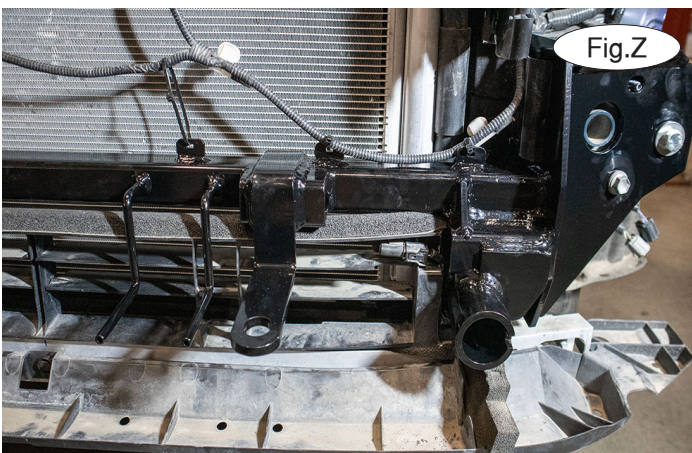

23. Reinstall the fascia, reversing steps 1 through 7.
24. On each side, insert the removable front arm into the front receiver 90 degrees from its final towing position, depressing the spring-loaded pin against the receiver. Twist back 90 degrees until the spring-loaded pin snaps into place in the notch on the receiver, locking the arm into place in its final towing position. **Please note: It is the owner's responsibility to ensure the locking of the pins before towing. Otherwise, failure of the towing system will result.**
25. Install the tow bar to the mounting bracket according to the manufacturer's instructions.

## **IMPORTANT!**

**Safety cables are required by law. When towing, connect safety cables to the safety cable tabs illustrated on the separate insert with the drawing and parts list and in Figure AA. Make certain there is adequate slack in the cables to allow a full turning radius; otherwise, damage will result. If necessary, longer cables or cable extensions are available.**



# BASEPLATE KIT INSTALLATION INSTRUCTIONS

**KIT# 521199-4**

08/07/23  
RS

ROADMASTER, Inc. 6110 NE 127th Ave. Vancouver, WA 98682 360-896-0407 fax 360-735-9300 www.roadmasterinc.com

## Three options for attaching the wiring plug to the main receiver brace

**For six-wire plugs:** Use the two supplied 3/4" self-tapping screws to attach the electrical plug directly to the rods on the front of the main receiver brace.

**For four-wire round plugs:** Attach to the plug mounting plate and then use the two supplied 3/4" self-tapping screws to attach the mounting plate to the rods on the front of the main receiver brace.

**For four-wire flat plugs:** Place the plug through the mounting plug plate, and then secure it using the supplied zip tie on the front of the plug (Fig.BB). Use the two supplied 3/4" self-tapping screws to attach the mounting plate to the rods on the front of the main receiver brace.

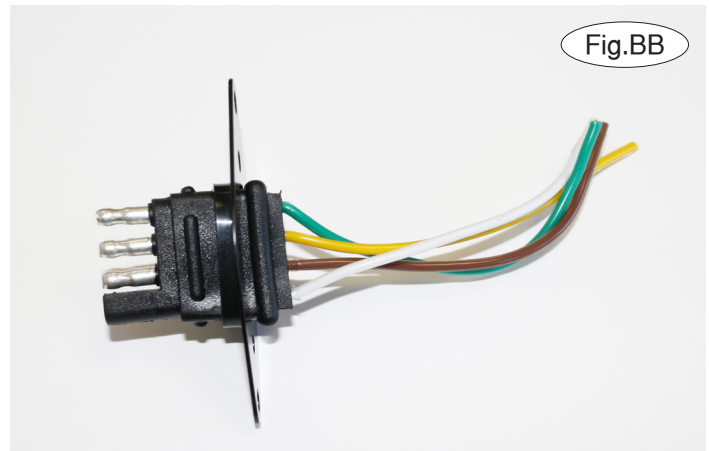

## BOLT TORQUE REQUIREMENTS

Note: The torque values represented below are intended as general guidelines. Torque requirements for specific applications may vary. Roadmaster does not warrant this information to be accurate for all applications and disclaims all liability for any claims or damages which may result from its use.

### STANDARD BOLTS

Thread Size	Grade	Torque
5/16-18	5	13 ft./lb.
3/8-16	5	23 ft./lb.
7/16-14	5	37 ft./lb.
1/2-13	5	57 ft./lb.
5/8-11	5	112 ft./lb.

### METRIC BOLTS

Thread Size	Grade	Torque
6mm-1.0	8.8	6 ft./lb.
8mm-1.0	8.8	18 ft./lb.
8mm-1.25	8.8	16 ft./lb.
10mm-1.25	8.8	36 ft./lb.
10mm-1.5	8.8	31 ft./lb.

### METRIC BOLTS

Thread Size	Grade	Torque
12mm-1.25	8.8	64 ft./lb.
12mm-1.5	8.8	60 ft./lb.
12mm-1.75	8.8	55 ft./lb.
14mm-2.0	8.8	88 ft./lb.

All illustrations and specifications contained herein are based on the latest information available at the time of publication approval. ROADMASTER, INC. reserves the right to make changes at any time without notice in material, specification and models or to discontinue models.