



BASEPLATE KIT INSTALLATION INSTRUCTIONS

KIT# 521238-5

01/29/24
KS

ROADMASTER, Inc. 6110 NE 127th Ave. Vancouver, WA 98682 360-896-0407 fax 360-735-9300 www.roadmasterinc.com

Important

Note: This baseplate will not accommodate the Guardian rock shield, some models of the Tow Defender, Stowaway or the Stow-Master and StowMaster All Terrain tow bars.

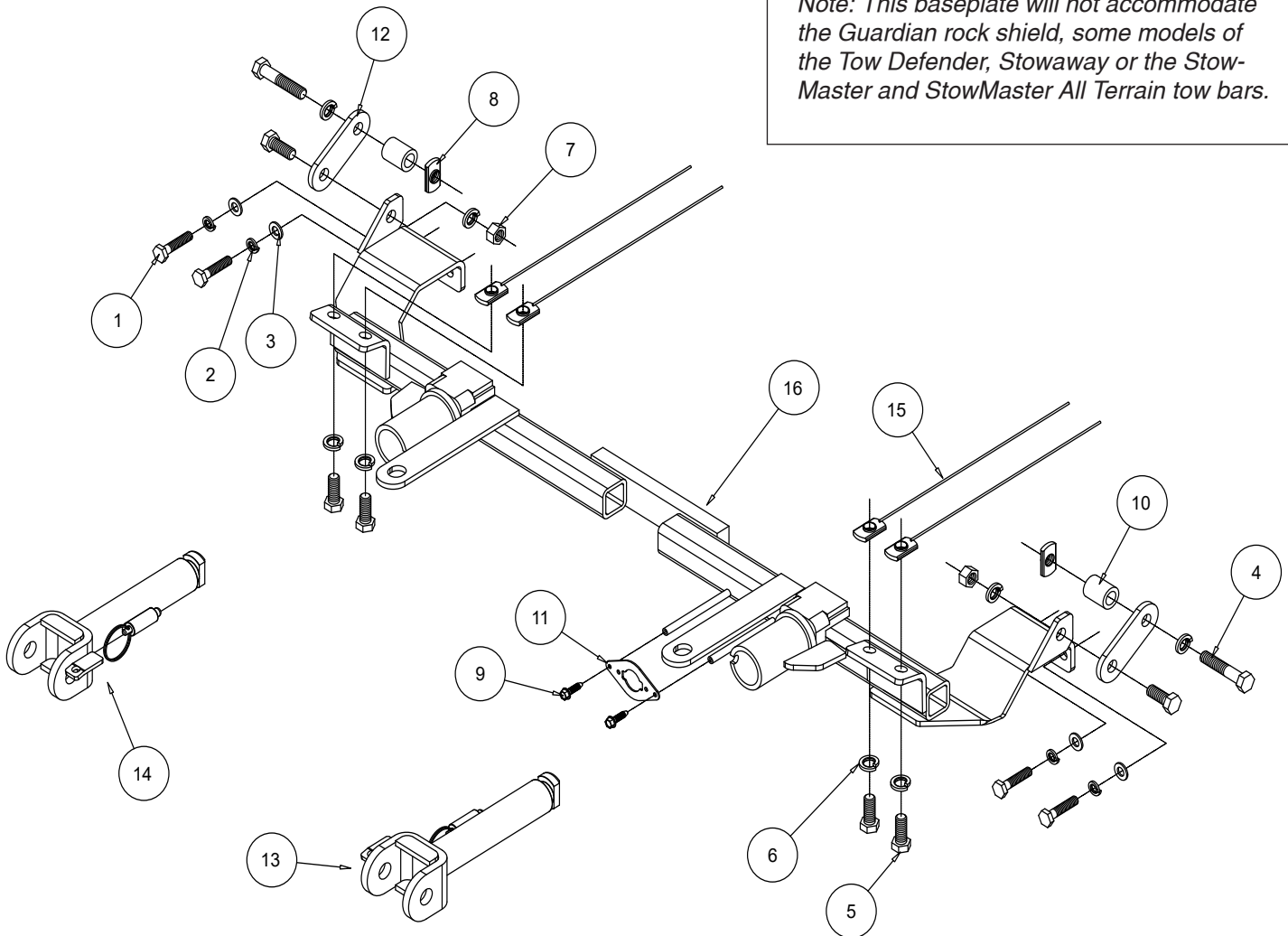

ITEM	QTY	NAME	PART #
1.....	4.....	10mm x 1.5 x 45mm BOLTS	356104-00
2.....	4.....	10mm LOCK WASHER.....	355715-00
3.....	4.....	3/8" FLAT WASHER.....	350304-00
4.....	2.....	1/2" x 2 1/2" BOLT	350099-00
5.....	6.....	1/2" x 1 1/4" BOLT	350094-00
6.....	8.....	1/2" LOCK WASHER	350309-00
7.....	2.....	1/2" NUT.....	350258-00
8.....	2.....	1/2" TAB WELD NUT	350270-00
9.....	2.....	#10 x 3/4" SELF DRILLING SCREW	350247-35
10.....	2.....	1" O.D. x 0.188 WALL x 1 1/4" TUBE SPACER.....	A001055
11.....	1.....	WIRE PLUG PLATE.....	A003801
12.....	2.....	REAR MOUNTING BRACE	A005334
13.....	1.....	DRIVER SIDE ARM	C002383
14.....	1.....	PASSENGER SIDE ARM.....	C002384
15.....	4.....	1/2" WELD NUT WITH 12" ROD.....	C002852
16.....	1.....	MAIN WELDMENT.....	C002856



BASEPLATE KIT INSTALLATION INSTRUCTIONS

KIT# 521238-5

01/29/24
KS

ROADMASTER, Inc. 6110 NE 127th Ave. Vancouver, WA 98682 360-896-0407 fax 360-735-9300 www.roadmasterinc.com

This is one of our EZ5Twistlock series brackets, which allows the visible front portion of the bracket to be easily removed from the front of the vehicle (Fig.A and Fig.B). The bracket consists of a main receiver brace, two removable front braces, and a hardware pack.

The main receiver brace mounts to the frame and the bumper core. The removable front braces install in the main receiver brace.

Before starting the installation, lay out the kit components in order, as they will be used. This will give you a visual idea of how the components work, and will also confirm that everything is present and accounted for.



IMPORTANT: All baseplates **must** be assembled with all the bolts left loose for final adjustment and positioning (before tightening) unless otherwise instructed. All bolts **must** be torqued for proper strength. If more than one bolt is used per fastening point, the diagram may only show one. Use flat washers over all slotted holes and lock washers on all fasteners.

WARNING

Failure to heed these warnings or follow the installation instructions may result in a voided warranty, loss of towed vehicle, personal injury or death.

- Do not weld or modify this baseplate or its components. Welding or modification will void the warranty.
- Do not use this document as a basis to design/fabricate a baseplate, as it may not show all parts or structural components.
- We strongly recommend professional installation.
- If the towed vehicle has been in an accident, it must be properly repaired before attaching the baseplate. Do not install the baseplate if any structural frame damage is found.
- The installer must use all bolts and parts supplied. If running changes were made by the vehicle manufacturer after this kit was designed, some bolts or other fasteners may no longer be the correct size. It is the installer's responsibility to verify this kit is securely fastened to the vehicle.
- Use Loctite® Red on all bolts used to secure this baseplate. Torque all bolts to the specifications found at the end of these instructions. Do not over-torque the bolts or failure may occur.
- The installer must inspect the baseplate to ensure adequate clearance, particularly around hoses, air conditioner lines, radiators, etc. or non-warranty failure may result.
- Roadmaster manufactures many styles of baseplates. If your baseplate has removable arms, they must be removed before driving the vehicle, unless the arms can be pinned or padlocked in place. If not secured, the arms could vibrate out.
- Some motorhome chassis have such a tight turning radius that you can damage your motorhome, towed vehicle, tow bar or baseplate while turning sharply. Before getting on the road, test your turning radius in an empty parking lot. Turning too sharply could

result in non-warranty damage to your towing system, motorhome and/or towed vehicle.

- Do not back up with the towed vehicle attached or non-warranty damage will occur to your towing system or vehicles.
- The safety cables must connect the towing vehicle to the towed vehicle frame to frame, with the cables crossed, with enough slack for sharp turns. See cable instructions for proper routing. Failure to do so will result in non-warranty damage and/or the loss of the towed vehicle.
- This kit is designed for use with ROADMASTER tow bars and ROADMASTER adapters only. Using this kit with other brands, without an approved ROADMASTER adapter, may result in non-warranty damage or injury.
- Receiver extensions and out-of-level towing situations of 3 inches or more. This can cause the system to swing much higher and lower, causing excessive strain on the tow bar, baseplate and frame. That can cause the towing system to fail, causing property damage, personal injury or even death. If you must use a receiver extension or drop hitch to tow, it will reduce your receiver's weight capacity by 1/3 to avoid damaging your system. Never use more than one extension and/or drop hitch, as this will void your warranty.
- Every 3,000 miles, the owner must inspect all mounting points for cracks or fatigue, and check the fasteners for proper torque, according to the bolt torque requirements chart on the last page of these instructions.
- The owner must follow the vehicle manufacturer's instructions to prepare the vehicle for towing. Failure to do so may cause severe damage to the vehicle.
- This baseplate is only warranted for the original installation. Installing a used baseplate on another vehicle is not recommended and will void the warranty.



BASEPLATE KIT INSTALLATION INSTRUCTIONS

KIT# 521238-5

01/29/24
KS

ROADMASTER, Inc. 6110 NE 127th Ave. Vancouver, WA 98682 360-896-0407 fax 360-735-9300 www.roadmasterinc.com

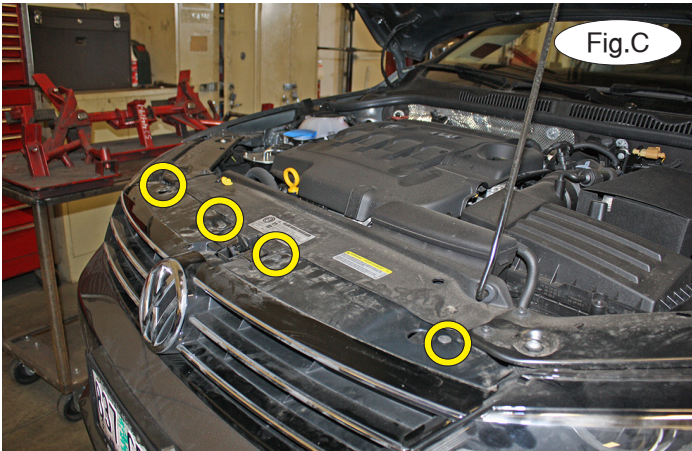

1. **Important:** please use all supplied bolts and parts and read all instructions carefully before beginning this installation. The majority of questions you may have can be answered within the text, and proper installation will ensure safe and secure travel. Now, begin the installation by removing four T25 Torx screws attaching the upper grille to the core support (Fig.C).

2. Pull back on the grille (Fig.D) and remove three T30 Torx bolts attaching the upper fascia to the core support. Figure E shows the location of the center T30 Torx bolt.

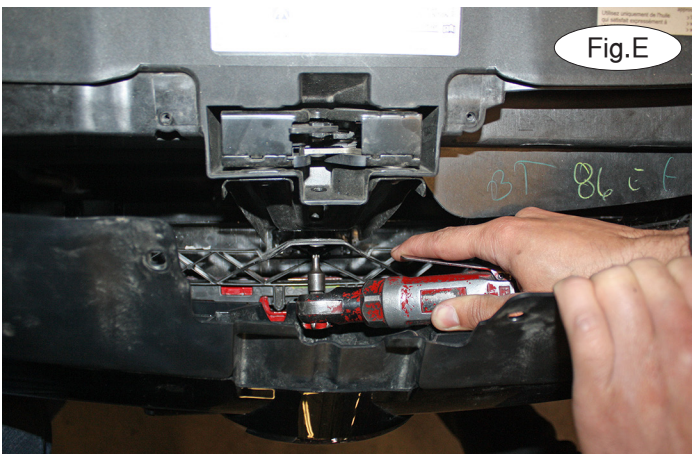

3. On each side, remove four T25 Torx screws attaching the fascia to the fender liner and the fascia to the fender (Fig.F).

4. On each side, remove four T25 Torx screws attaching the bottom of the fascia to the splash shielding (Fig.G).





BASEPLATE KIT INSTALLATION INSTRUCTIONS

KIT# 521238-5

01/29/24
KS

ROADMASTER, Inc. 6110 NE 127th Ave. Vancouver, WA 98682 360-896-0407 fax 360-735-9300 www.roadmasterinc.com

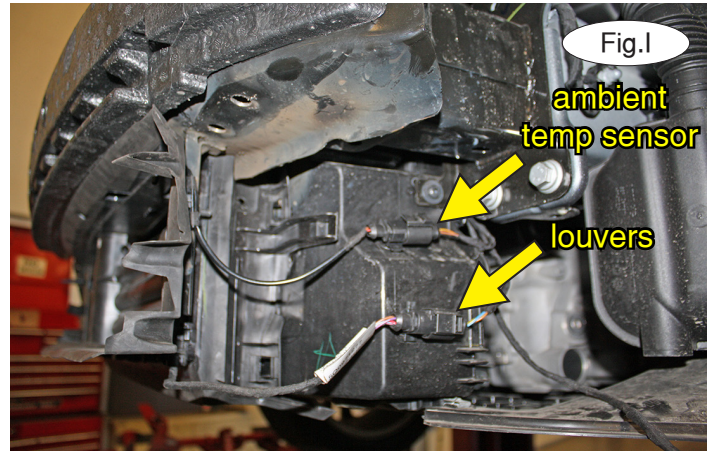

5. Reach in behind the fascia and disconnect the fog lights, if the vehicle is so equipped. Pull out on the corners of the fascia to release the locking strip (Fig.H).

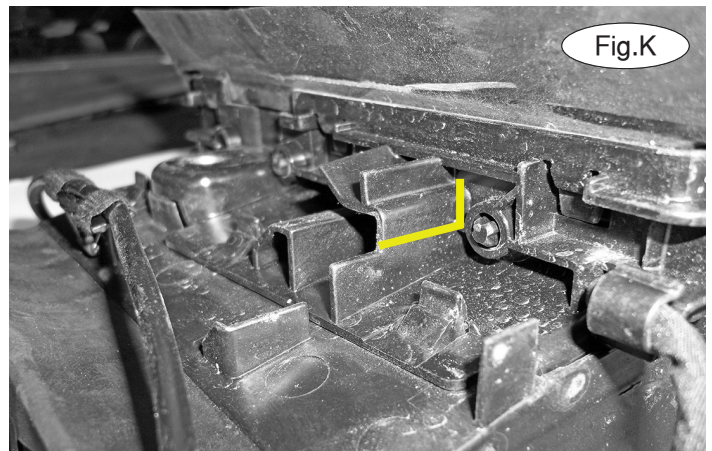

6. On the driver's side, disconnect the ambient temperature sensor and the louvers (Fig.I).

7. On each side, remove one T30 Torx bolt attaching the louvers to the bumper core (Fig.J) and then slide the assembly down to remove it. Place the louvers upside down on a work bench.

8. On each side of the louvers, trim the mounting tab as indicated by yellow lines in Figure K.

9. On each side, MEASURE the louvers as indicated in yellow and then TRIM the louvers as indicated in red (Fig.L).

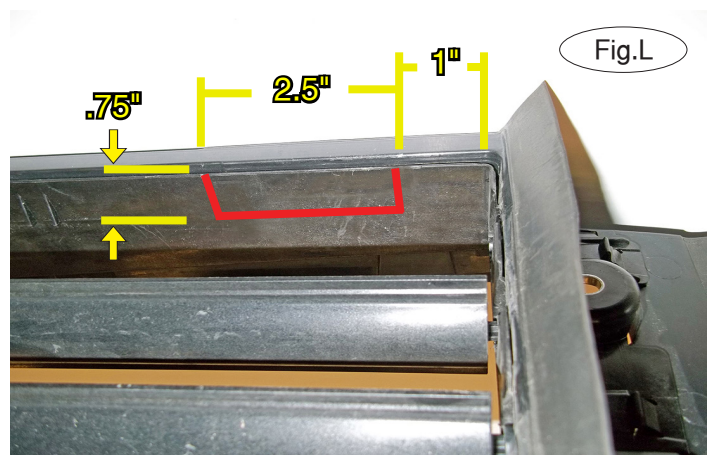



BASEPLATE KIT INSTALLATION INSTRUCTIONS

KIT# 521238-5

01/29/24
KS

ROADMASTER, Inc. 6110 NE 127th Ave. Vancouver, WA 98682 360-896-0407 fax 360-735-9300 www.roadmasterinc.com

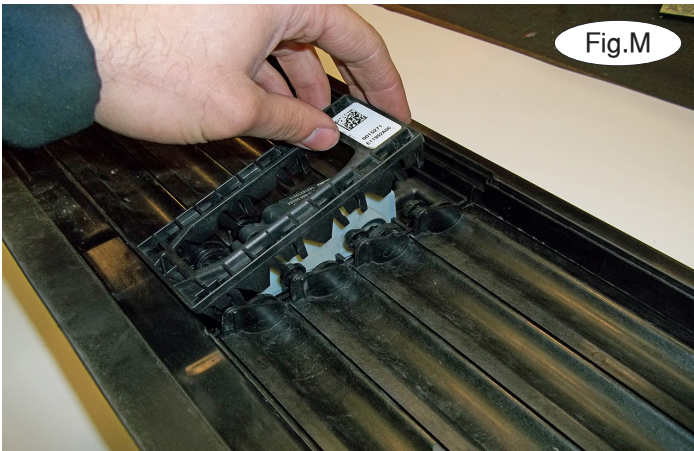

Fig.M



Fig.N

10. Pull up on the plastic linkage to unsnap it from the louvers (Fig.M). Then, use a screwdriver or similar tool to pry between the louver and the center louver housing support to remove the top set of louvers on each side (Fig.N).

11. MEASURE the second set of louvers as indicated in yellow and then TRIM them as indicated in red as shown in Figure O (passenger side) and Figure P (driver's side).

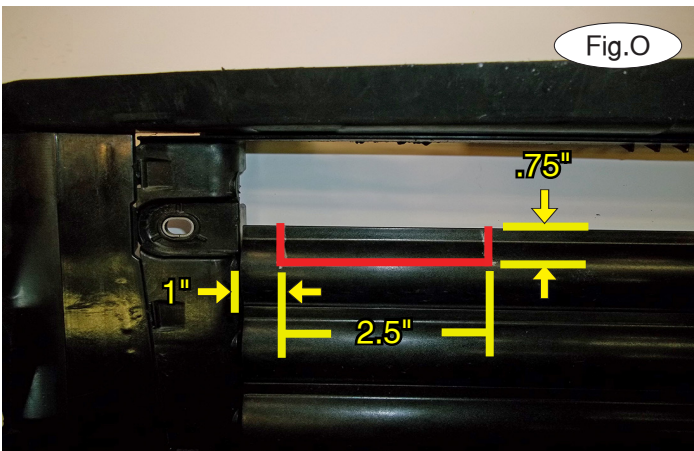

Fig.O

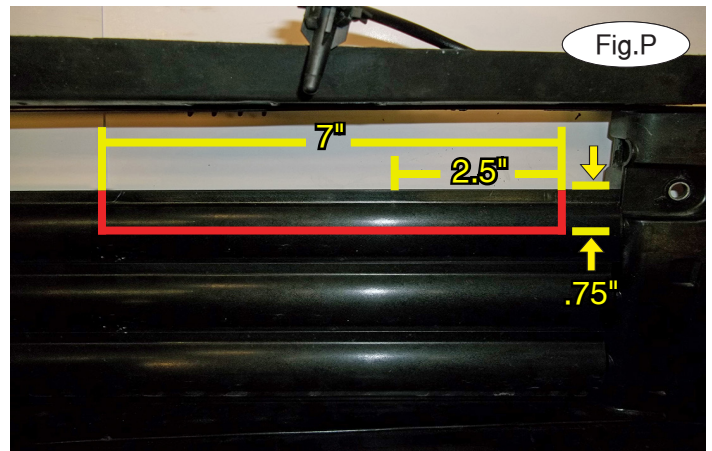

Fig.P

12. Pry the ambient temperature sensor from the hole indicated and then drill a 1/2" hole and remount it as indicated (Fig.Q).

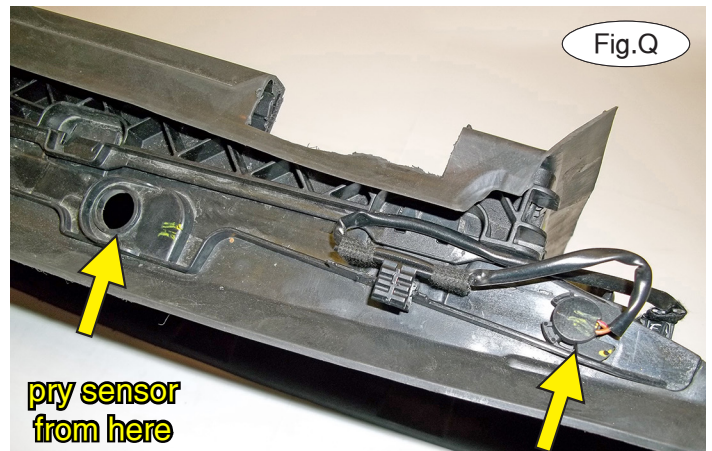

Fig.Q

pry sensor from here

drill 1/2" hole and mount sensor here



BASEPLATE KIT INSTALLATION INSTRUCTIONS

KIT# 521238-5

01/29/24
KS

ROADMASTER, Inc. 6110 NE 127th Ave. Vancouver, WA 98682 360-896-0407 fax 360-735-9300 www.roadmasterinc.com

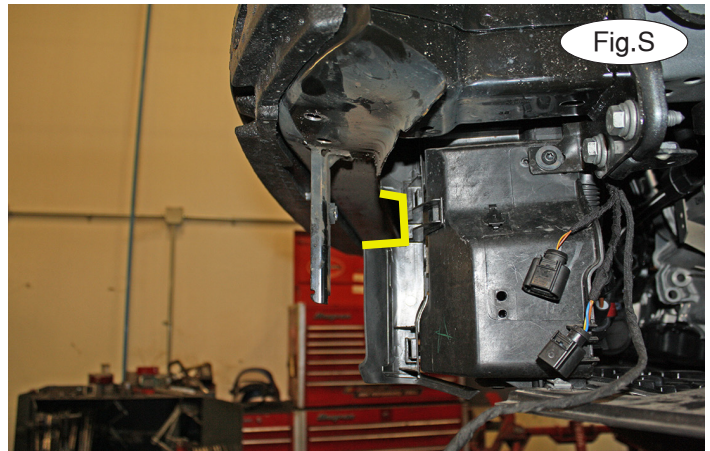

13. Trim the air dams using the yellow lines in Figure R (passenger side) and Figure S (driver's side) as a reference for trimming.

14. On each side, remove two 16mm (head) bolts attaching the bumper to the frame (Fig.T).

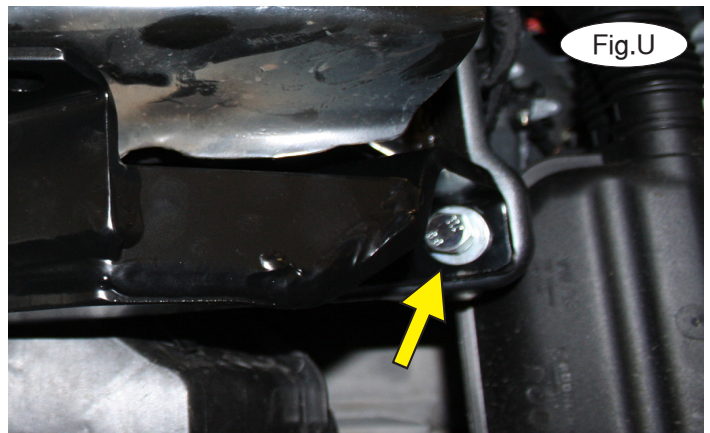
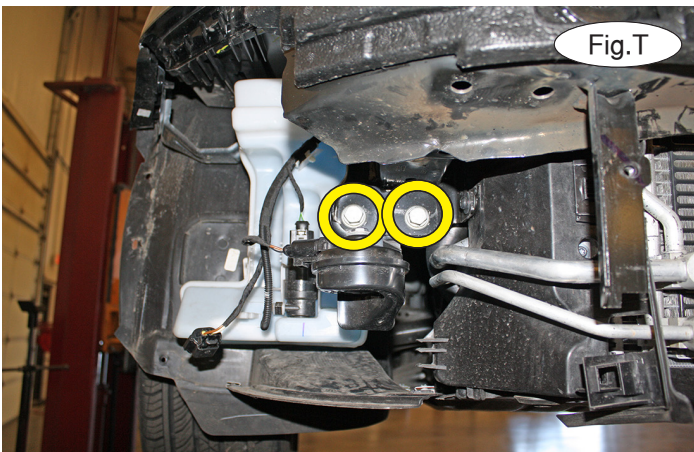

15. Rotate the main receiver brace up under the bumper and behind the lower mounts, aligning the rear holes of the bracket over the two holes you just exposed in the previous step. Clamp it in place. Now, on each side, use a 10mm x 1.5 x 45mm bolt to hold the main receiver brace in place temporarily (Fig.U). *Note:* bend the horn down and out of the way as necessary to complete this procedure on the passenger side. *Note:* ensure proper alignment, as the bolts will receive Loctite® Red and will be torqued at the end of these instructions.

16. Clamp the bracket to the bottom of the bumper (Fig.V). Then, use the forwardmost holes of the bracket as templates and drill a 1/2" hole up through the bumper core. *Note:* ensure that you use a sharp drill bit and a pilot hole due to the hard composition of the bumper core.

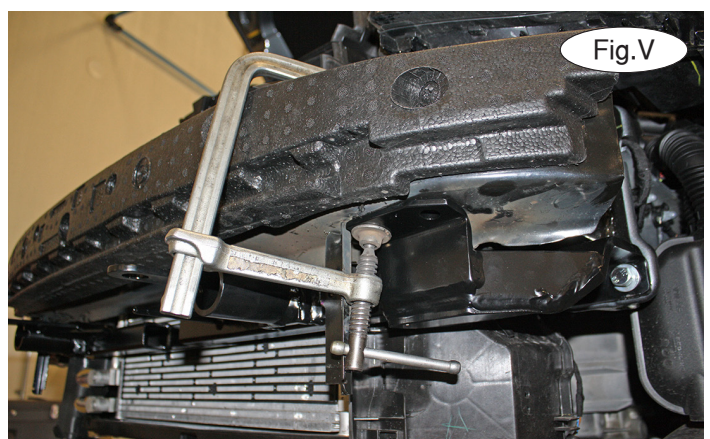



BASEPLATE KIT INSTALLATION INSTRUCTIONS

KIT# 521238-5

01/29/24
KS

ROADMASTER, Inc. 6110 NE 127th Ave. Vancouver, WA 98682 360-896-0407 fax 360-735-9300 www.roadmasterinc.com

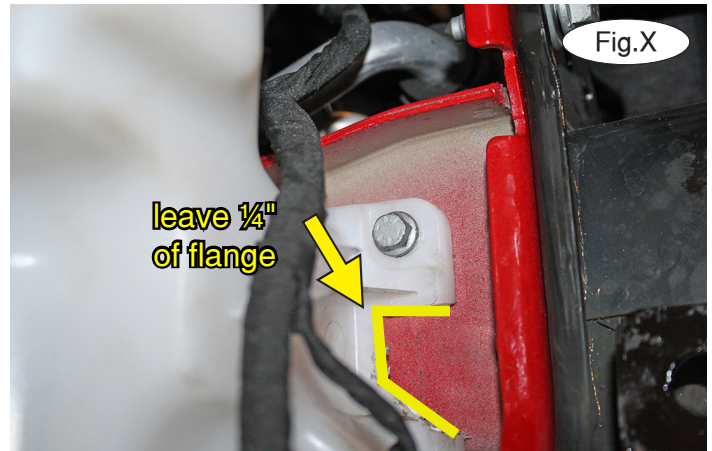
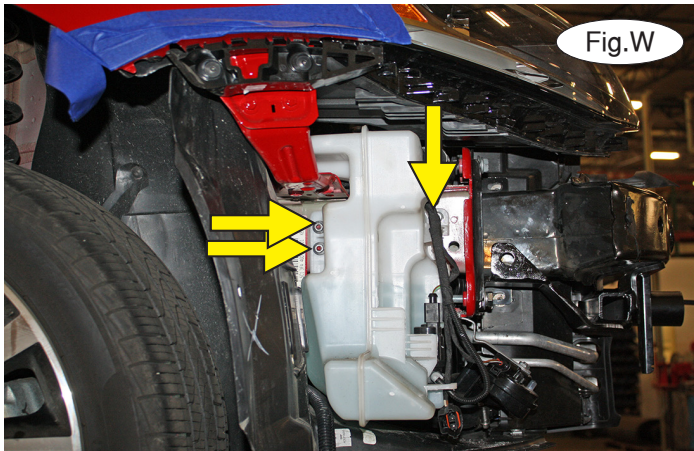

17. On the passenger side only, remove one 10mm (head) bolt and two 10mm nuts attaching the washer bottle to the frame (Fig.W). Then, pull the bottle away from the frame and trim the mount as shown in Figure X and remount the washer bottle. *Note:* leave at least $\frac{1}{4}$ " of flange and use extreme caution to avoid puncturing the body of the bottle.

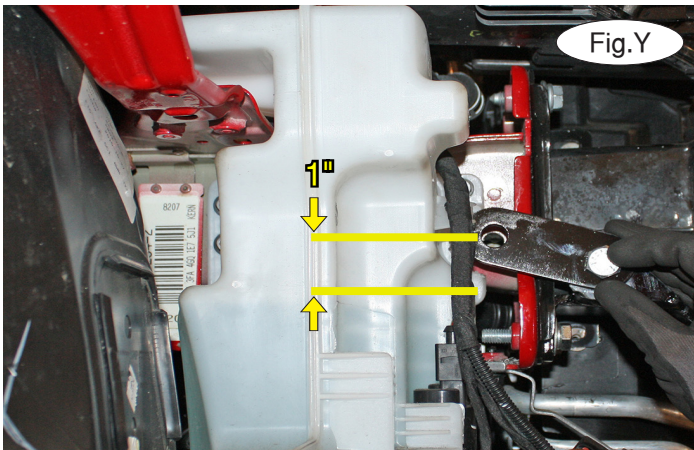

18. On each side, temporarily install the rear support brace to the main receiver brace using the supplied $\frac{1}{2}$ " x $1\frac{1}{4}$ " bolt. Then, angle the rear support brace until it is approximately 1" from center of the mount to the bottom of the frame and mark a hole (Fig.Y). Now, remove the rear support brace and drill a $\frac{1}{2}$ " hole over the mark you made (Fig.Z).

19. Remove the temporary bolts you installed in step 15 and the two remaining 16mm (head) bolts on top of the bumper core, removing the main receiver brace as well.

20. On each side, remove the two T30 Torx bolts attaching the bumper core to the radiator housing (Fig.AA), and let the radiator hang down for now. Then, remove the two 10mm (head) bolts attaching the bumper core to the core support (Fig.BB).





BASEPLATE KIT INSTALLATION INSTRUCTIONS

KIT# 521238-5

01/29/24
KS

ROADMASTER, Inc. 6110 NE 127th Ave. Vancouver, WA 98682 360-896-0407 fax 360-735-9300 www.roadmasterinc.com

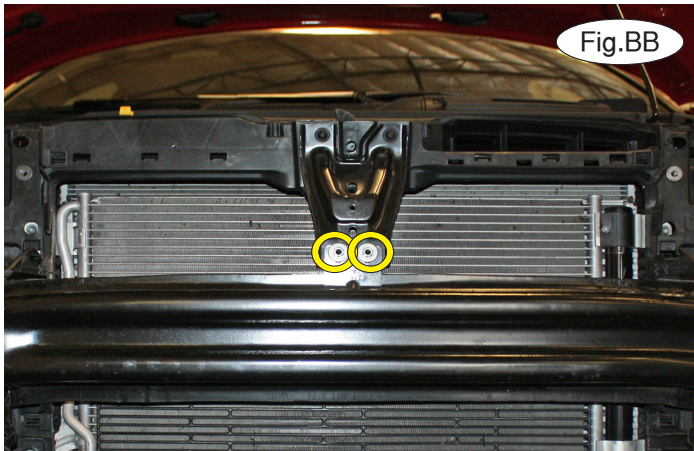

21. On each side, place one of the tab weld nuts inside the bumper core, pushing the air dams out of the way, as necessary and align it over the holes you drilled in the previous step. Now, using one of the $\frac{1}{2}$ " x $2\frac{1}{2}$ " bolt and $\frac{1}{2}$ " lock washer, bolt through the rear support brace, a 1" x .188 wall x $1\frac{1}{4}$ " pipe spacer, and frame, into the tab weld nut (Fig.CC). Fingertighten only for now.

22. Replace the bumper core, and on each side, reinstall the two T30 Torx and two top 16mm (head) bolts. Then, reinstall the two 10mm (head) bolts in the middle. Rotate the main receiver brace under the bumper core once more and install the main receiver brace using the supplied 10mm x 1.5 x 45mm bolts, 10mm lock washers and $\frac{3}{8}$ " flat washers on the lower mounts (Fig.DD).

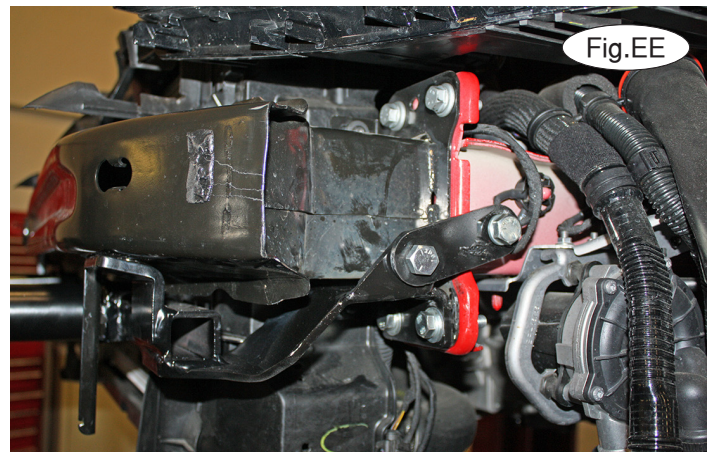

23. On each side, bolt the rear support brace to the main receiver brace using the supplied $\frac{1}{2}$ " x $1\frac{1}{4}$ " bolts, $\frac{1}{2}$ " lock washers and nuts (Fig.EE). Then, using two of the $\frac{1}{2}$ " x $1\frac{1}{4}$ " bolts and $\frac{1}{2}$ " lock washers, bolt up through the main receiver brace and into the bumper core, and finish with $\frac{1}{2}$ " nuts (Fig.FF).



24. Tighten all bolts to the bolt torque requirements found at the end of these instructions. *Note:* use Loctite® Red on all nuts and bolts.



BASEPLATE KIT INSTALLATION INSTRUCTIONS

KIT# 521238-5

01/29/24
KS

ROADMASTER, Inc. 6110 NE 127th Ave. Vancouver, WA 98682 360-896-0407 fax 360-735-9300 www.roadmasterinc.com

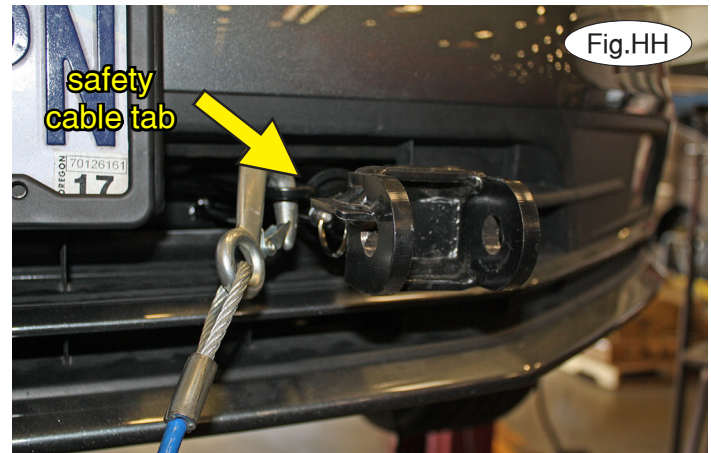

25. Trim the fascia as shown in Figure GG to allow clearance for the main receiver brace. *Note: Due to manufacturing variances, additional trimming may be required.*

26. Reverse steps 1 through 7 to reinstall the fascia and the louvers. *Note: ensure that the louvers fit comfortably and are allowed to open and close freely.*

27. On each side, insert the removable front arm into the front receiver 90 degrees from its final towing position, depressing the spring-loaded pin against the receiver. Twist back 90 degrees until the spring-loaded pin snaps into place in the notch on the receiver, locking the arm into place in its final towing position. **Please note: It is the owner's responsibility to ensure the locking of the pins before towing. Otherwise, failure of the towing system will result. Then, install the tow bar to the baseplate according to the manufacturer's instructions.**

IMPORTANT!

Safety cables are required by law. When towing, connect safety cables to the safety cable tabs illustrated on the first page and in Figure HH. Make certain there is adequate slack in the cables to allow a full turning radius; otherwise, damage will result. If necessary, longer cables or cable extensions are available.

Three options for attaching the wiring plug to the main receiver brace

For six-wire plugs: use the two supplied $\frac{3}{4}$ " self-tapping screws to attach the electrical plug directly to the rods on the front of the main receiver brace.

For four-wire round plugs: attach to the plug mounting plate and then use the two supplied $\frac{3}{4}$ " self-tapping screws to attach the mounting plate to the rods on the front of the main receiver brace.

For four-wire flat plugs: place the plug through the mounting plug plate, and then secure it using the supplied zip tie on the front of the plug (Fig.II). Use the two supplied $\frac{3}{4}$ " self-tapping screws to attach the mounting plate to the rods on the front of the main receiver brace.

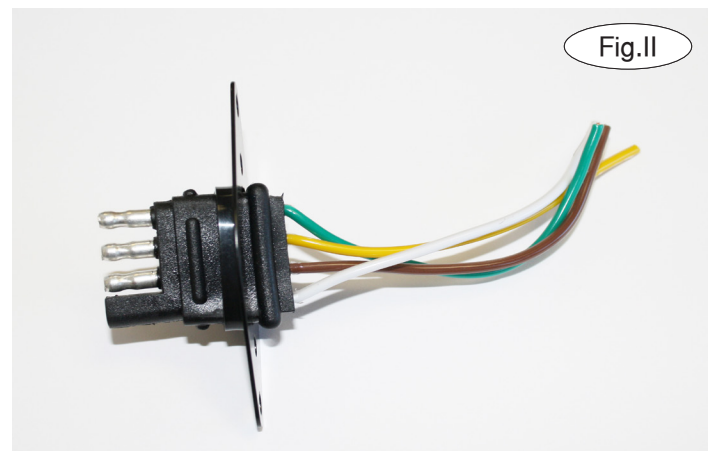



BASEPLATE KIT INSTALLATION INSTRUCTIONS

KIT# 521238-5

01/29/24
KS

ROADMASTER, Inc. 6110 NE 127th Ave. Vancouver, WA 98682 360-896-0407 fax 360-735-9300 www.roadmasterinc.com

BOLT TORQUE REQUIREMENTS

Note: The torque values represented below are intended as general guidelines. Torque requirements for specific applications may vary. Roadmaster does not warrant this information to be accurate for all applications and disclaims all liability for any claims or damages which may result from its use.

STANDARD BOLTS

Thread Size	Grade	Torque
5/16.....	5.....	13 ft./lb.
3/8.....	5.....	23 ft./lb.
7/16.....	5.....	37 ft./lb.
1/2.....	5.....	56 ft./lb.
5/8.....	5.....	150 ft./lb.

METRIC BOLTS

Thread Size	Grade	Plated / Unplated
8mm-1.0.....	8.8.....	20 ft./lb. 18 ft./lb.
8mm-1.25.....	8.8.....	19 ft./lb. 18 ft./lb.
10mm-1.25.....	8.8.....	38 ft./lb. 36 ft./lb.
10mm-1.5.....	8.8.....	37 ft./lb. 35 ft./lb.

METRIC BOLTS

Thread Size	Grade	Plated / Unplated
12mm-1.25.....	8.8.....	70 ft./lb. 65 ft./lb.
12mm-1.5.....	8.8.....	66 ft./lb. 61 ft./lb.
12mm-1.75.....	8.8.....	65 ft./lb. 60 ft./lb.
14mm-2.0.....	8.8.....	104 ft./lb. 97 ft./lb.

All illustrations and specifications contained herein are based on the latest information available at the time of publication approval. ROADMASTER, INC. reserves the right to make changes at any time without notice in material, specification and models or to discontinue models.