



BASEPLATE KIT INSTALLATION INSTRUCTIONS

KIT# 521445-5

02/28/19
KS

ROADMASTER, Inc. 6110 NE 127th Ave. Vancouver, WA 98682 360-896-0407 fax 360-735-9300 www.roadmasterinc.com

*Special tools needed:
plastic pop rivet gun*

Important

Note: this bracket will not accommodate the Guardian rock shield, some models of the Tow Defender, Stowaway or the StowMaster and StowMaster All Terrain tow bars.

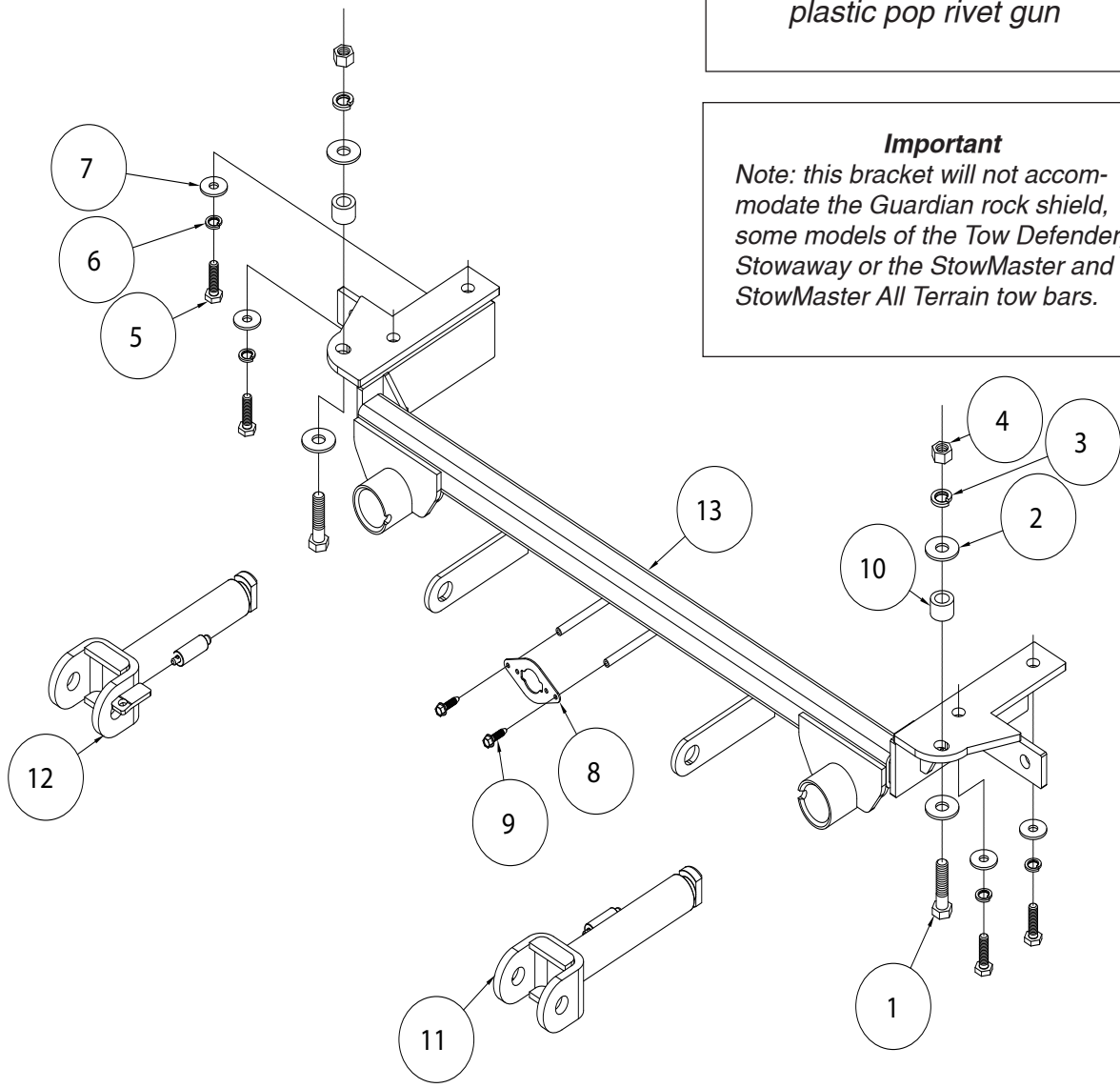

ITEM	QTY	NAME	PART #
1	2	1/2" x 2" BOLT	350097-00
2	4	1/2" FLAT WASHER	350308-00
3	2	1/2" LOCK WASHER	350309-00
4	2	1/2" HEX NUT	350258-00
5	4	10mm x 1.5 x 35mm BOLT	356102-00
6	4	10mm LOCK WASHER	355715-00
7	4	3/8" FLAT WASHER	350304-00
8	1	WIRE PLUG PLATE	A-003801
9	2	#10 x 3/4" SELF TAPPING SCREW	350247-35
10	2	1" O.D x 11/16" SPACER	A-004551
11	1	DRIVER SIDE ARM	C-002383
12	1	PASSENGER SIDE ARM	C-002384
13	1	MAIN RECEIVER	C-002680
14	4	PLASTIC POP RIVET	350431-00

ROADMASTER, INC.



BASEPLATE KIT INSTALLATION INSTRUCTIONS

KIT# 521445-5

02/28/19
KS

ROADMASTER, Inc. 6110 NE 127th Ave. Vancouver, WA 98682 360-896-0407 fax 360-735-9300 www.roadmasterinc.com

This is one of our direct-connect baseplates, which allows the visible front portion to be easily removed from the front of the vehicle (Fig.A and Fig.B). The bracket consists of a main receiver brace, two removable front braces, and a hardware pack.

The main receiver brace mounts to the frame rails and the bumper core. The removable front braces install in the main receiver brace.

Before starting the installation, lay out the kit components in order, as they will be used. This will give you a visual idea of how the components work, and will also confirm that everything is present and accounted for.



IMPORTANT: All baseplates **must** be assembled with all the bolts left loose for final adjustment and positioning (before tightening) unless otherwise instructed. All bolts **must** be torqued for proper strength. If more than one bolt is used per fastening point, the diagram may only show one. Use flat washers over all slotted holes and lock washers on all fasteners.

WARNING

Failure to heed these warnings or follow the installation instructions may result in a voided warranty, loss of towed vehicle, personal injury or death.

- Do not weld or modify this baseplate or its components. Welding or modification will void the warranty.
- Do not use this document as a basis to design/fabricate a baseplate, as it may not show all parts or structural components.
- We strongly recommend professional installation.
- If the towed vehicle has been in an accident, it must be properly repaired before attaching the baseplate. Do not install the baseplate if any structural frame damage is found.
- The installer must use all bolts and parts supplied. If running changes were made by the vehicle manufacturer after this kit was designed, some bolts or other fasteners may no longer be the correct size. It is the installer's responsibility to verify this kit is securely fastened to the vehicle.
- Use Loctite® Red on all bolts used to secure this baseplate. Torque all bolts to the specifications found at the end of these instructions. Do not over-torque the bolts or failure may occur.
- The installer must inspect the baseplate to ensure adequate clearance, particularly around hoses, air conditioner lines, radiators, etc. or non-warranty failure may result.
- Roadmaster manufactures many styles of baseplates. If your baseplate has removable arms, they must be removed before driving the vehicle, unless the arms can be pinned or padlocked in place. If not secured, the arms could vibrate out.
- Some motorhome chassis have such a tight turning radius that you can damage your motorhome, towed vehicle, tow bar or baseplate while turning sharply. Before getting on the road, test your turning radius in an empty parking lot. Turning too sharply could result in non-warranty damage to your towing system, motorhome and/or towed vehicle.
- Do not back up with the towed vehicle attached or non-warranty damage will occur to your towing system or vehicles.
- The safety cables must connect the towing vehicle to the towed vehicle frame to frame, with the cables crossed, with enough slack for sharp turns. See cable instructions for proper routing. Failure to do so will result in non-warranty damage and/or the loss of the towed vehicle.
- This kit is designed for use with ROADMASTER tow bars and ROADMASTER adapters only. Using this kit with other brands, without an approved ROADMASTER adapter, may result in non-warranty damage or injury.
- Receiver extensions and out-of-level towing situations of 3 inches or more. This can cause the system to swing much higher and lower, causing excessive strain on the tow bar, baseplate and frame. That can cause the towing system to fail, causing property damage, personal injury or even death. If you must use a receiver extension or drop hitch to tow, it will reduce your receiver's weight capacity by 1/3 to avoid damaging your system. Never use more than one extension and/or drop hitch, as this will void your warranty.
- Every 3,000 miles, the owner must inspect all mounting points for cracks or fatigue, and check the fasteners for proper torque, according to the bolt torque requirements chart on the last page of these instructions.
- The owner must follow the vehicle manufacturer's instructions to prepare the vehicle for towing. Failure to do so may cause severe damage to the vehicle.
- This baseplate is only warranted for the original installation. Installing a used baseplate on another vehicle is not recommended and will void the warranty.



BASEPLATE KIT INSTALLATION INSTRUCTIONS

KIT# 521445-5

02/28/19
KS

ROADMASTER, Inc. 6110 NE 127th Ave. Vancouver, WA 98682 360-896-0407 fax 360-735-9300 www.roadmasterinc.com



1. **Important:** please use all supplied bolts and parts and read all instructions carefully before beginning this installation. The majority of questions you may have can be answered within the text, and proper installation will ensure safe and secure travel. Now, begin the installation by removing two plastic fasteners attaching the upper fascia to the core support (Fig.C).

2. On each side, remove one 8mm and one 10mm screw and use a pair of side cutters to remove two plastic pop rivets attaching the fender liner to the fascia (Fig.D – passenger side). *Note:* due to manufacturing variances, some vehicles may have plastic fasteners instead. **For '18 and later models:** Proceed to the supplement at the end of these instructions for direction on removing the fascia. **For all other models:** Proceed to the next step.



3. Twist counterclockwise to remove three plastic fasteners attaching the fascia to the core support (Fig.E).

4. On each side, pull out on the lower edge of the fender flair to detach it from the fascia (Fig.F). *Note:* due to manufacturing variances, fender flair may not be present.

5. Pull out on the corners of the fascia to release it from the locking strip (Fig.G). Disconnect the fog lights, if the vehicle is so equipped.

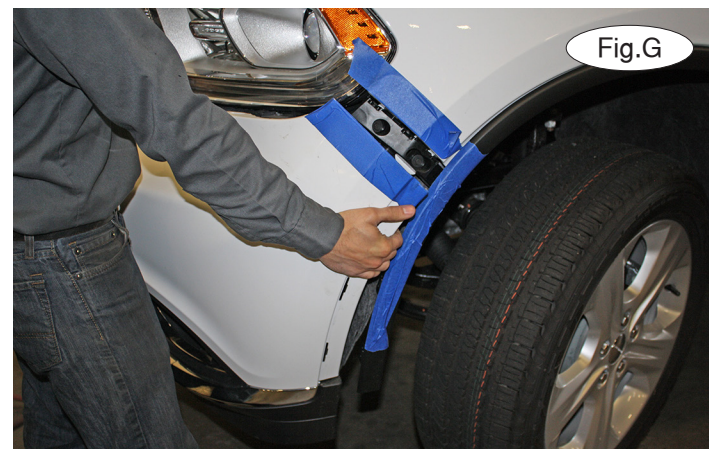



BASEPLATE KIT INSTALLATION INSTRUCTIONS

KIT# 521445-5

02/28/19
KS

ROADMASTER, Inc. 6110 NE 127th Ave. Vancouver, WA 98682 360-896-0407 fax 360-735-9300 www.roadmasterinc.com

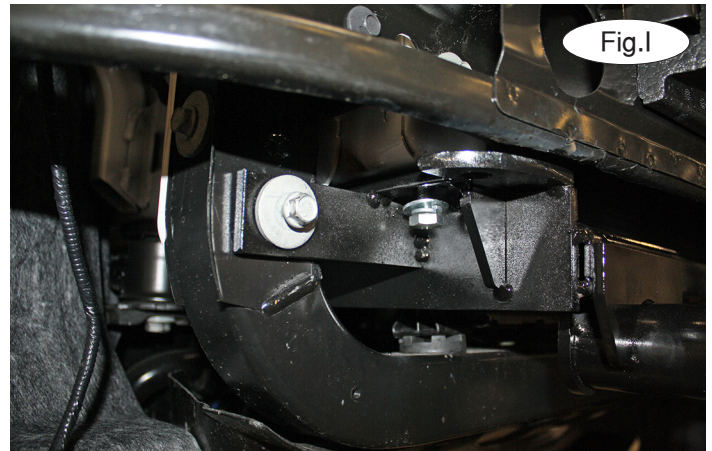
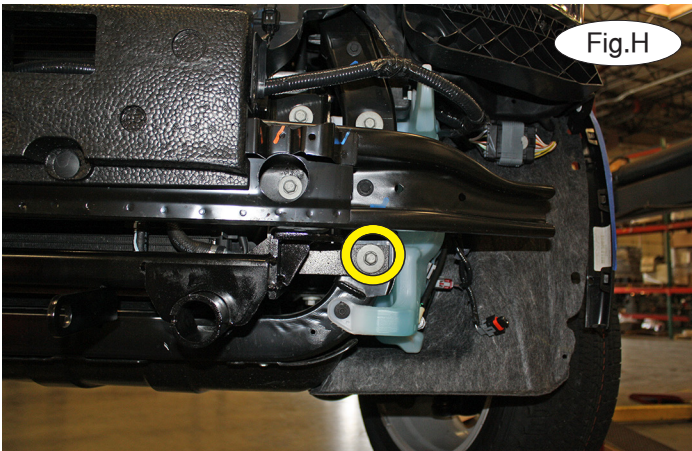

6. On each side, remove one 13mm (head) bolt from the core support (Fig.H).

7. Place the main receiver brace up to the bottom of the frame and replace the 13mm (head) bolts removed in the previous step (Fig.I). *Note:* ensure proper alignment, as the bolts will receive Loctite® Red and will be torqued at the end of these instructions.

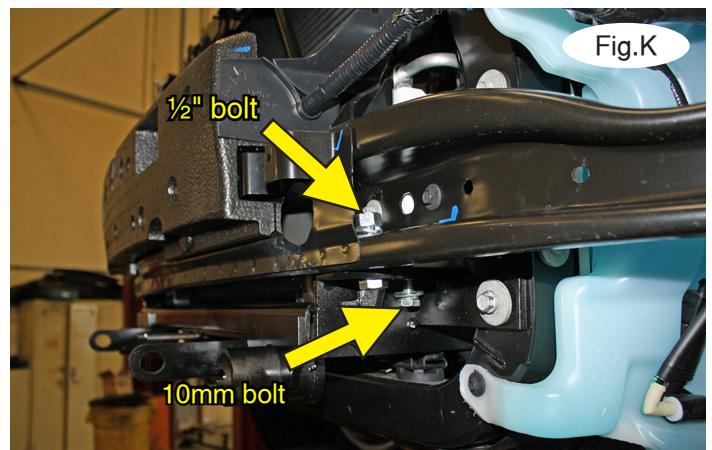
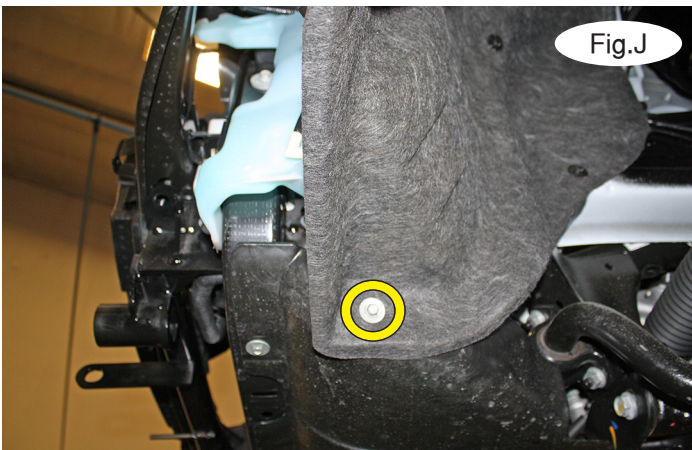

8. On the driver's side only, remove one 10mm (head) bolt attaching the fender to the skid plate (Fig.J).

9. On each side, locate two threaded holes in the bottom of the frame rail and then align the rearmost holes in the bracket with the existing threaded holes. Then, on each side, using the two supplied 10mm x 1.5 x 35mm bolts, a 10mm lock washers and a 3/8" flat washers bolt the main receiver brace into the threaded holes in the bottom of the frame rail.

On each side, place an 11/16" x 1" O.D. x .188 wall pipe spacer between the forwardmost mounting point of the main receiver brace and the bumper core. Using one of the supplied 1/2" x 2" bolts and a 1/2" flat washer, bolt through the main receiver brace, pipe spacer, bumper core and finish with a 1/2" flat washer, lock washer and nut (Fig.K). *Note:* the rearmost mounting point with the 10mm bolt is not visible in Figure K.



10. On the back of the fascia, trim the air dam on each side using the yellow line in Figure L as a guide for trimming.



BASEPLATE KIT INSTALLATION INSTRUCTIONS

KIT# 521445-5

02/28/19
KS

ROADMASTER, Inc. 6110 NE 127th Ave. Vancouver, WA 98682 360-896-0407 fax 360-735-9300 www.roadmasterinc.com

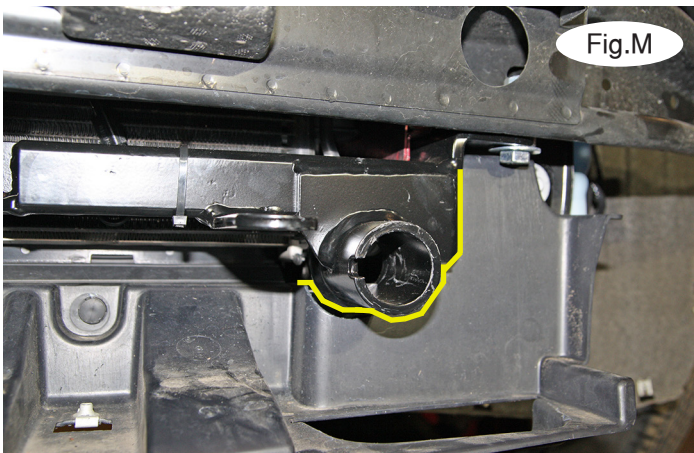

11. Tighten all bolts to the bolt torque requirements found at the end of these instructions. *Note:* use Loctite® Red on all nuts and bolts.

12. Hold the grille over the main receiver brace and mark it for trimming. **For '18 and later models:** Trim the air dam as shown using the yellow lines in Figure M as a reference. **For all other models:** Figure N shows the approximate location for the trimming on the driver's side and for the wiring plug mount to allow clearance for the main receiver brace.

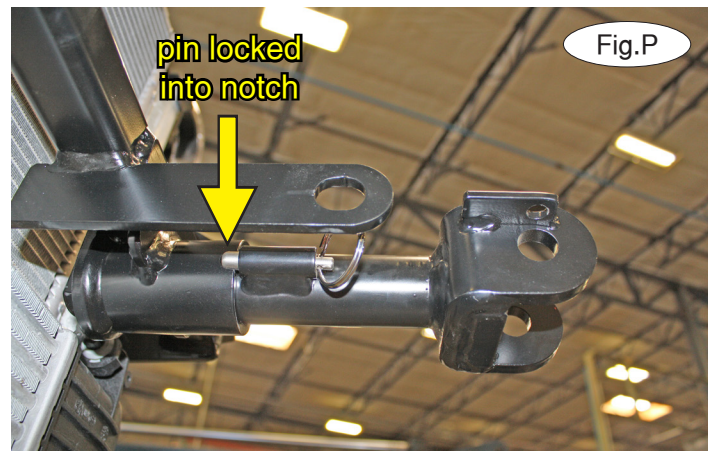
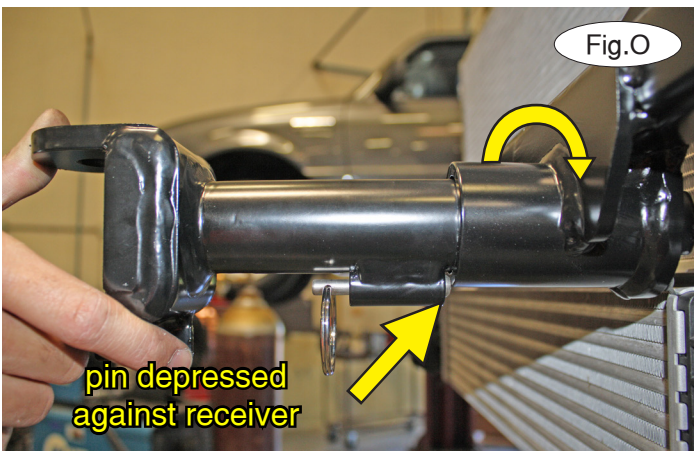

13. Reinstall the fascia, reversing steps 1-4.

14. **Note: the next two images are for illustration purposes only, as your specific application may be slightly different.**

On each side, insert the removable front bracket arm into the front receiver 90 degrees from its final towing position, depressing the spring-loaded pin against the receiver (Fig.O). Now, twist back 90 degrees until the spring-loaded pin snaps into place in the notch on the receiver, locking the arm into place in its final towing position (Fig.P).

Please note: it is the owner's responsibility to ensure the locking of the pins before towing. Otherwise, failure of the towing system will result.

15. Install the tow bar to the mounting bracket according to the manufacturer's instructions.



BASEPLATE KIT INSTALLATION INSTRUCTIONS

KIT# 521445-5

02/28/19
KS

ROADMASTER, Inc. 6110 NE 127th Ave. Vancouver, WA 98682 360-896-0407 fax 360-735-9300 www.roadmasterinc.com

IMPORTANT!

Safety cables are required by law. When towing, connect safety cables to the safety cable tab shown in Figure Q. Make certain there is adequate slack in the cables to allow a full turning radius; otherwise, damage will result. If necessary, longer cables or cable extensions are available.

Note: if the bracket is so equipped, the holes in the alignment tabs which are welded to the arms and main receiver braces are for padlocks only. Under no circumstances should you bolt the alignment tabs together. Bolting the alignment tabs together may result in non-warranty damage to the bracket.

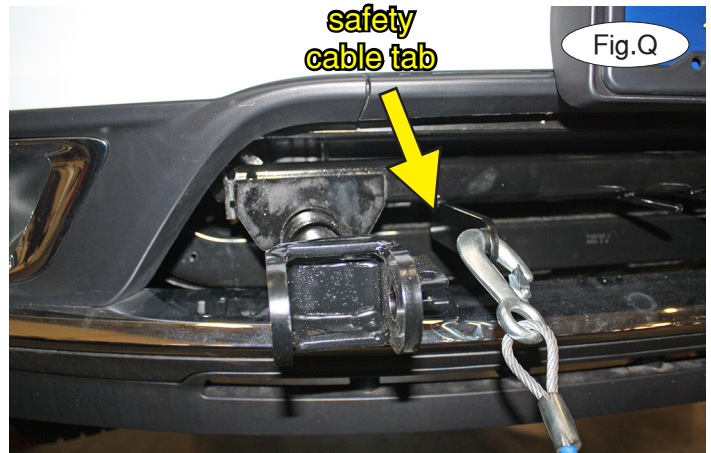

Three options for attaching the wiring plug to the main receiver brace

For six-wire plugs: use the two supplied 3/4" self-tapping screws to attach the electrical plug directly to the rods on the front of the main receiver brace.

For four-wire round plugs: attach to the plug mounting plate and then use the two supplied 3/4" self-tapping screws to attach the mounting plate to the rods on the front of the main receiver brace.

For four-wire flat plugs: place the plug through the mounting plug plate, and then secure it using the supplied zip tie on the front of the plug (Fig.R). Use the two supplied 3/4" self-tapping screws to attach the mounting plate to the rods on the front of the main receiver brace.

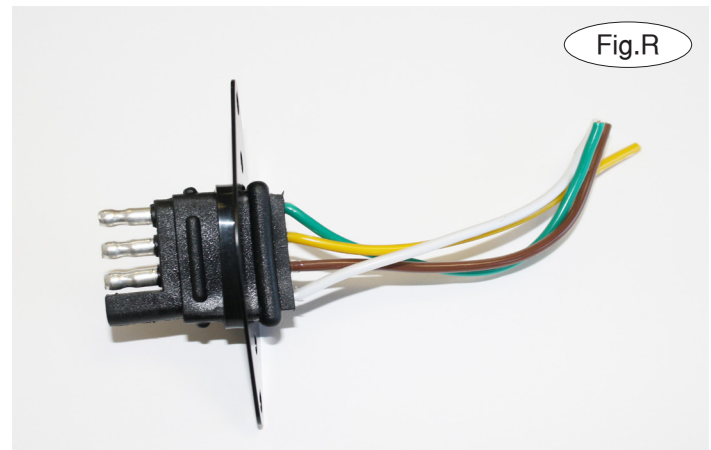

BOLT TORQUE REQUIREMENTS

Note: The torque values represented below are intended as general guidelines. Torque requirements for specific applications may vary. Roadmaster does not warrant this information to be accurate for all applications and disclaims all liability for any claims or damages which may result from its use.

STANDARD BOLTS

Thread Size	Grade	Torque
5/16.....	5.....	13 ft./lb.
3/8.....	5.....	23 ft./lb.
7/16.....	5.....	37 ft./lb.
1/2.....	5.....	56 ft./lb.
5/8.....	5.....	150 ft./lb.

METRIC BOLTS

Thread Size	Grade	Plated / Unplated
8mm-1.0	8.8	20 ft./lb. 18 ft./lb.
8mm-1.25	8.8	19 ft./lb. 18 ft./lb.
10mm-1.25	8.8	38 ft./lb. 36 ft./lb.
10mm-1.5	8.8	37 ft./lb. 35 ft./lb.

METRIC BOLTS

Thread Size	Grade	Plated / Unplated
12mm-1.25	8.8	70 ft./lb. 65 ft./lb.
12mm-1.5	8.8	66 ft./lb. 61 ft./lb.
12mm-1.75	8.8	65 ft./lb. 60 ft./lb.
14mm-2.0	8.8	104 ft./lb. 97 ft./lb.

All illustrations and specifications contained herein are based on the latest information available at the time of publication approval. ROADMASTER, INC. reserves the right to make changes at any time without notice in material, specification and models or to discontinue models.



BASEPLATE KIT INSTALLATION INSTRUCTIONS

KIT# 521445-5

02/28/19
KS

ROADMASTER, Inc. 6110 NE 127th Ave. Vancouver, WA 98682 360-896-0407 fax 360-735-9300 www.roadmasterinc.com

For '18 and later models

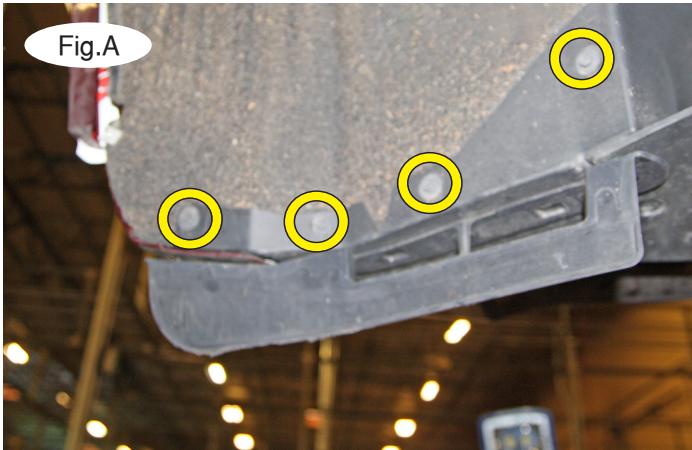

1. On each side, remove four 8mm (head) screws attaching the fender liner to the splash shield (Fig.A).
2. On each side, use a 1/4" drill bit to remove one pop rivet holding the corner of the splash guard to the fascia (Fig.B).
3. On each side, remove five 10mm (head) bolts attaching the splash shield to the fascia (Fig.C – circles). Then, remove three 10mm (head) bolts in the recessed holes (Fig.C – arrows).

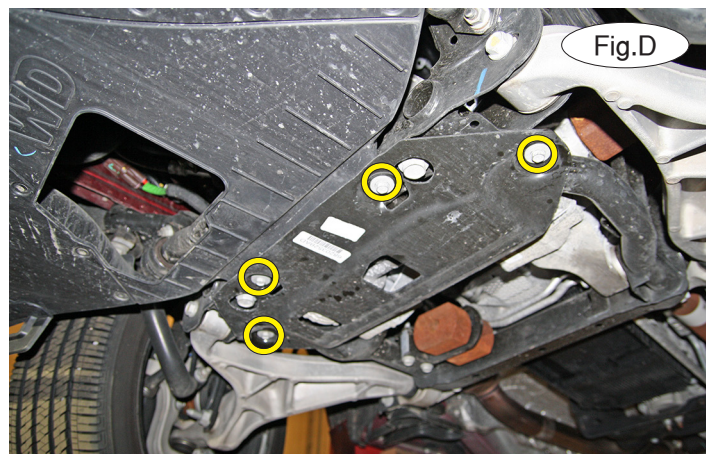

4. Remove four 13mm (head) bolts attaching the skid plate to the subframe (Fig.D). Set it aside for now.
5. Remove one plastic fastener attaching the splash shield to the subframe (Fig.E). Slide it toward the rear of the vehicle to remove it.

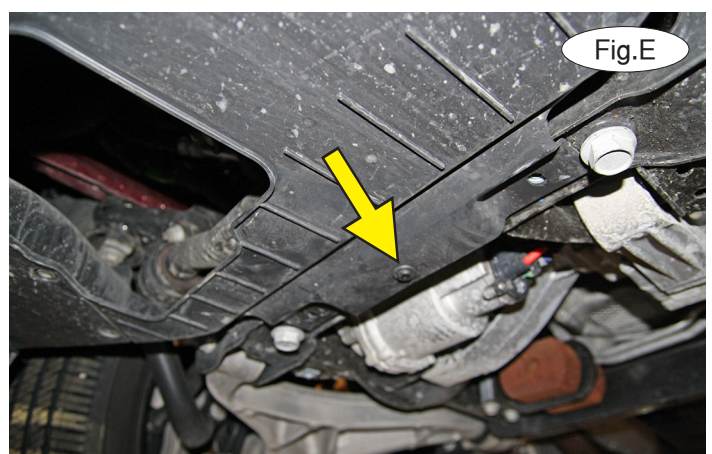



BASEPLATE KIT INSTALLATION INSTRUCTIONS

KIT# 521445-5

02/28/19
KS

ROADMASTER, Inc. 6110 NE 127th Ave. Vancouver, WA 98682 360-896-0407 fax 360-735-9300 www.roadmasterinc.com



6. On each side, lift up to release the grille cover (Fig.F) and then pull out on the corners to release the fascia (Fig.G). Disconnect the wiring harnesses and set the fascia aside for now.

7. Locate three plastic twist fasteners attaching the splash shield to the subframe (Fig.H). Twist each one 90 degrees to remove it.

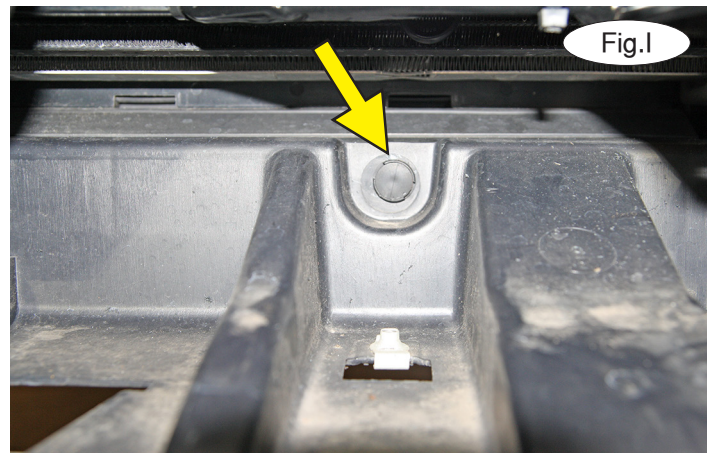

8. On each side, remove a plastic fastener attaching the air dam to the radiator housing (Fig.I - driver's side). *Note: Use caution when removing it to prevent damage to the radiator.*

Now, return to step 7 in the regular instructions to finish the installation.