



BASEPLATE KIT INSTALLATION INSTRUCTIONS

KIT# 521454-5

04/27/23
KS

ROADMASTER, Inc. 6110 NE 127th Ave. Vancouver, WA 98682 360-896-0407 fax 360-735-9300 www.roadmasterinc.com

What You'll Need

Second person for lifting
Ratchet
13mm, 16mm, and 17mm sockets
18mm deep socket
3/4" socket and wrench
17/32" bit and drill

Die grinder or reciprocating saw
Large flat head screwdriver
Panel tool
Torque wrench
Permanent marker
Loctite© Red

*Important
Note: This baseplate will not accom-
modate the Guardian rock shield, some
models of the Tow Defender, or Stow-
Master tow bars.*

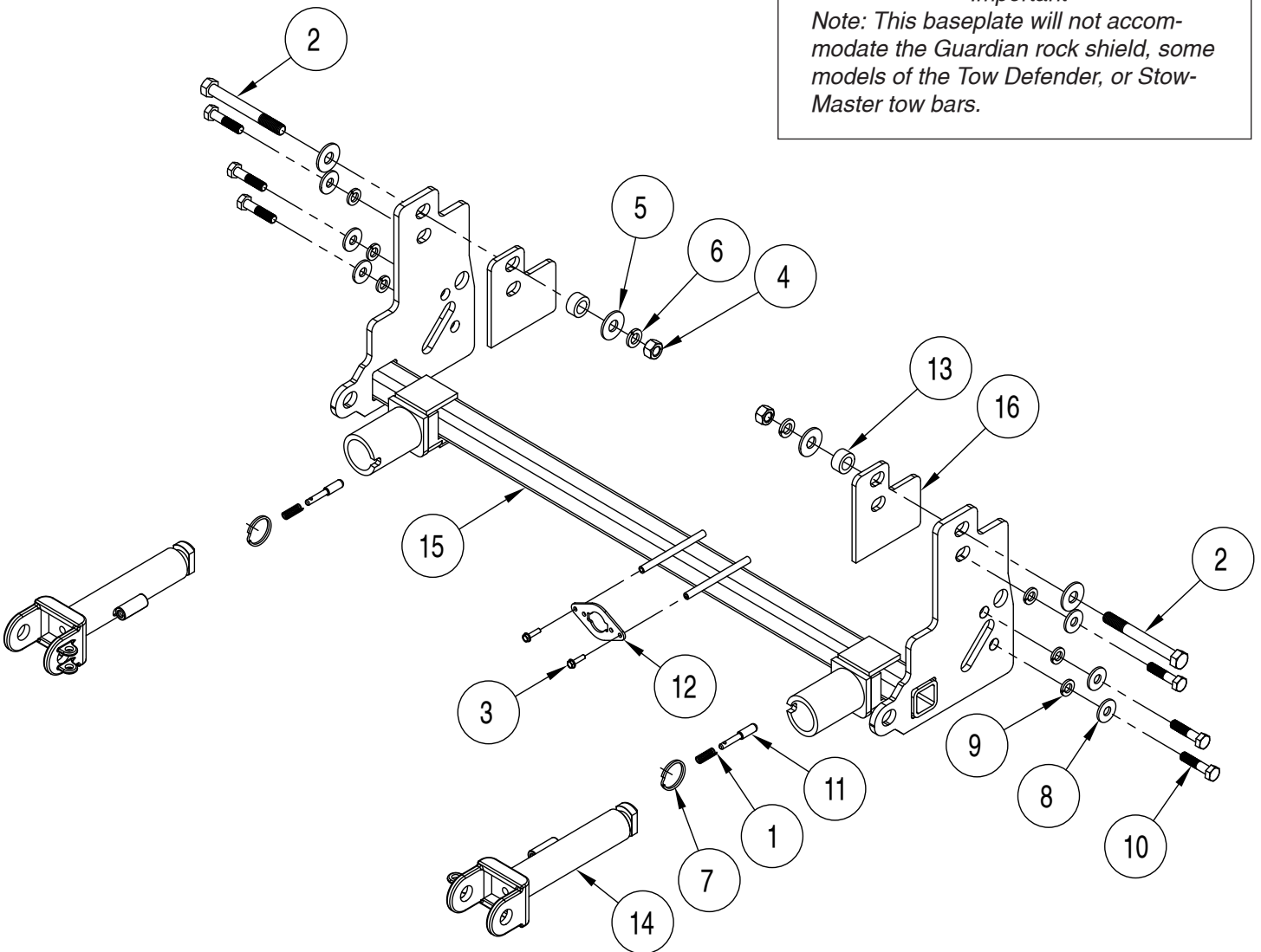

hardware list on next page



BASEPLATE KIT INSTALLATION INSTRUCTIONS

KIT# 521454-5

04/27/23
KS

ROADMASTER, Inc. 6110 NE 127th Ave. Vancouver, WA 98682 360-896-0407 fax 360-735-9300 www.roadmasterinc.com

Hardware List

ITEM	QTY	DESCRIPTION	PART NUMBER
1.....	2	SPRING.....	200146-00
2.....	2	1/2" X 4 1/2" BOLT.....	350106-00
3.....	2	#10 X 3/4" SELF DRILLING SCREW.....	350247-35
4.....	2	1/2" HEX NUT.....	350258-00
5.....	4	1/2" FLAT WASHER.....	350308-00
6.....	2	1/2" LOCK WASHER.....	350309-00
7.....	2	RING.....	350520-00
8.....	6	M10 FLAT WASHER.....	355710-00
9.....	6	M10 LOCK WASHER.....	355715-00
10.....	6	M10 X 1.5 X 40 mm BOLT.....	356103-00
11.....	2	LOCK PIN.....	A000008
12.....	1	WIRE PLUG PLATE.....	A003801
13.....	2	1" O.D. X 0.188" WALL X 1/2" TUBE SPACER.....	A000061
14.....	2	ARM.....	C002383
15.....	1	MAIN RECEIVER.....	C003577
16.....	2	SHIM.....	A006388

IMPORTANT: All baseplates **must** be assembled with all the bolts left loose for final adjustment and positioning (before tightening) unless otherwise instructed. All bolts **must** be torqued for proper strength. If more than one bolt is used per fastening point, the diagram may only show one. Use flat washers over all slotted holes and lock washers on all fasteners.

WARNING

Failure to heed these warnings or follow the installation instructions may result in a voided warranty, loss of towed vehicle, personal injury or death.

- Do not weld or modify this baseplate or its components. Welding or modification will void the warranty.
- Do not use this document as a basis to design/fabricate a baseplate, as it may not show all parts or structural components.
- We strongly recommend professional installation.
- If the towed vehicle has been in an accident, it must be properly repaired before attaching the baseplate. Do not install the baseplate if any structural frame damage is found.
- The installer must use all bolts and parts supplied. If running changes were made by the vehicle manufacturer after this kit was designed, some bolts or other fasteners may no longer be the correct size. It is the installer's responsibility to verify this kit is securely fastened to the vehicle.
- Use Loctite® Red on all bolts used to secure this baseplate. Torque all bolts to the specifications found at the end of these instructions. Do not over-torque the bolts or failure may occur.
- The installer must inspect the baseplate to ensure adequate clearance, particularly around hoses, air conditioner lines, radiators, etc. or non-warranty failure may result.
- Roadmaster manufactures many styles of baseplates. If your baseplate has removable arms, they must be removed before driving the vehicle, unless the arms can be pinned or padlocked in place. If not secured, the arms could vibrate out.
- Some motorhome chassis have such a tight turning radius that you can damage your motorhome, towed vehicle, tow bar or baseplate while turning sharply. Before getting on the road, test your turning radius in an empty parking lot. Turning too sharply could

result in non-warranty damage to your towing system, motorhome and/or towed vehicle.

- Do not back up with the towed vehicle attached or non-warranty damage will occur to your towing system or vehicles.
- The safety cables must connect the towing vehicle to the towed vehicle frame to frame, with the cables crossed, with enough slack for sharp turns. See cable instructions for proper routing. Failure to do so will result in non-warranty damage and/or the loss of the towed vehicle.
- This kit is designed for use with ROADMASTER tow bars and ROADMASTER adapters only. Using this kit with other brands, without an approved ROADMASTER adapter, may result in non-warranty damage or injury.
- Receiver extensions and out-of-level towing situations of 3 inches or more. This can cause the system to swing much higher and lower, causing excessive strain on the tow bar, baseplate and frame. That can cause the towing system to fail, causing property damage, personal injury or even death. If you must use a receiver extension or drop hitch to tow, it will reduce your receiver's weight capacity by 1/3 to avoid damaging your system. Never use more than one extension and/or drop hitch, as this will void your warranty.
- Every 3,000 miles, the owner must inspect all mounting points for cracks or fatigue, and check the fasteners for proper torque, according to the bolt torque requirements chart on the last page of these instructions.
- The owner must follow the vehicle manufacturer's instructions to prepare the vehicle for towing. Failure to do so may cause severe damage to the vehicle.
- This baseplate is only warranted for the original installation. Installing a used baseplate on another vehicle is not recommended and will void the warranty.



BASEPLATE KIT INSTALLATION INSTRUCTIONS

KIT# 521454-5

04/27/23
KS

ROADMASTER, Inc. 6110 NE 127th Ave. Vancouver, WA 98682 360-896-0407 fax 360-735-9300 www.roadmasterinc.com

This is one of our direct-connect series, which allows the visible front portion of the baseplate to be easily removed from the front of the vehicle (Fig.A and Fig.B). This kit consists of a main receiver brace, two removable front braces, and a hardware pack.

The main receiver brace mounts to the frame on each side. The removable front braces install in the main receiver braces.

Before starting the installation, lay out the kit components in order, as they will be used. This will give you a visual idea of how the components work, and will also confirm that everything is present and accounted for.

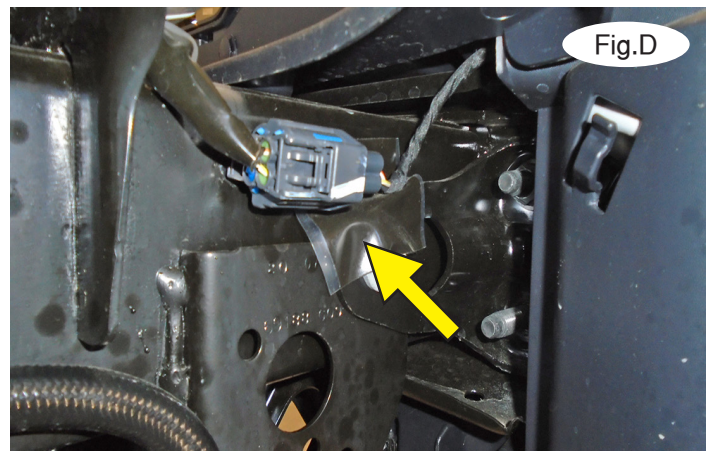

Important: Please use all supplied hardware and read through these instructions carefully before beginning this installation. The majority of questions you may have can be answered within the text, and proper installation will ensure safe and secure travel.

1. *Note:* You will be removing the skidplate and it is heavy. It may be helpful to have a second person assist. On each side, remove two 13mm bolts attaching the metal skidplate to the subframe (Fig.C – driver's side). Set it aside to be trimmed and reinstalled later.

2. *Note:* Before proceeding, please note that for clarification purposes only, we removed the plastic covers on the back of the bumper. On the passenger side, disconnect the fog light harness and remove the protective tape, if the vehicle is so equipped (Fig.D).

3. On each side, remove two 16mm bolts attaching the upper skidplate mount (Fig.E – circles) and one 16mm bolt attaching the bumper stiffener plate to the frame (Fig.E – arrow).

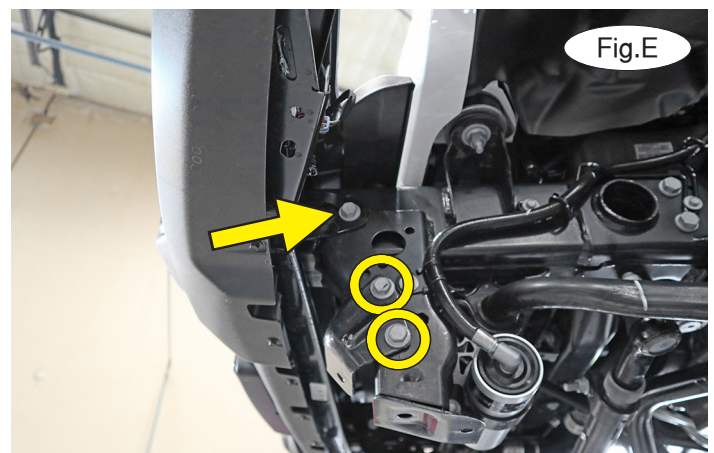



BASEPLATE KIT INSTALLATION INSTRUCTIONS

KIT# 521454-5

04/27/23
KS

ROADMASTER, Inc. 6110 NE 127th Ave. Vancouver, WA 98682 360-896-0407 fax 360-735-9300 www.roadmasterinc.com

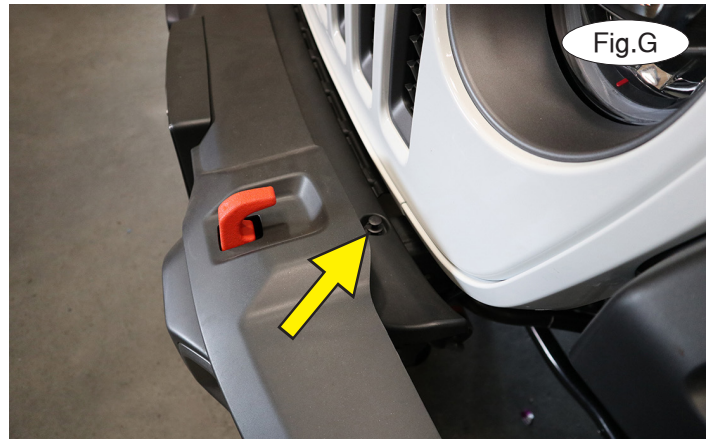
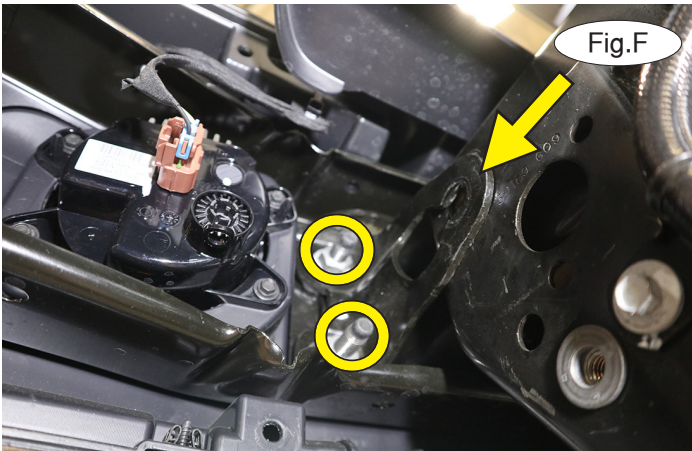

4. On each side, remove four 18mm nuts attaching the bumper to the frame (Fig.F – circles). *Note:* Only the outermost nuts are shown. Then, remove the outer bumper stiffener (Fig.F – arrow). It will not be replaced.

5. On each side, remove one plastic fastener attaching the drip rail to the frame (Fig.G). Pull straight out to remove the bumper and set it aside for now.

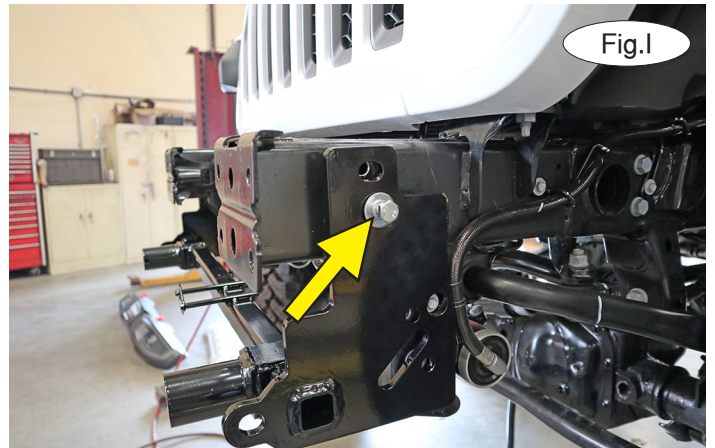
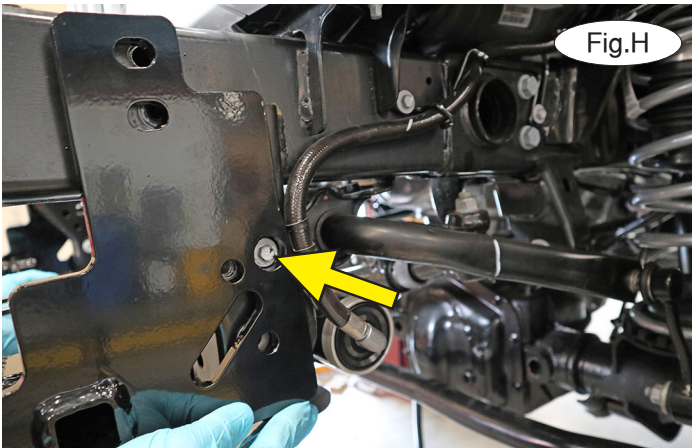

6. For each side, place an M10 lock washer, M10 flat washer and Loctite over an M10 x 1.5 x 40mm bolt. With the assistance of another person, slide the hole at the back of the baseplate over the existing 10mm bolts attaching the hydraulic cable to the frame (Fig.H). *Note:* You may need to use a flathead screwdriver to ease it over the bolt. Then, on each side, loosely thread the prepared bolts into the factory frame stiffener mount and the included shim, if needed (Fig.I). Refer to page 1 for placement of the shim. *Note:* Due to manufacturing variances, the shim may not be needed. If the fit is too tight with it in place, remove the shim completely.

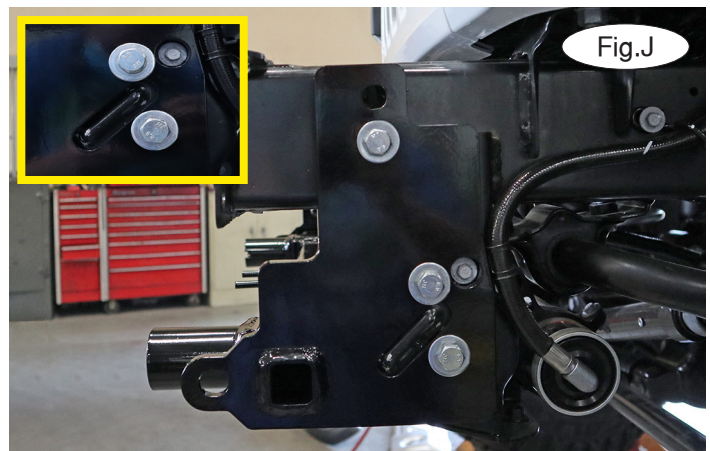

7. Prepare four additional bolts exactly as you did in the previous step. On each side, replace the upper skidplate mount between the baseplate and the frame and loosely install the bolts in the remaining holes (Fig.J). *Note:* If it is properly seated, the raised surface on the upper skidplate mount should nest perfectly into the cutout on the baseplate (Fig.J – inset).



BASEPLATE KIT INSTALLATION INSTRUCTIONS

KIT# 521454-5

04/27/23
KS

ROADMASTER, Inc. 6110 NE 127th Ave. Vancouver, WA 98682 360-896-0407 fax 360-735-9300 www.roadmasterinc.com

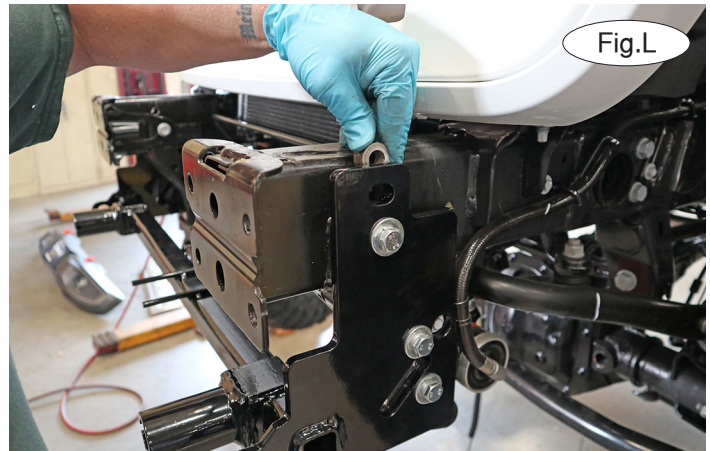
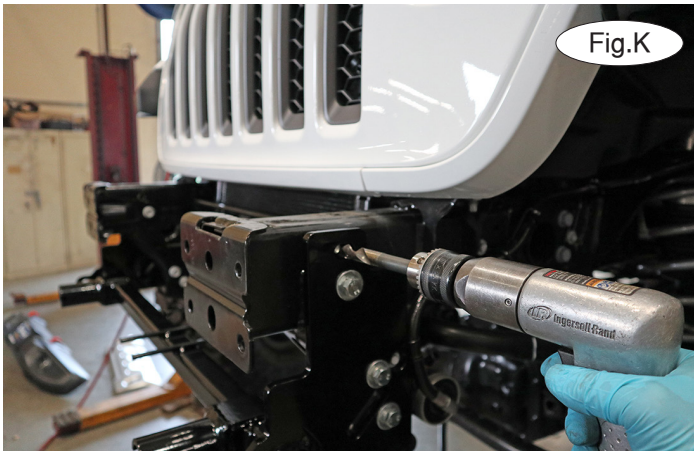

8. Ensure that the baseplate is level to the frame on each side, and then tighten the upper bolt to the torque requirements on each side using a 17mm socket. Then, tighten the bottom two bolts on each side.

9. Using a 17/32" drill bit, enlarge the existing holes in the frame located under the uppermost mount of the baseplate; if, due to manufacturing variances, the holes do not already exist, use the slotted upper mount of the baseplate as a template and drill straight through both sides of the frame rail (Fig.K).

10. On each side, insert the provided 1" O.D. x .188 wall x 1/2" pipe spacer on the outside of the frame (Fig.L). Then, place two 1/2" flat washers over two 1/2" x 4 1/2" bolts and pass the bolts through the upper mounts. Finish the bolts with Loctite, 1/2" flat washers, 1/2" lock washers and 1/2" nuts (Fig.L). Tighten them to the bolt torque requirements.

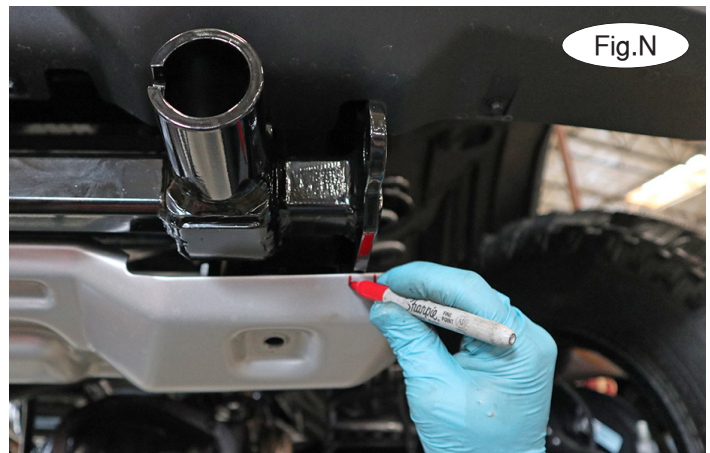
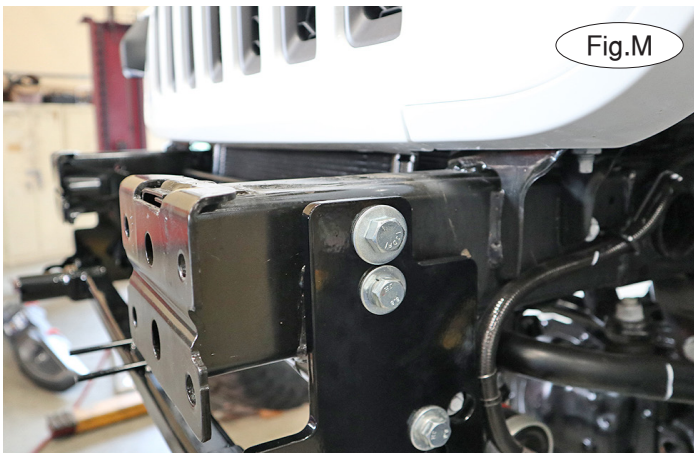

11. Reinstall the bumper and its 18mm hardware, reversing steps 2 through 5.

12. With the assistance of another person, hold the skidplate in place and mark it for trimming (Fig.N). Trim the skidplate and reinstall it by reversing step 1 (Fig.O – next page).



BASEPLATE KIT INSTALLATION INSTRUCTIONS

KIT# 521454-5

04/27/23
KS

ROADMASTER, Inc. 6110 NE 127th Ave. Vancouver, WA 98682 360-896-0407 fax 360-735-9300 www.roadmasterinc.com

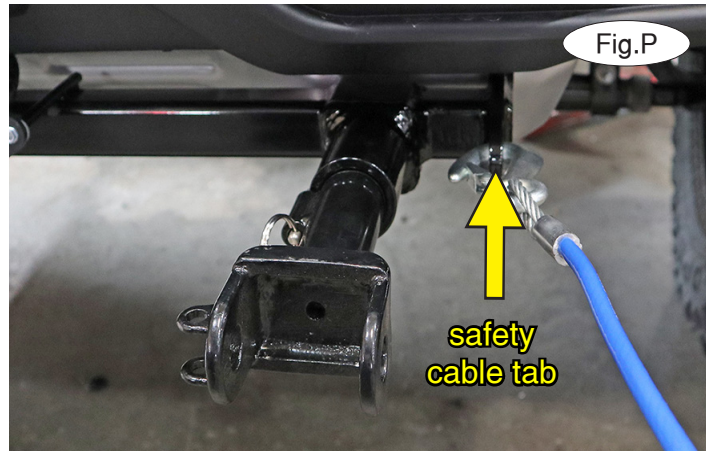

13. On each side, insert the removable front arm into the front receiver 90 degrees from its final towing position, depressing the spring-loaded pin against the receiver. Twist back 90 degrees until the spring-loaded pin snaps into place in the notch on the receiver, locking the arm into place in its final towing position. **Please note: it is the owner's responsibility to ensure the locking of the pins before towing. Otherwise, failure of the towing system will result.**

14. Install the tow bar to the mounting bracket according to the manufacturer's instructions.

IMPORTANT!

Safety cables are required by law. When towing, connect safety cables to the safety cable tabs illustrated on the first page and in Figure P. Make certain there is adequate slack in the cables to allow a full turning radius; otherwise, damage will result. If necessary, longer cables or cable extensions are available.

Three options for attaching the wiring plug to the main receiver brace

For six-wire plugs: use the two supplied 3/4" self-tapping screws to attach the electrical plug directly to the rods on the front of the main receiver brace.

For four-wire round plugs: attach to the plug mounting plate and then use the two supplied 3/4" self-tapping screws to attach the mounting plate to the rods on the front of the main receiver brace.

For four-wire flat plugs: place the plug through the mounting plug plate, and then secure it using the supplied zip tie on the front of the plug (Fig.Q). Use the two supplied 3/4" self-tapping screws to attach the mounting plate to the rods on the front of the main receiver brace.

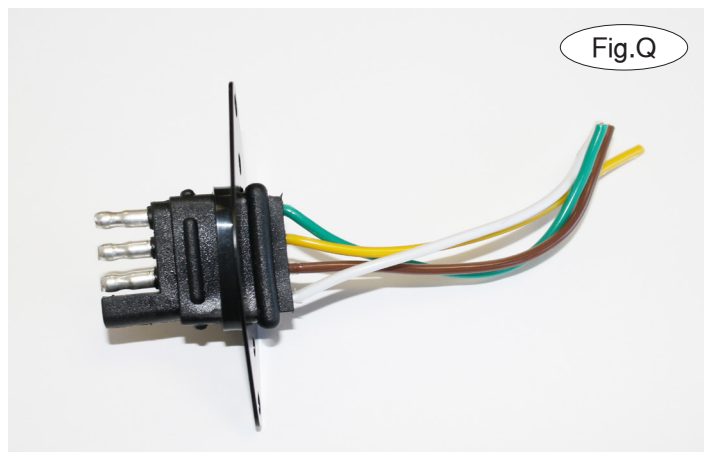

BOLT TORQUE REQUIREMENTS

Note: The torque values represented below are intended as general guidelines. Torque requirements for specific applications may vary. Roadmaster does not warrant this information to be accurate for all applications and disclaims all liability for any claims or damages which may result from its use.

STANDARD BOLTS

Thread Size	Grade	Torque
5/16-18	5	13 ft./lb.
3/8-16	5	23 ft./lb.
7/16-14	5	37 ft./lb.
1/2-13	5	57 ft./lb.
5/8-11	5	112 ft./lb.

METRIC BOLTS

Thread Size	Grade	Torque
6mm-1.0	8.8	6 ft./lb.
8mm-1.0	8.8	18 ft./lb.
8mm-1.25	8.8	16 ft./lb.
10mm-1.25	8.8	36 ft./lb.
10mm-1.5	8.8	31 ft./lb.

METRIC BOLTS

Thread Size	Grade	Torque
12mm-1.25	8.8	64 ft./lb.
12mm-1.5	8.8	60 ft./lb.
12mm-1.75	8.8	55 ft./lb.
14mm-2.0	8.8	88 ft./lb.