



# BASEPLATE KIT INSTALLATION INSTRUCTIONS

**KIT# 521456-5**

12/22/23  
KS

ROADMASTER, Inc. 6110 NE 127th Ave. Vancouver, WA 98682 360-896-0407 fax 360-735-9300 www.roadmasterinc.com

## What You'll Need

Second person for lifting  
Ratchet  
13mm, 16mm, and 18mm sockets  
11mm wrench  
3/4" socket and wrench  
3/8" nut driver  
Drill and long 1/2" bit

Metal cut-off tool or reciprocating saw  
Permanent or paint marker  
Scissors  
Panel tool  
Wire cutters  
Torque wrench  
Loctite© Red

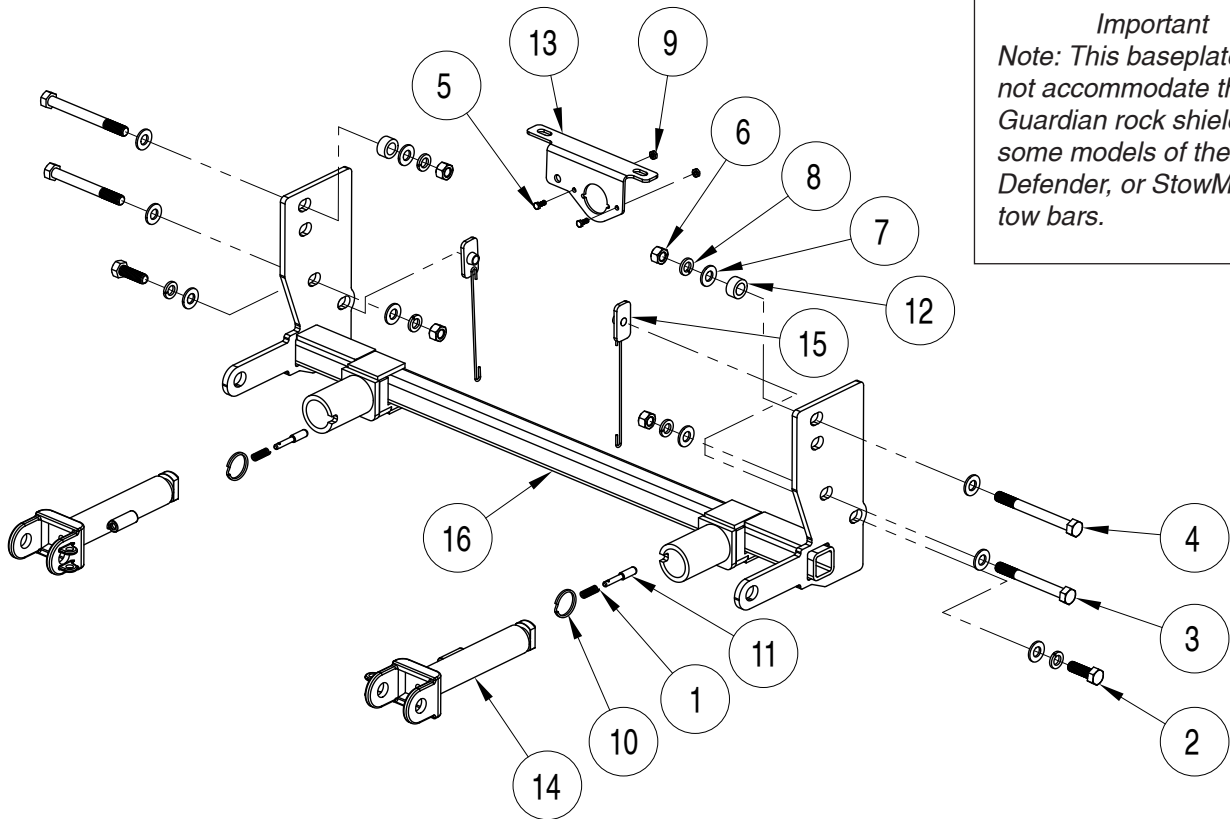

*Important Note: This baseplate will not accommodate the Guardian rock shield, some models of the Tow Defender, or StowMaster tow bars.*

| ITEM          | QTY. | DESCRIPTION  | PART NUMBER |
|---------------|------|--|-------------|
| 1.....2.....  |      | SPRING .....   | 200146-00   |
| 2.....2.....  |      | 1/2" X 1 1/2" BOLT .....                               | 350095-00   |
| 3.....2.....  |      | 1/2" X 4 1/2" BOLT .....                               | 350106-00   |
| 4.....2.....  |      | 1/2" X 5" BOLT .....                                   | 350107-00   |
| 5.....2.....  |      | #10 x 1/2" BOLT .....                                  | 350389-00   |
| 6.....4.....  |      | 1/2" HEX NUT .....                                     | 350258-00   |
| 7.....10..... |      | 1/2" SAE WASHER .....                                  | 350308-20   |
| 8.....6.....  |      | 1/2" LOCK WASHER .....                                 | 350309-00   |
| 9.....2.....  |      | #10 NYLON INSERT LOCK NUT .....                        | 350249-00   |
| 10.....2..... |      | RING .....   | 350520-00   |
| 11.....2..... |      | LOCK PIN .....   | A000008     |
| 12.....2..... |      | 1" O.D. X 0.188" WALL X 1/2" TUBE SPACER .....         | A000061     |
| 13.....1..... |      | WIRE PLUG BRACKET .....                                | B003754     |
| 14.....2..... |      | ARM .....  | C002383     |
| 15.....2..... |      | 3/16" X 1" X 2" THREADED BACKING PLATE W/ 6" ROD ..... | C003563     |
| 16.....1..... |      | MAIN RECEIVER .....                                    | C003566     |



# BASEPLATE KIT INSTALLATION INSTRUCTIONS

**KIT# 521456-5**

12/22/23  
KS

ROADMASTER, Inc. 6110 NE 127th Ave. Vancouver, WA 98682 360-896-0407 fax 360-735-9300 www.roadmasterinc.com

This is one of our direct-connect series, which allows the visible front portion of the baseplate to be easily removed from the front of the vehicle (Fig.A and Fig.B). This kit consists of two main receiver braces, two removable front braces, and a hardware pack.

The main receiver brace mounts to the frame horn on each side. The removable front braces install in the main receiver braces.

Before starting the installation, lay out the kit components in order, as they will be used. This will give you a visual idea of how the components work, and will also confirm that everything is present and accounted for.



**IMPORTANT:** All baseplates **must** be assembled with all the bolts left loose for final adjustment and positioning (before tightening) unless otherwise instructed. All bolts **must** be torqued for proper strength. If more than one bolt is used per fastening point, the diagram may only show one. Use flat washers over all slotted holes and lock washers on all fasteners.

## WARNING

Failure to heed these warnings or follow the installation instructions may result in a voided warranty, loss of towed vehicle, personal injury or death.

- Do not weld or modify this baseplate or its components. Welding or modification will void the warranty.
- Do not use this document as a basis to design/fabricate a baseplate, as it may not show all parts or structural components.
- We strongly recommend professional installation.
- If the towed vehicle has been in an accident, it must be properly repaired before attaching the baseplate. Do not install the baseplate if any structural frame damage is found.
- The installer must use all bolts and parts supplied. If running changes were made by the vehicle manufacturer after this kit was designed, some bolts or other fasteners may no longer be the correct size. It is the installer's responsibility to verify this kit is securely fastened to the vehicle.
- Use Loctite® Red on all bolts used to secure this baseplate. Torque all bolts to the specifications found at the end of these instructions. Do not over-torque the bolts or failure may occur.
- The installer must inspect the baseplate to ensure adequate clearance, particularly around hoses, air conditioner lines, radiators, etc. or non-warranty failure may result.
- Roadmaster manufactures many styles of baseplates. If your baseplate has removable arms, they must be removed before driving the vehicle, unless the arms can be pinned or padlocked in place. If not secured, the arms could vibrate out.
- Some motorhome chassis have such a tight turning radius that you can damage your motorhome, towed vehicle, tow bar or baseplate while turning sharply. Before getting on the road, test your turning radius in an empty parking lot. Turning too sharply could

result in non-warranty damage to your towing system, motorhome and/or towed vehicle.

- Do not back up with the towed vehicle attached or non-warranty damage will occur to your towing system or vehicles.
- The safety cables must connect the towing vehicle to the towed vehicle frame to frame, with the cables crossed, with enough slack for sharp turns. See cable instructions for proper routing. Failure to do so will result in non-warranty damage and/or the loss of the towed vehicle.
- This kit is designed for use with ROADMASTER tow bars and ROADMASTER adapters only. Using this kit with other brands, without an approved ROADMASTER adapter, may result in non-warranty damage or injury.
- Receiver extensions and out-of-level towing situations of 3 inches or more. This can cause the system to swing much higher and lower, causing excessive strain on the tow bar, baseplate and frame. That can cause the towing system to fail, causing property damage, personal injury or even death. If you must use a receiver extension or drop hitch to tow, it will reduce your receiver's weight capacity by 1/3 to avoid damaging your system. Never use more than one extension and/or drop hitch, as this will void your warranty.
- Every 3,000 miles, the owner must inspect all mounting points for cracks or fatigue, and check the fasteners for proper torque, according to the bolt torque requirements chart on the last page of these instructions.
- The owner must follow the vehicle manufacturer's instructions to prepare the vehicle for towing. Failure to do so may cause severe damage to the vehicle.
- This baseplate is only warranted for the original installation. Installing a used baseplate on another vehicle is not recommended and will void the warranty.



# BASEPLATE KIT INSTALLATION INSTRUCTIONS

**KIT# 521456-5**

12/22/23  
KS

ROADMASTER, Inc. 6110 NE 127th Ave. Vancouver, WA 98682 360-896-0407 fax 360-735-9300 www.roadmasterinc.com

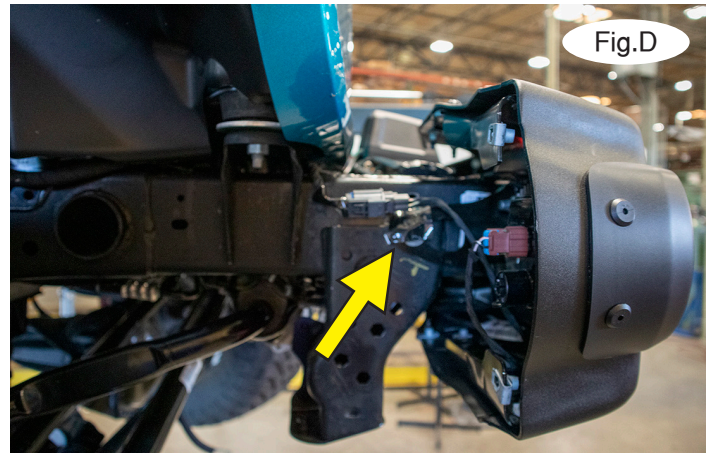
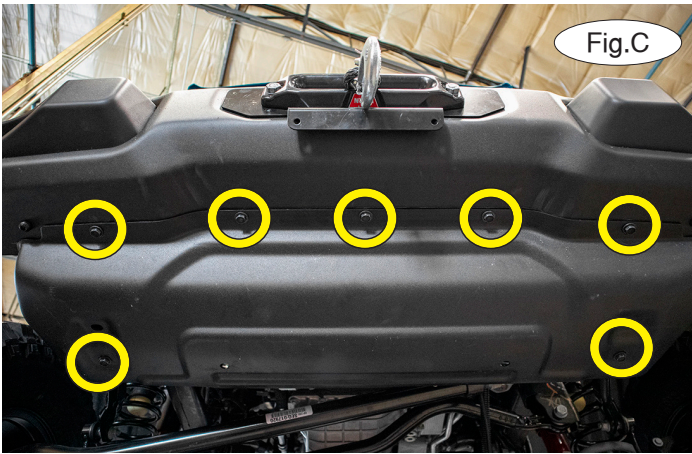

**Important:** Please use all supplied hardware and read through these instructions carefully before beginning this installation. The majority of questions you may have can be answered within the text, and proper installation will ensure safe and secure travel.

1. Note: This kit only fits Wranglers with a factory steel bumper equipped with Warn winch, VR EVO 10-S Winch - 103253. If you do not have a Warn winch, it will require a Mopar winch mounting kit from your Mopar dealer. Note: For clarification purposes, we have removed the ends of the bumper. This is NOT necessary to install the baseplate. Now, begin the installation. Remove seven 13mm bolts attaching the rock guard to the bottom of the bumper and frame (Fig.C). Set it aside for now.

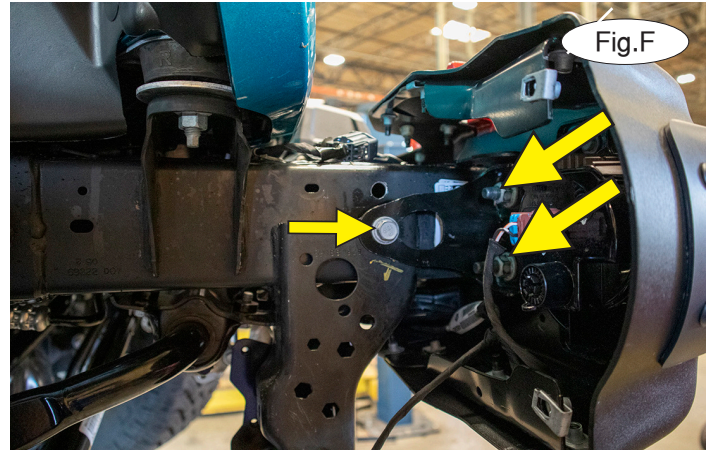
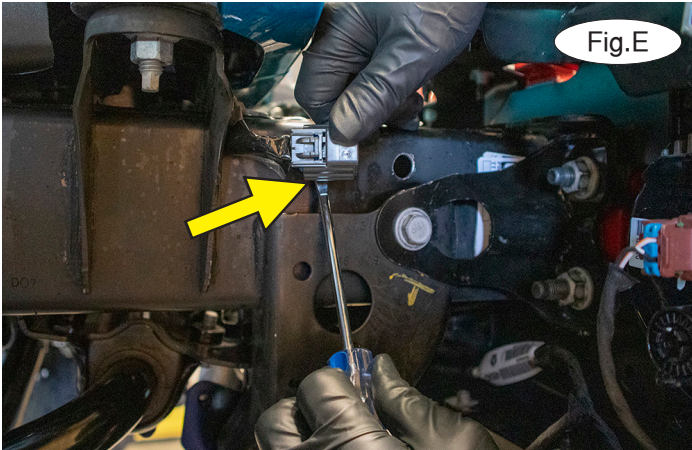

2. On the passenger side, disconnect the foglight wiring harness and remove the protective tape covering the bumper stiffener bolts (Fig.D). Then, remove the second half of the plug from the frame by releasing the Christmas tree clip (Fig.E).

3. On each side, remove one 16mm bolt and two 18mm nuts attaching the bumper and stiffener to the frame (Fig.F – passenger side). Set the stiffener aside. It will not be replaced.

4. On each side, replace the 18mm nuts you removed in step 3. Then, remove two 16mm bolts attaching the lower rock guard mount to the frame (Fig.G). Slide the mount down and set it aside for now.

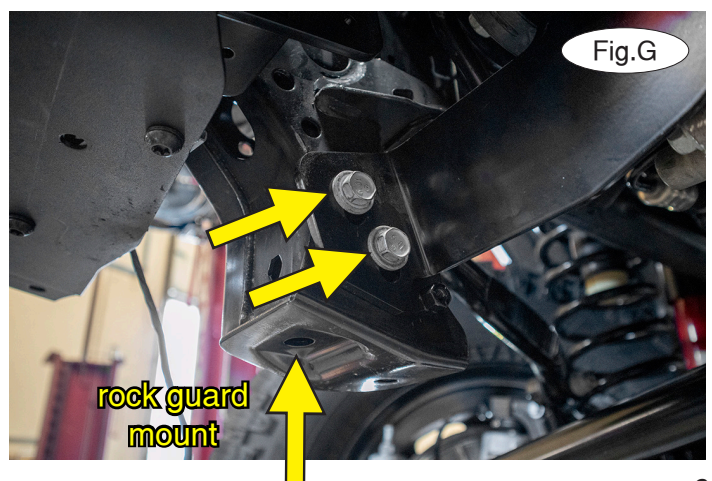



# BASEPLATE KIT INSTALLATION INSTRUCTIONS

**KIT# 521456-5**

12/22/23  
KS

ROADMASTER, Inc. 6110 NE 127th Ave. Vancouver, WA 98682 360-896-0407 fax 360-735-9300 www.roadmasterinc.com

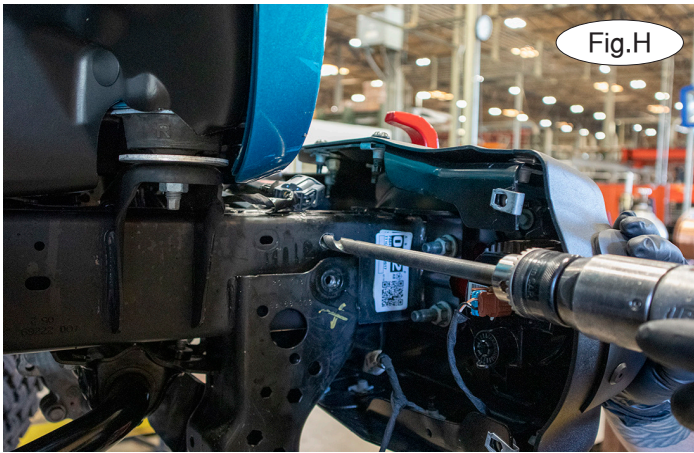

5. On each side, use a long  $\frac{1}{2}$ " drill bit to enlarge the existing hole above the 16mm bolt hole you exposed in step 3 (Fig.H). Drill through both sides of the frame, utilizing the existing hole on the inside of the frame as well. Make certain you use caution and a piece of metal between the drill bit and the winch while drilling.

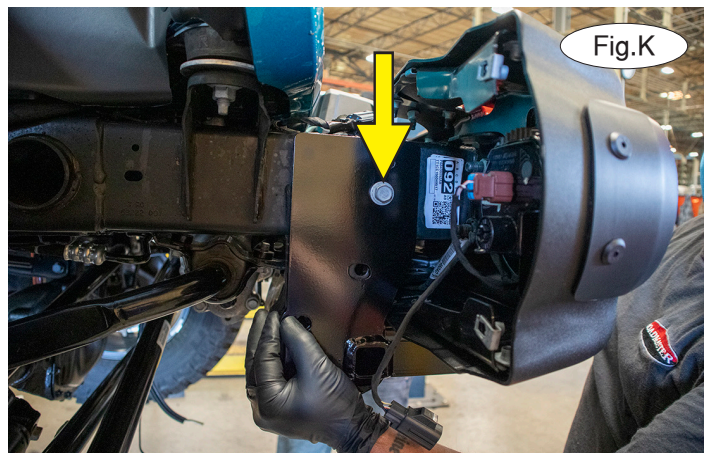

6. Remove any weld spatter or dirt collected on the outside of the frame horns before proceeding (Fig.I – left). Cover with spray paint any spots that expose bare metal. The most important thing is that the surface is smooth and prepped for installing the baseplate (Fig.I – right).

7. With the assistance of a second person, lift the baseplate over the frame horn mounts you smoothed over in step 6 (Fig.J). Align it with the top of the frame rail. Then, loosely replace the 16mm bolt removed in step 3 (Fig.K).

8. Working on the passenger side only, place a small  $\frac{1}{2}$ " flat washer over a  $\frac{1}{2}$ " x 5" bolt and place it through the middle mount of the baseplate (Fig.L) and both sides of the frame. Finish the bolt with a small  $\frac{1}{2}$ " flat washer,  $\frac{1}{2}$ " lock washer and a  $\frac{1}{2}$ " nut.

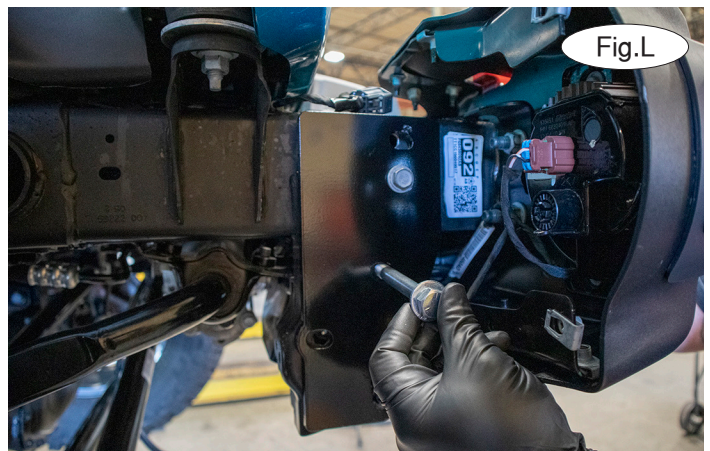



# BASEPLATE KIT INSTALLATION INSTRUCTIONS

**KIT# 521456-5**

12/22/23  
KS

ROADMASTER, Inc. 6110 NE 127th Ave. Vancouver, WA 98682 360-896-0407 fax 360-735-9300 www.roadmasterinc.com

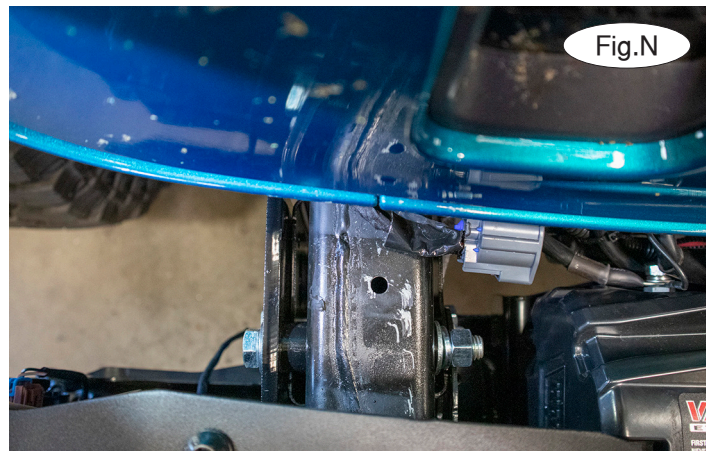

9. Place a  $\frac{1}{2}$ " small flat washer over a  $\frac{1}{2}$ " x  $4\frac{1}{2}$ " bolt. Place a 1" O.D. x .188 wall x  $\frac{1}{2}$ " pipe spacer between the baseplate and the frame (Fig.M). Then, pass the  $4\frac{1}{2}$ " bolt through the baseplate, spacer and frame, and finish the bolt with a  $\frac{1}{2}$ " small flat washer,  $\frac{1}{2}$ " lock washer and  $\frac{1}{2}$ " nut (Fig.N).

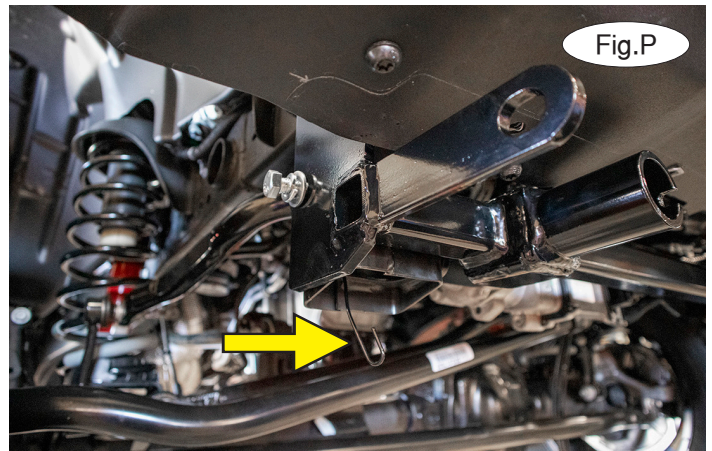

10. Place a  $\frac{1}{2}$ " lock washer and  $\frac{1}{2}$ " small flat washer over a  $\frac{1}{2}$ " x  $1\frac{3}{4}$ " bolt. Insert a 1" x 2" x  $\frac{3}{16}$ " threaded backing plate with rod inside the frame horn and pass the  $1\frac{3}{4}$ " bolt through the remaining lower hole in the baseplate, through the frame, and into the backing plate (Fig.O).

11. Ensure that the baseplate is level and then tighten the bolts in this order: 16mm factory bolt, and then the  $\frac{1}{2}$ " bolts. Then, trim off the rod on the backing plate or bend it into the frame horn (Fig.P). Now, reinstall the lower rock guard mount by reversing step 4.

12. Repeat steps 8 through 11 for the driver's side of the vehicle.

13. Hold the rock guard in place and mark it for trimming to allow clearance for the receivers and the safety cable tabs. Figure Q shows the finished trimming.

Then, reinstall the rock guard by reversing steps 1 and 2. If you are using our provided wiring plug, you will need to drill a minimum 1" diameter hole for the plug and use the center bolt and the bolt just to the right of center to mount the bracket. Use the included #10 x  $\frac{1}{2}$ " bolts and nuts to mount the plug to the bracket (Fig.R – next page).





# BASEPLATE KIT INSTALLATION INSTRUCTIONS

**KIT# 521456-5**

12/22/23  
KS

ROADMASTER, Inc. 6110 NE 127th Ave. Vancouver, WA 98682 360-896-0407 fax 360-735-9300 www.roadmasterinc.com

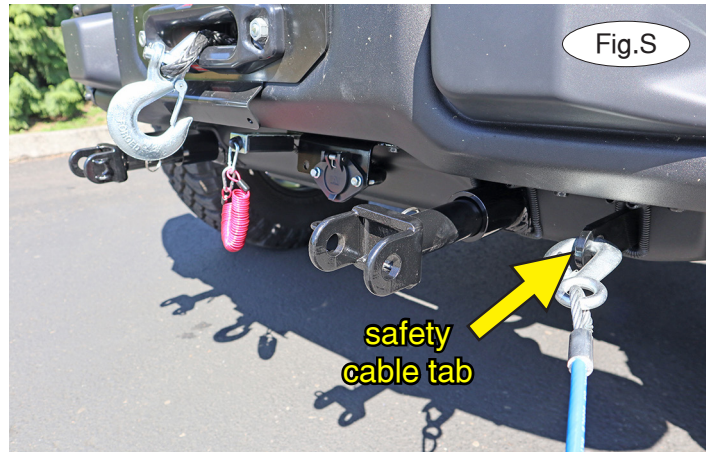

14. On each side, insert the removable front arm into the front receiver 90 degrees from its final towing position, depressing the spring-loaded pin against the receiver. Twist back 90 degrees until the spring-loaded pin snaps into place in the notch on the receiver, locking the arm into place in its final towing position. **Please note: It is the owner's responsibility to ensure the locking of the pins before towing. Otherwise, failure of the towing system will result.**

15. Install the tow bar to the mounting bracket according to the manufacturer's instructions.

### IMPORTANT!

**Safety cables are required by law. When towing, connect safety cables to the safety cable tabs illustrated on the first page and in Figure S. Make certain there is adequate slack in the cables to allow a full turning radius; otherwise, damage will result. If necessary, longer cables or cable extensions are available.**

### Three options for attaching the wiring plug to the main receiver brace

**For six-wire plugs:** Use the two supplied 3/4" self-tapping screws to attach the electrical plug directly to the rods on the front of the main receiver brace.

**For four-wire round plugs:** Attach to the plug mounting plate and then use the two supplied 3/4" self-tapping screws to attach the mounting plate to the rods on the front of the main receiver brace.

**For four-wire flat plugs:** Place the plug through the mounting plug plate, and then secure it using the supplied zip tie on the front of the plug (Fig.T). Use the two supplied 3/4" self-tapping screws to attach the mounting plate to the rods on the front of the main receiver brace.

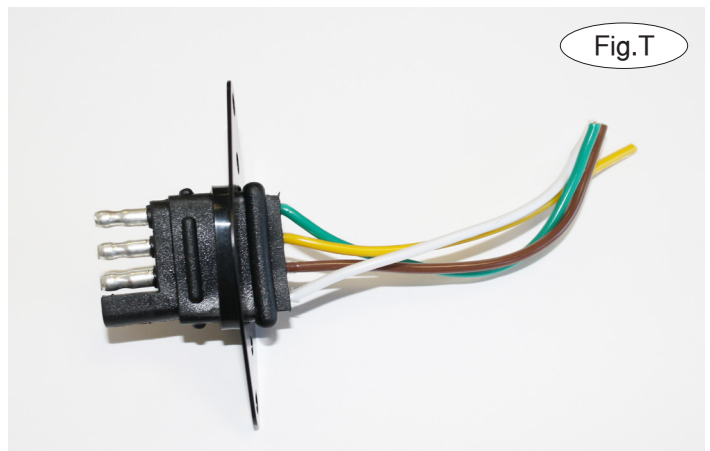

### BOLT TORQUE REQUIREMENTS

Note: The torque values represented below are intended as general guidelines. Torque requirements for specific applications may vary. Roadmaster does not warrant this information to be accurate for all applications and disclaims all liability for any claims or damages which may result from its use.

#### STANDARD BOLTS

| Thread Size | Grade | Torque      |
|-------------|-------|-------------|
| 5/16-18     | 5     | 13 ft./lb.  |
| 3/8-16      | 5     | 23 ft./lb.  |
| 7/16-14     | 5     | 37 ft./lb.  |
| 1/2-13      | 5     | 57 ft./lb.  |
| 5/8-11      | 5     | 112 ft./lb. |

#### METRIC BOLTS

| Thread Size | Grade | Torque     |
|-------------|-------|------------|
| 6mm-1.0     | 8.8   | 6 ft./lb.  |
| 8mm-1.0     | 8.8   | 18 ft./lb. |
| 8mm-1.25    | 8.8   | 16 ft./lb. |
| 10mm-1.25   | 8.8   | 36 ft./lb. |
| 10mm-1.5    | 8.8   | 31 ft./lb. |

#### METRIC BOLTS

| Thread Size | Grade | Torque     |
|-------------|-------|------------|
| 12mm-1.25   | 8.8   | 64 ft./lb. |
| 12mm-1.5    | 8.8   | 60 ft./lb. |
| 12mm-1.75   | 8.8   | 55 ft./lb. |
| 14mm-2.0    | 8.8   | 88 ft./lb. |