



BASEPLATE KIT INSTALLATION INSTRUCTIONS

KIT# 521458-4

08/24
KS

ROADMASTER, Inc. 6110 NE 127th Ave. Vancouver, WA 98682 360-896-0407 fax 360-735-9300 www.roadmasterinc.com

Second person for lifting
Ratchet
8mm, 10mm, 16mm short sockets
30mm wrench
10mm deep socket
3/4" socket and wrench

What You'll Need

T40 driver
Panel tool
Needlenose pliers

1 1/2" hole saw
Cutoff wheel
Permanent or paint marker
Shears or utility knife
Torque wrench
Loctite© Red

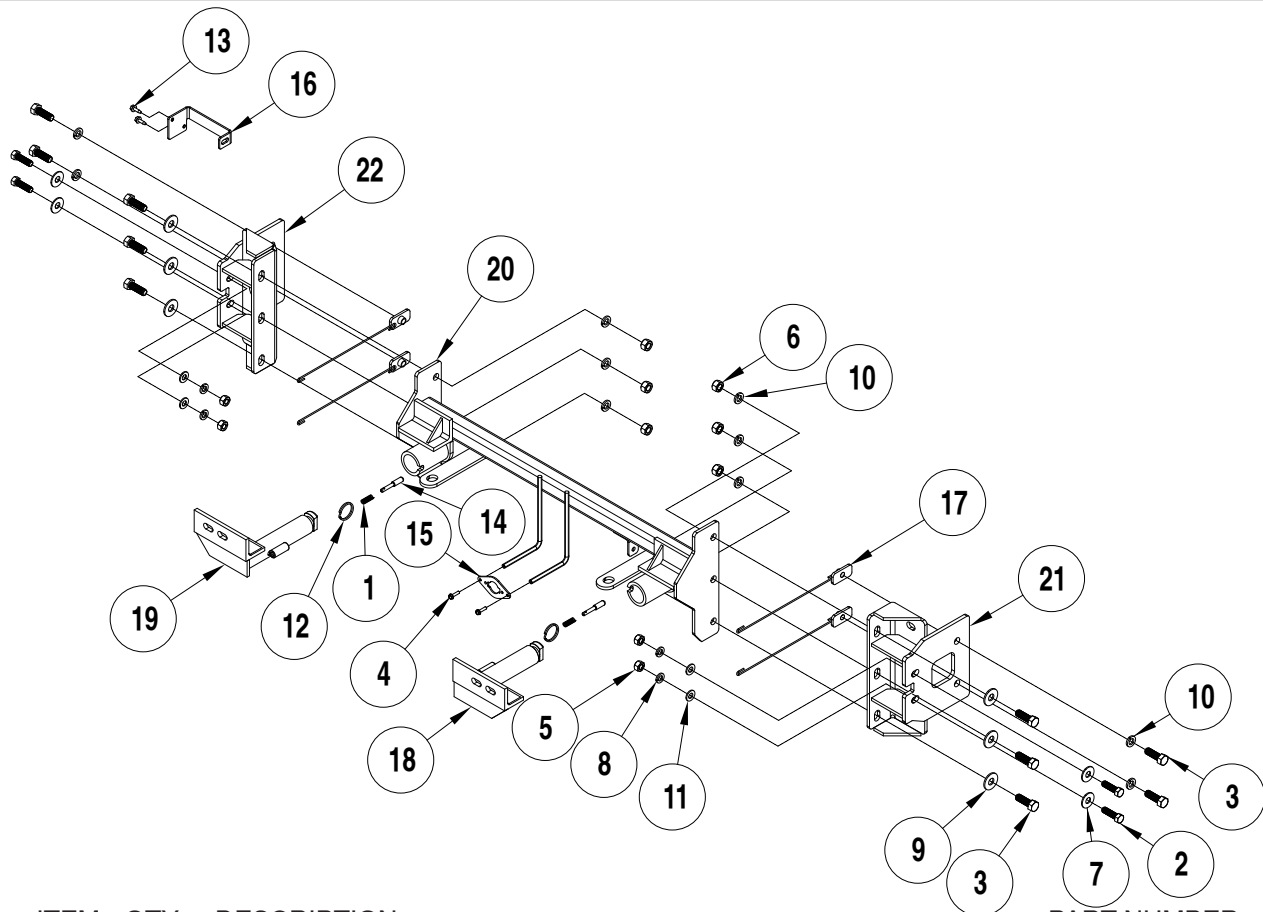

ITEM..	QTY.....	DESCRIPTION.....	PART NUMBER
1.....	2.....	SPRING.....	200146-00
2.....	4.....	7/16" X 1 1/2" BOLT	350074-00
3.....	10.....	1/2" x 1 1/2" BOLT	350095-00
4.....	2.....	#10 x 3/4" SELF DRILLING SCREW	350247-35
5.....	4.....	7/16" HEX NUT	350256-00
6.....	6.....	1/2" HEX NUT	350258-00
7.....	4.....	7/16" FLAT WASHER.....	350306-00
8.....	4.....	7/16" LOCK WASHER.....	350307-00
9.....	6.....	1/2" FLAT WASHER.....	350308-00
10.....	10.....	1/2" LOCK WASHER.....	350309-00
11.....	4.....	7/16" SAE WASHER	350345-00
12.....	2.....	RING	350520-00
13.....	2.....	1/4 X 3/4" SELF DRILLING SCREW.....	357250-00
14.....	2.....	LOCK PIN.....	A000008
15.....	1.....	WIRE PLUG PLATE	A003801
16.....	1.....	PAD BRACKET	B004287
17.....	4.....	1" x 2" THREADED BACKING PLATE W/ 10" ROD	C002105
18.....	1.....	DRIVER SIDE ARM	C003637
19.....	1.....	PASSENGER SIDE ARM.....	C003638
20.....	1.....	MAIN RECEIVER.....	C003639
21.....	1.....	DRIVER SIDE MOUNT	C003640
22.....	1.....	PASSENGER SIDE MOUNT.....	C003641



BASEPLATE KIT INSTALLATION INSTRUCTIONS

KIT# 521458-4

08/24
KS

ROADMASTER, Inc. 6110 NE 127th Ave. Vancouver, WA 98682 360-896-0407 fax 360-735-9300 www.roadmasterinc.com

This is one of our crossbar-style series, which allows the visible front portion of the baseplate to be easily removed from the front of the vehicle (Fig.A and Fig.B). This kit consists of a main receiver brace, two side braces, two removable front braces, and a hardware pack.

The main receiver brace mounts to the frame and side braces on each side. The removable front braces install in the main receiver braces.

Before starting the installation, lay out the kit components in order, as they will be used. This will give you a visual idea of how the components work, and will also confirm that everything is present and accounted for.



IMPORTANT: All baseplates **must** be assembled with all the bolts left loose for final adjustment and positioning (before tightening) unless otherwise instructed. All bolts **must** be torqued for proper strength. If more than one bolt is used per fastening point, the diagram may only show one. Use flat washers over all slotted holes and lock washers on all fasteners.

WARNING

Failure to heed these warnings or follow the installation instructions may result in a voided warranty, loss of towed vehicle, personal injury or death.

- Do not weld or modify this baseplate or its components. Welding or modification will void the warranty.
- Do not use this document as a basis to design/fabricate a baseplate, as it may not show all parts or structural components.
- We strongly recommend professional installation.
- If the towed vehicle has been in an accident, it must be properly repaired before attaching the baseplate. Do not install the baseplate if any structural frame damage is found.
- The installer must use all bolts and parts supplied. If running changes were made by the vehicle manufacturer after this kit was designed, some bolts or other fasteners may no longer be the correct size. It is the installer's responsibility to verify this kit is securely fastened to the vehicle.
- Use Loctite® Red on all bolts used to secure this baseplate. Torque all bolts to the specifications found at the end of these instructions. Do not over-torque the bolts or failure may occur.
- The installer must inspect the baseplate to ensure adequate clearance, particularly around hoses, air conditioner lines, radiators, etc. or non-warranty failure may result.
- Roadmaster manufactures many styles of baseplates. If your baseplate has removable arms, they must be removed before driving the vehicle, unless the arms can be pinned or padlocked in place. If not secured, the arms could vibrate out.
- Some motorhome chassis have such a tight turning radius that you can damage your motorhome, towed vehicle, tow bar or baseplate while turning sharply. Before getting on the road, test your turning radius in an empty parking lot. Turning too sharply could result in non-warranty damage to your towing system, motorhome and/or towed vehicle.
- Do not back up with the towed vehicle attached or non-warranty damage will occur to your towing system or vehicles.
- The safety cables must connect the towing vehicle to the towed vehicle frame to frame, with the cables crossed, with enough slack for sharp turns. See cable instructions for proper routing. Failure to do so will result in non-warranty damage and/or the loss of the towed vehicle.
- This kit is designed for use with ROADMASTER tow bars and ROADMASTER adapters only. Using this kit with other brands, without an approved ROADMASTER adapter, may result in non-warranty damage or injury.
- Receiver extensions and out-of-level towing situations of 3 inches or more. This can cause the system to swing much higher and lower, causing excessive strain on the tow bar, baseplate and frame. That can cause the towing system to fail, causing property damage, personal injury or even death. If you must use a receiver extension or drop hitch to tow, it will reduce your receiver's weight capacity by 1/3 to avoid damaging your system. Never use more than one extension and/or drop hitch, as this will void your warranty.
- Every 3,000 miles, the owner must inspect all mounting points for cracks or fatigue, and check the fasteners for proper torque, according to the bolt torque requirements chart on the last page of these instructions.
- The owner must follow the vehicle manufacturer's instructions to prepare the vehicle for towing. Failure to do so may cause severe damage to the vehicle.
- This baseplate is only warranted for the original installation. Installing a used baseplate on another vehicle is not recommended and will void the warranty.



BASEPLATE KIT INSTALLATION INSTRUCTIONS

KIT# 521458-4

08/24
KS

ROADMASTER, Inc. 6110 NE 127th Ave. Vancouver, WA 98682 360-896-0407 fax 360-735-9300 www.roadmasterinc.com

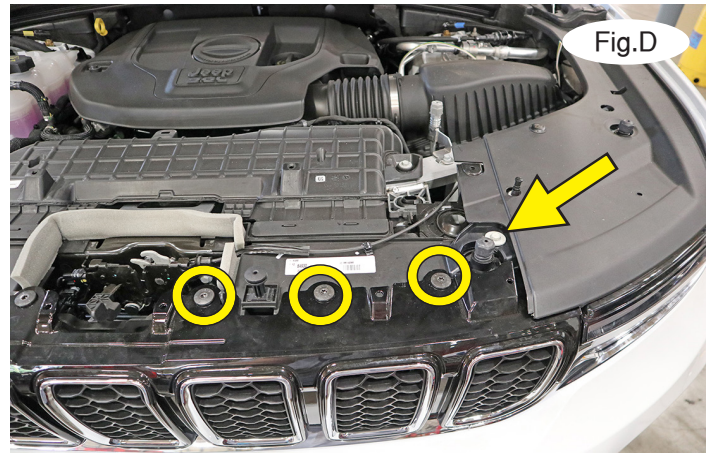

Important: Please use all supplied hardware and read through these instructions carefully before beginning this installation. The majority of questions you may have can be answered within the text, and proper installation will ensure safe and secure travel.

1. On each side, remove six plastic fasteners attaching the radiator cover to the core support (Fig.C). Pull straight up to remove the center section and set it aside for now.
2. On each side, remove one 10mm bolt (Fig.D – arrow) and three T40 torx bolts (Fig.D – circles) attaching the top of the fascia to the core support.

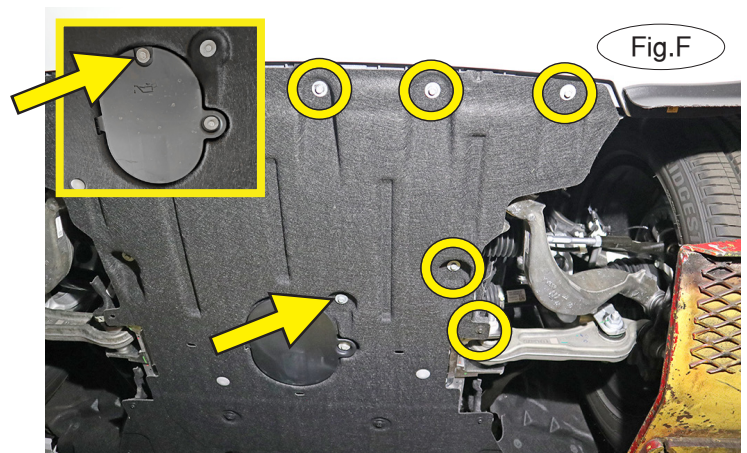

3. **For Trailhawk Models only:** Remove six 10mm bolts attaching the fascia to the frame (Fig.E). **For all other models:** On each side, remove four 10mm bolts and one 8mm screw attaching the splash shield to the frame (Fig.F – circles). *Note:* There is one extra 10mm bolt on the driver's side (Fig.F – arrow). Let the splash shield hang down for now. *Note:* Due to manufacturing variances, there may be an additional 13mm bolt that needs to be removed (Fig.F – inset), or two plastic fasteners.

4. On each side, remove six 8mm screws and two 10mm plastic nuts attaching the fender liner to the sub-frame (Fig.G and Fig.G – inset).

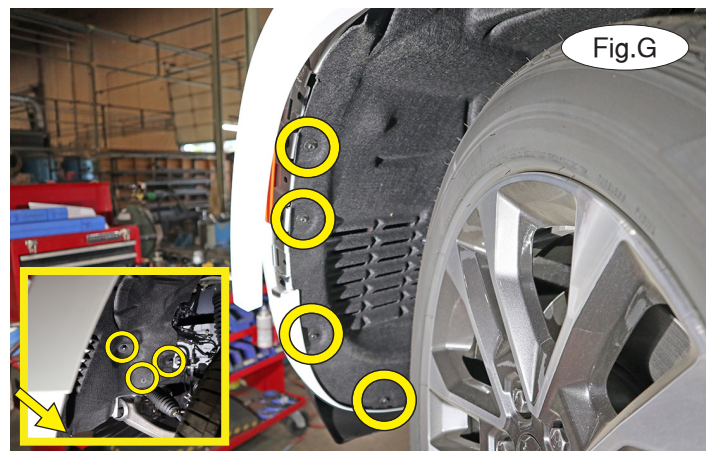

All illustrations and specifications contained herein are based on the latest information available at the time of publication approval. ROADMASTER, INC. reserves the right to make changes at any time without notice in material, specification and models or to discontinue models.



BASEPLATE KIT INSTALLATION INSTRUCTIONS

KIT# 521458-4

08/24
KS

ROADMASTER, Inc. 6110 NE 127th Ave. Vancouver, WA 98682 360-896-0407 fax 360-735-9300 www.roadmasterinc.com



5. On each side, peel back the fender liner and unplug any wiring harnesses in the indicated area (Fig.H). *Note:* If the vehicle has a front camera washer, you will need to cap and secure that line as well.

6. On each side, pull out on the fender trim piece and release the arrowhead clips (Fig.I). Release the clips until you reach the rear arch and then use a soft rag to prop it away from the vehicle. This allows you access to one 10mm bolt attaching the corner of the fascia to the fender. Remove that bolt (Fig.J).

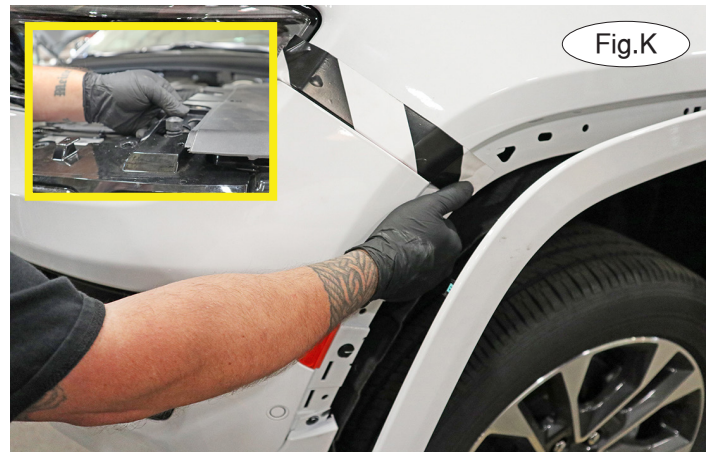

7. With the assistance of a second person, simultaneously pull out on the seam (Fig.K) and pull up on the top of the fascia to clear the hood bump stop (Fig.K – inset). Remove the fascia and set it aside for now.

8. On each side, remove two 16mm bolts attaching the tow hook to the bumper core (Fig.L).

9. On each side, remove two 16mm bolts and one 10mm nut attaching the bumper core to the frame (Fig.M). Pull out to remove the bumper core. It will not be replaced. Save one 10mm nut for replacement in a future step.

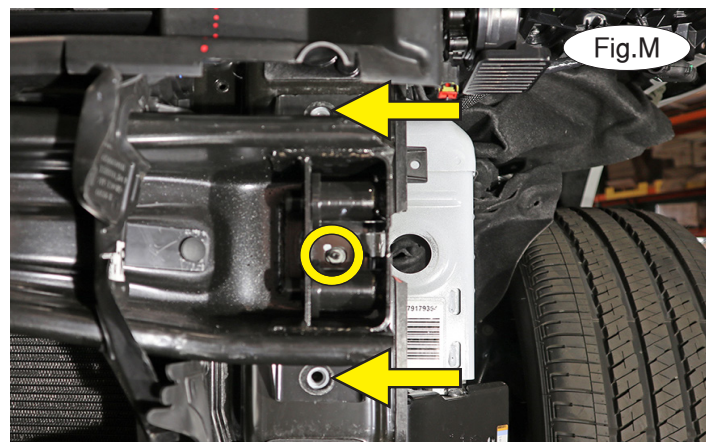
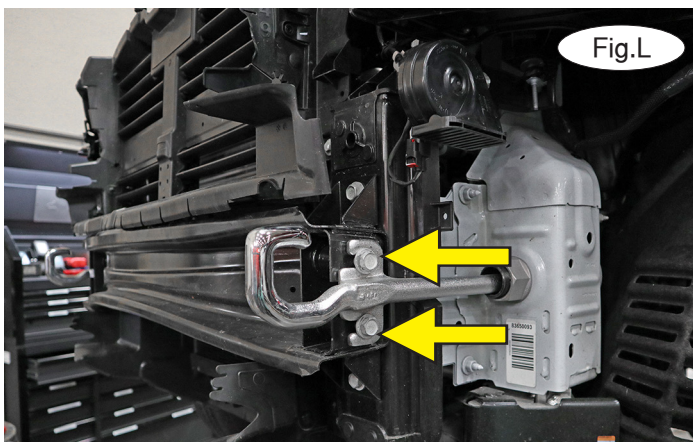



BASEPLATE KIT INSTALLATION INSTRUCTIONS

KIT# 521458-4

08/24
KS

ROADMASTER, Inc. 6110 NE 127th Ave. Vancouver, WA 98682 360-896-0407 fax 360-735-9300 www.roadmasterinc.com

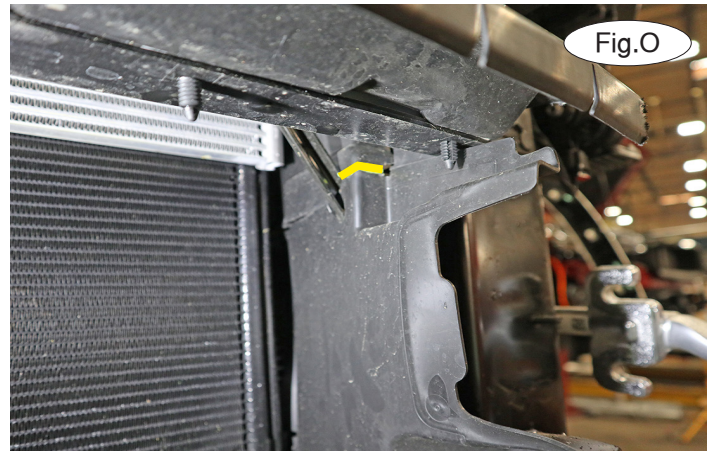
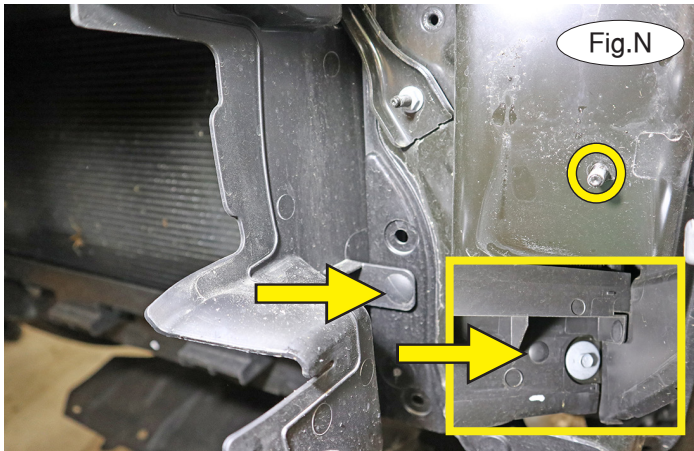

10. On each side, trim off the bumper core mounting stud (Fig.N – circle) using a cut-off wheel or a die grinder. Then, remove two Christmas tree fasteners attaching the lower air dam to the bumper core mounts (Fig.N and Fig.N – inset, arrows). Then, cut the air dam at the spot indicated (Fig.O) and remove it. It will not be replaced.

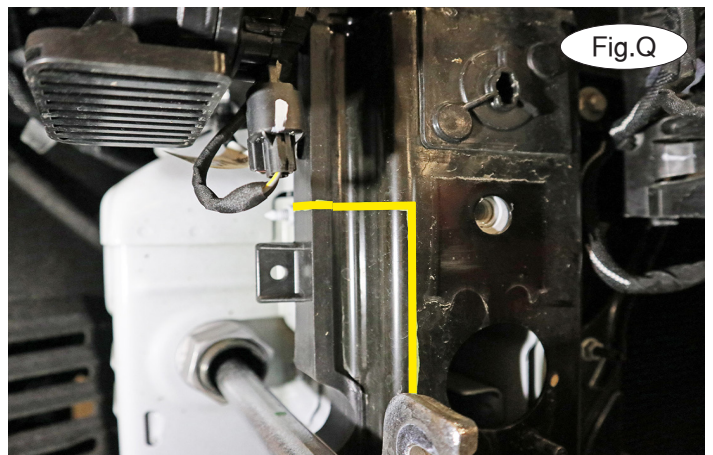
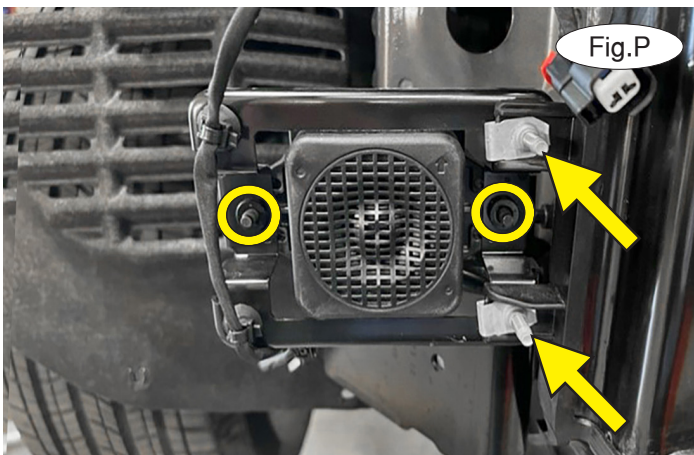

11. **If your vehicle does not have a pedestrian alert device (PAD):** Proceed to the next step. **If your vehicle has a PAD:** Remove two T35 screws attaching the PAD to its mount (Fig.P – circles). Disconnect the plug and its harness and remove two 10mm bolts attaching the factory PAD mount to the core support (Fig.P – arrows). It will not be replaced.

12. On each side, trim the side of the bumper core mount flush with the frame using a cut-off wheel. Follow the yellow lines in Figures Q and R as a reference for trimming (passenger side shown). Retain the 10mm bolt (Fig.R – arrow).

13. On the passenger side only, release the plastic fastener attaching the ambient temperature sensor to the upper air dam (Fig.S). Feed it back through its hole and remount it as shown (Fig.S – inset).

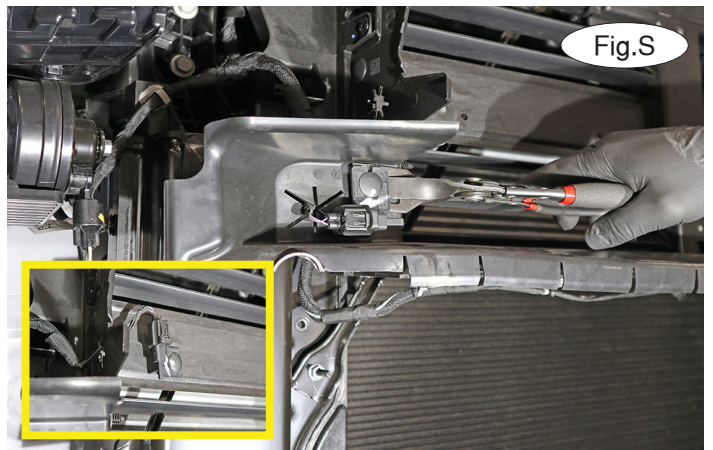
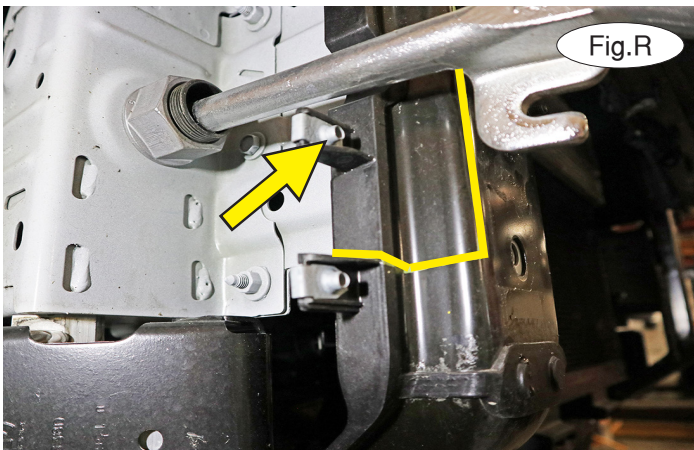



BASEPLATE KIT INSTALLATION INSTRUCTIONS

KIT# 521458-4

08/24
KS

ROADMASTER, Inc. 6110 NE 127th Ave. Vancouver, WA 98682 360-896-0407 fax 360-735-9300 www.roadmasterinc.com

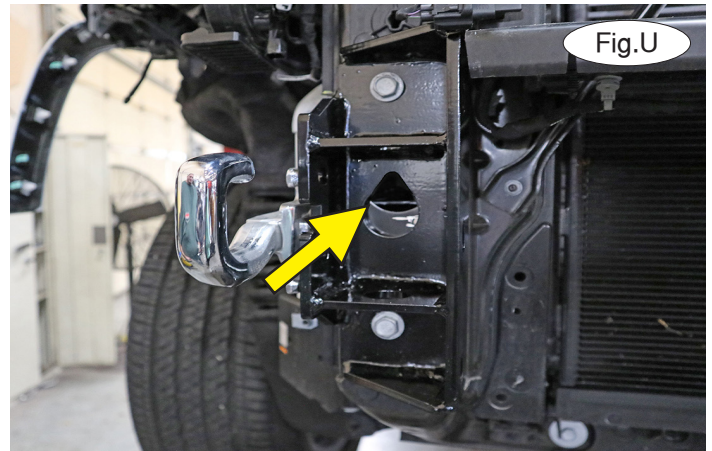
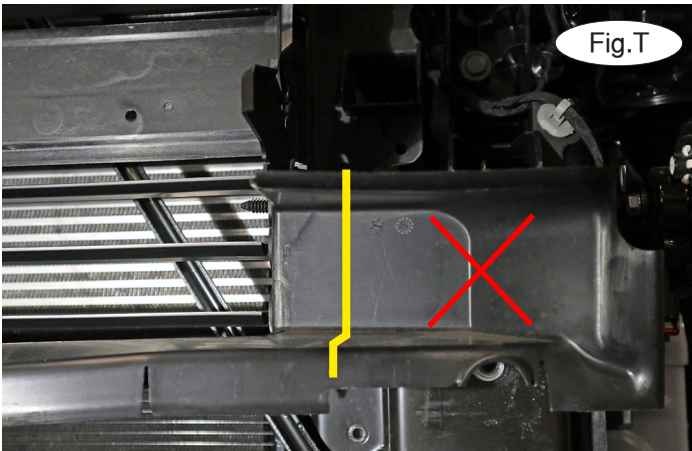

14. On each side, trim the end of the upper air dam at the indicated points (Fig.T) and discard the portion with a red X.

15. Using the drawing on page 1 as a reference, locate the passenger side brace. *Note: The narrow end of the teardrop-shaped opening should point upward (Figure U — arrow).* Place the brace over the bumper core mounts, and use the bolts you removed in step 9 to temporarily secure it (Fig.U). Then, using the holes in the brace as templates, use a 17/32" bit to drill through the side of the frame (Fig.V). *Note: It may be helpful to drill a pilot hole due to the hardness of the material.*

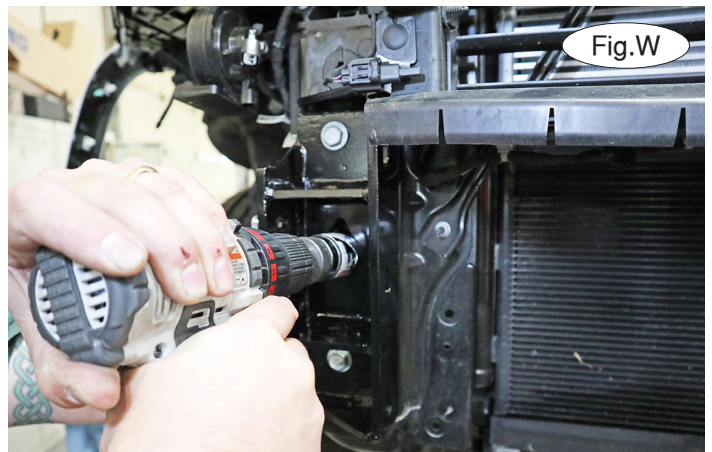
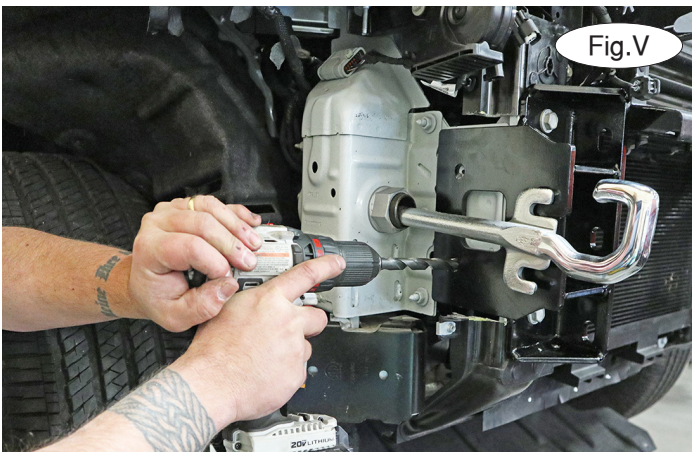

16. On each side, using a 1½" hole saw and the front cut-out on the baseplate as a guide, cut a frame access hole (Fig.W).

17. **If your vehicle does not have a pedestrian alert device (PAD):** Proceed to step 18. **If your vehicle has a PAD:** Refer to the drawing on page 1 to locate the PAD bracket. Use the 10mm bolt you saved from step 11 and the 10mm nut you saved in step 9 to attach the PAD to its bracket and the core support (Fig.X).

17A. **If your vehicle is a 2023/2024 Cherokee, the PAD setup differs:** Find the PAD bracket like in step 17, then mark the back two holes of the bracket on the side of the frame with a marker. Then un-mount the PAD and use two 1/4-14x3/4 hex head drill point screws to mount the bracket to the side of the frame, then use the factory bolt to mount the PAD to the bracket.

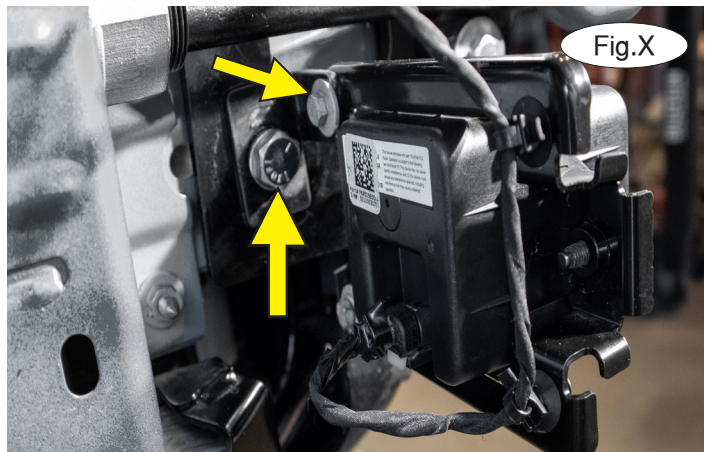



BASEPLATE KIT INSTALLATION INSTRUCTIONS

KIT# 521458-4

08/24
KS

ROADMASTER, Inc. 6110 NE 127th Ave. Vancouver, WA 98682 360-896-0407 fax 360-735-9300 www.roadmasterinc.com

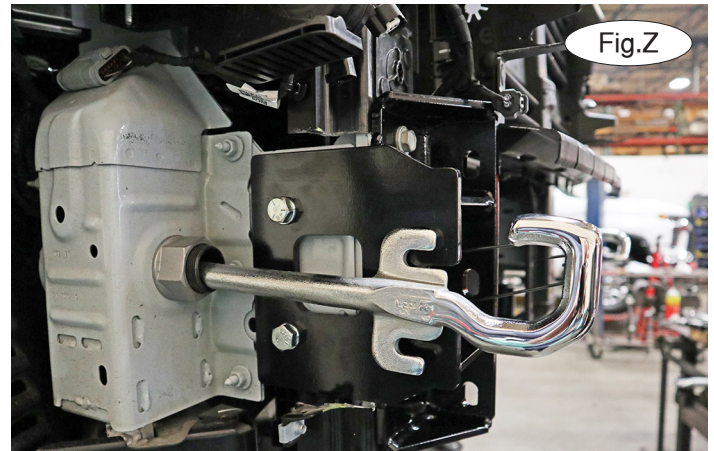

18. Place a $\frac{1}{2}$ " lock washer and Loctite over two $\frac{1}{2}$ " x $1\frac{1}{2}$ " bolts. Locate the $\frac{3}{16}$ " x 1" x 2" threaded backing plates with rods. Bend the rods so the backing plates can be inserted into the frame and over the side mounts (Fig.Y). Then, bolt through the access hole you cut in step 16 and bolt into the backing plate for each hole (Fig.Z). Now, tighten the bolts to the torque specifications.

19. On each side, remove the factory 16mm bolts you temporarily installed in step 15 and place Loctite on them. Reinstall the bolts, and tighten them to the bolt torque specifications found at the end of these instructions.

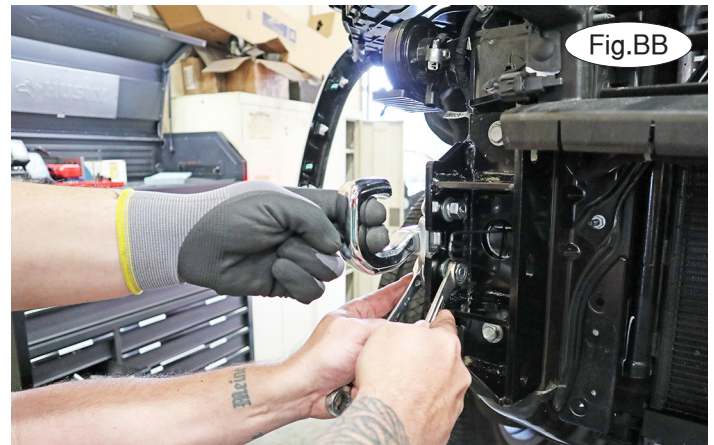
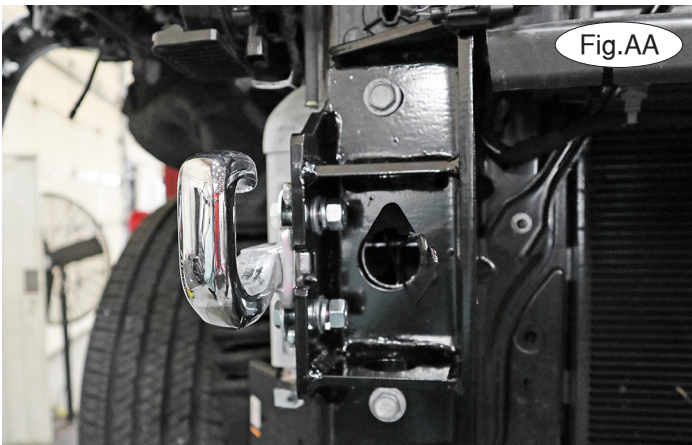

20. Place two $\frac{7}{16}$ " flat washers and Loctite over two $\frac{7}{16}$ " x $2\frac{1}{2}$ " bolts. Loosely install the bolts into the tow hook mounts and finish each bolt with a small $\frac{7}{16}$ " flat washer, $\frac{7}{16}$ " lock washer and $\frac{7}{16}$ " nut (Fig.AA). With the assistance of a second person, apply forward pressure to the tow hook on each side (Fig.BB) and tighten the hardware to the specifications.

21. Place six $\frac{1}{2}$ " flat washers and Loctite over six $\frac{1}{2}$ " x $1\frac{1}{2}$ " bolts. With the assistance of a second person, slide the center brace between the side braces and then bolt the side brace to the center brace on each side using the prepared hardware. When correctly situated, the top edge of the center brace will sit approximately $\frac{1}{8}$ " below the top of the side brace. *Note: Before tightening the hardware, test fit the fascia to ensure adequate clearance. Then, tighten the hardware.*

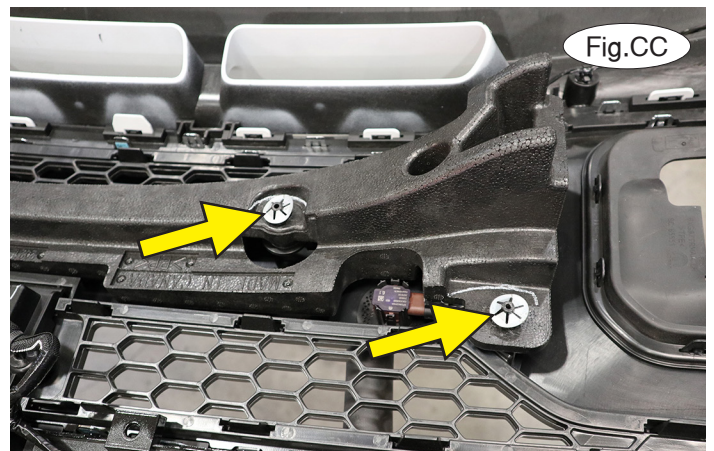

22. On each side, remove two star clips attaching the shock absorption pad to the back of the fascia (Fig.CC). Pull out to remove the pad. It will not be replaced.



BASEPLATE KIT INSTALLATION INSTRUCTIONS

KIT# 521458-4

08/24
KS

ROADMASTER, Inc. 6110 NE 127th Ave. Vancouver, WA 98682 360-896-0407 fax 360-735-9300 www.roadmasterinc.com



23. On each side, disconnect one wiring harness mount from the lower air dam opening (Fig.DD).

24. To allow clearance for the baseplate arms, you will need to either trim the lower grille on each side as shown in Figure EE, or remove the lower grille completely from the back of the fascia. If you choose to remove it, starting on the passenger side, release all of the clips (Fig.FF) and pull out to permanently remove it.



25. Reinstall the fascia by reversing steps 1 through 7.

26. On each side, insert the removable front arm into the front receiver 90 degrees from its final towing position, depressing the spring-loaded pin against the receiver. Twist back 90 degrees until the spring-loaded pin snaps into place in the notch on the receiver, locking the arm into place in its final towing position. **Please note: It is the owner's responsibility to ensure the locking of the pins before towing. Otherwise, failure of the towing system will result.**

27. Install the tow bar to the baseplate according to the manufacturer's instructions.

IMPORTANT!

Safety cables are required by law. When towing, connect safety cables to the safety cable tabs illustrated on the first page and in Figure GG. Make certain there is adequate slack in the cables to allow a full turning radius; otherwise, damage will result. If necessary, longer cables or cable extensions are available.



BASEPLATE KIT INSTALLATION INSTRUCTIONS

KIT# 521458-4

08/24
KS

ROADMASTER, Inc. 6110 NE 127th Ave. Vancouver, WA 98682 360-896-0407 fax 360-735-9300 www.roadmasterinc.com

Three options for attaching the wiring plug to the main receiver brace

For six-wire plugs: use the two supplied 3/4" self-tapping screws to attach the electrical plug directly to the rods on the front of the main receiver brace.

For four-wire round plugs: attach to the plug mounting plate and then use the two supplied 3/4" self-tapping screws to attach the mounting plate to the rods on the front of the main receiver brace.

For four-wire flat plugs: place the plug through the mounting plug plate, and then secure it using the supplied zip tie on the front of the plug (Fig.FF). Use the two supplied 3/4" self-tapping screws to attach the mounting plate to the rods on the front of the main receiver brace.

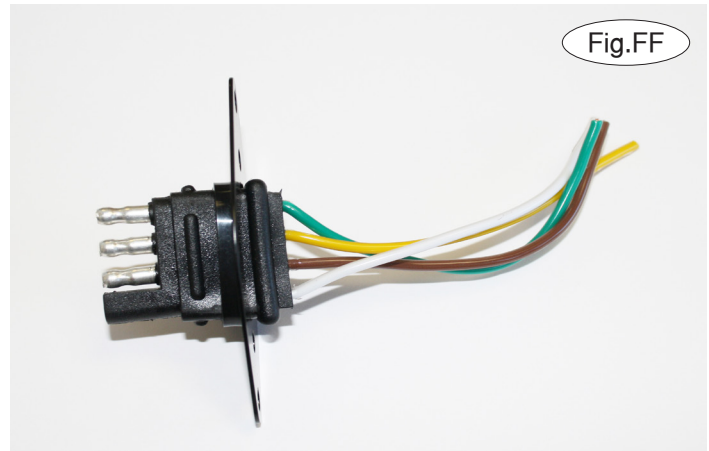

Fig.FF

BOLT TORQUE REQUIREMENTS

Note: The torque values represented below are intended as general guidelines. Torque requirements for specific applications may vary. Roadmaster does not warrant this information to be accurate for all applications and disclaims all liability for any claims or damages which may result from its use.

STANDARD BOLTS

Thread Size	Grade	Torque
5/16-18	5	13 ft./lb.
3/8-16	5	23 ft./lb.
7/16-14	5	37 ft./lb.
1/2-13	5	57 ft./lb.
5/8-11	5	112 ft./lb.

METRIC BOLTS

Thread Size	Grade	Torque
6mm-1.0	8.8	6 ft./lb.
8mm-1.0	8.8	18 ft./lb.
8mm-1.25	8.8	16 ft./lb.
10mm-1.25	8.8	36 ft./lb.
10mm-1.5	8.8	31 ft./lb.

METRIC BOLTS

Thread Size	Grade	Torque
12mm-1.25	8.8	64 ft./lb.
12mm-1.5	8.8	60 ft./lb.
12mm-1.75	8.8	55 ft./lb.
14mm-2.0	8.8	88 ft./lb.

All illustrations and specifications contained herein are based on the latest information available at the time of publication approval. ROADMASTER, INC. reserves the right to make changes at any time without notice in material, specification and models or to discontinue models.