



BASEPLATE KIT INSTALLATION INSTRUCTIONS

KIT# 521877-1

07/25
RS

ROADMASTER, Inc.

6110 NE 127th Ave.

Vancouver, WA 98682

360-896-0407

www.RoadmasterInc.com

Need Help? Call Toll-Free

1-800-669-9690

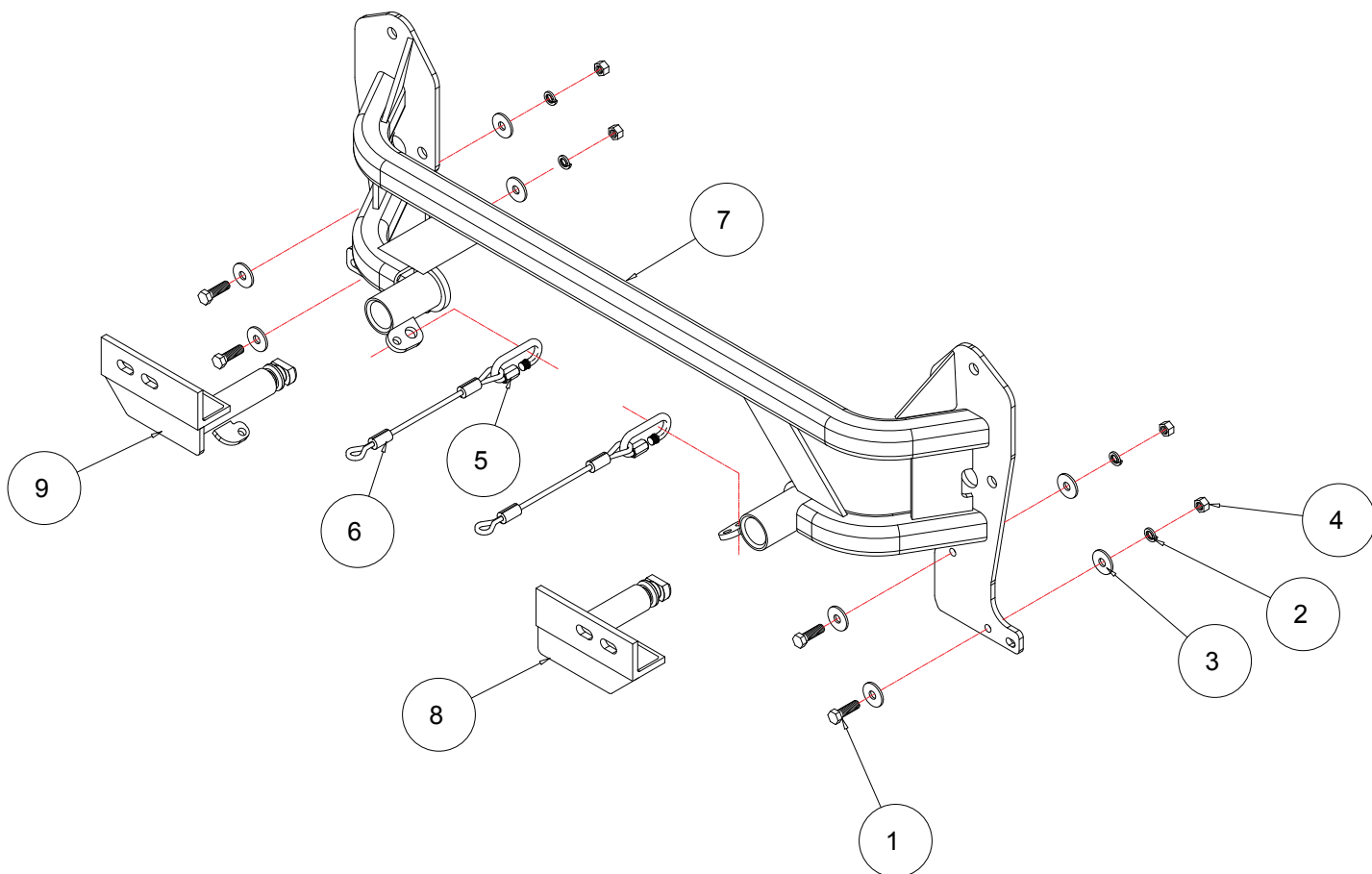

ITEM.....	QTY.....	NAME	PART
1.....	4.....	3/8" x 1 1/4" BOLT.....	350060-00
2.....	4.....	3/8" LOCK WASHER.....	350305-00
3.....	8.....	3/8" FLAT WASHER.....	350304-00
4.....	4.....	3/8" HEX NUT.....	350254-00
5.....	2.....	QUICK LINK.....	200008-00
6.....	2.....	8" SAFETY CABLE.....	500646-08
7.....	1.....	MAIN RECEIVER.....	C-001569
8.....	1.....	DRIVER SIDE ARM.....	C-001570
9.....	1.....	PASSENGER SIDE ARM.....	C-001571
10.....	5.....	ZIP TIE.....	300140-10



BASEPLATE KIT INSTALLATION INSTRUCTIONS

KIT# 521877-1

07/25
RS

ROADMASTER, Inc.

6110 NE 127th Ave.

Vancouver, WA 98682

360-896-0407

www.RoadmasterInc.com

This is one of our crossbar-style baseplates, which allows the visible front portion to be easily removed from the front of the vehicle (Fig.A and Fig.B).

The kit consists of a main receiver brace, two removable front bracket arms and a hardware pack. The main receiver brace mounts to the frame rails; the removable front brackets install in the main receiver brace.

Before starting the installation, lay out the kit components in order, as they will be used. This will give you a visual idea of how the components work, and will also confirm that everything is present and accounted for.



IMPORTANT: All baseplates **must** be assembled with all the bolts left loose for final adjustment and positioning (before tightening) unless otherwise instructed. All bolts **must** be torqued for proper strength. If more than one bolt is used per fastening point, the diagram may only show one. Use flat washers over all slotted holes and lock washers on all fasteners.

WARNING

Failure to heed these warnings or follow the installation instructions may result in a voided warranty, loss of towed vehicle, personal injury or death.

- Do not weld or modify this baseplate or its components. Welding or modification will void the warranty.
- Do not use this document as a basis to design/fabricate a baseplate, as it may not show all parts or structural components.
- We strongly recommend professional installation.
- If the towed vehicle has been in an accident, it must be properly repaired before attaching the baseplate. Do not install the baseplate if any structural frame damage is found.
- The installer must use all bolts and parts supplied. If running changes were made by the vehicle manufacturer after this kit was designed, some bolts or other fasteners may no longer be the correct size. It is the installer's responsibility to verify this kit is securely fastened to the vehicle.
- Use Threadlocker Red on all bolts used to secure this baseplate. Torque all bolts to the specifications found at the end of these instructions. Do not over-torque the bolts or failure may occur.
- The installer must inspect the baseplate to ensure adequate clearance, particularly around hoses, air conditioner lines, radiators, etc. or non-warranty failure may result.
- Roadmaster manufactures many styles of baseplates. If your baseplate has removable arms, they must be removed before driving the vehicle, unless the arms can be pinned or padlocked in place. If not secured, the arms could vibrate out.
- Some motorhome chassis have such a tight turning radius that you can damage your motorhome, towed vehicle, tow bar or baseplate while turning sharply. Before getting on the road, test your turning radius in an empty parking lot. Turning too sharply could result in non-warranty damage to your towing system, motorhome and/or towed vehicle.
- Do not back up with the towed vehicle attached or non-warranty damage will occur to your towing system or vehicles.
- The safety cables must connect the towing vehicle to the towed vehicle frame to frame, with the cables crossed, with enough slack for sharp turns. See cable instructions for proper routing. Failure to do so will result in non-warranty damage and/or the loss of the towed vehicle.
- This kit is designed for use with ROADMASTER tow bars and ROADMASTER adapters only. Using this kit with other brands, without an approved ROADMASTER adapter, may result in non-warranty damage or injury.
- Receiver extensions and out-of-level towing situations of 3" or more can cause the system to swing much higher and lower, causing excessive strain on the tow bar, baseplate and frame. That can cause the towing system to fail, causing property damage, personal injury or even death. If you must use a receiver extension or drop hitch to tow, it will reduce your receiver's towing system's capacity by 1/3 to avoid damaging your system. Never use more than one extension and/or drop hitch, as this will void your warranty.
- Every 3,000 miles, the owner must inspect all mounting points for cracks or fatigue, and check the fasteners for proper torque, according to the bolt torque requirements chart on the last page of these instructions.
- The owner must check and follow the vehicle manufacturer's instructions to prepare the vehicle for towing. Failure to do so may cause severe damage to the vehicle.
- This baseplate is only warranted for the original installation. Installing a used baseplate on another vehicle is not recommended and will void the warranty.



BASEPLATE KIT INSTALLATION INSTRUCTIONS

KIT# 521877-1

07/25
RS

ROADMASTER, Inc.

6110 NE 127th Ave.

Vancouver, WA 98682

360-896-0407

www.RoadmasterInc.com



Fig.C



Fig.D



Fig.E

1. **Important:** please use all supplied bolts and parts and read all instructions carefully before beginning this installation. The majority of questions you may have can be answered within the text, and proper installation will ensure safe and secure travel. Now, begin the installation by removing three plastic fasteners (on each side) attaching the fender liner to the fascia (Fig.C)

2. Pull back on the fender liner, and on both sides, remove the plastic fastener attaching the fender flare to the lower half of the fascia (Fig.D). *Note:* due to manufacturing variances, there may be two plastic fasteners to remove.

3. On both sides, pull the lower corner of the fender flare away, to gain access to the T25 Torx bolt (Fig.E). Then, remove the bolt.

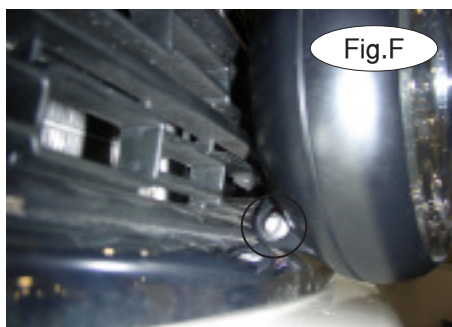

Fig.F



Fig.G

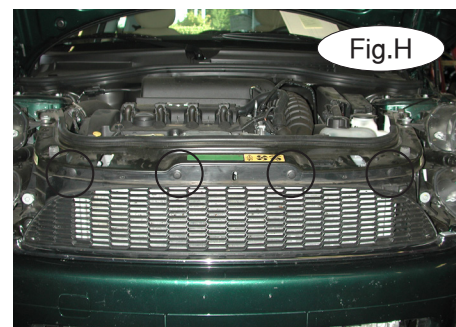

Fig.H

4. If the vehicle is equipped with fog lights, remove two 4mm Allen head screws on each side (Fig.F), and pull forward to release each light from the fog light mount (Fig.G). Now, remove four plastic fasteners attaching the top of the grille to the core support (Fig.H).

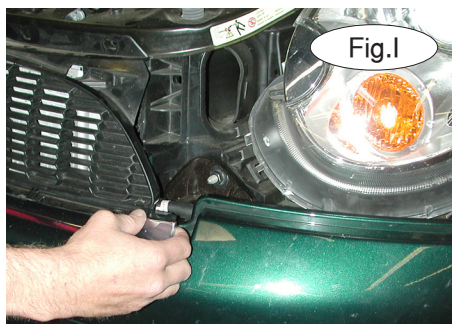

Fig.I



Fig.J

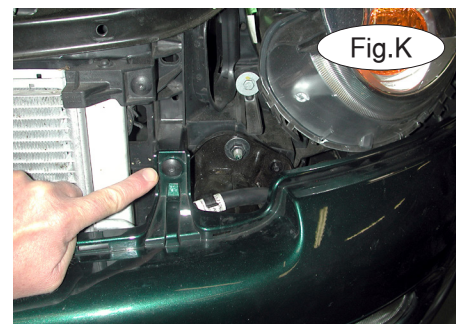

Fig.K

5. Pull forward on the bottom of the grille to remove it (Fig.I).

6. Remove the grille by pushing the four release tabs (Fig.J) toward the center of the car.

7. On each side of the radiator, remove one T25 Torx bolt (Fig.K) attaching the top of the fascia to the core support.



BASEPLATE KIT INSTALLATION INSTRUCTIONS

KIT# 521877-1

07/25
RS

ROADMASTER, Inc.

6110 NE 127th Ave.

Vancouver, WA 98682

360-896-0407

www.RoadmasterInc.com

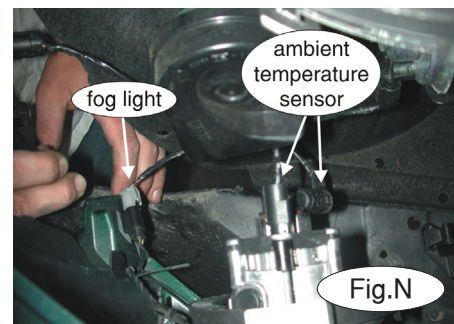
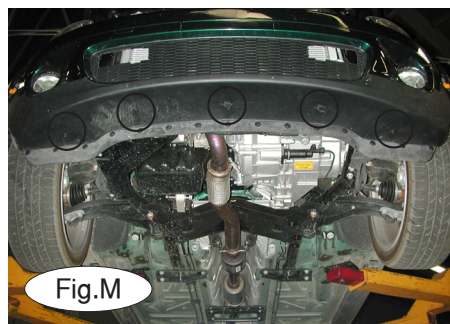

8. Remove the two plastic fasteners (Fig.L) attaching the water line to the top of the fascia.
9. Remove the three plastic fasteners and the two T25 Torx bolts (Fig.M) attaching the bottom of the fascia to the lower radiator support. *Note:* the Torx bolts are on the outside.
10. Pull forward on the fascia to gain access to the fog lights (one on each side) and the ambient temperature sensor (on the passenger side only), and disconnect them (Fig.N). *Note:* do not start the vehicle when the temperature sensor is unplugged because it could cause the check engine light to come on.

Once the fog lights and ambient temperature sensor are disconnected, pull forward on the fascia to disconnect it.

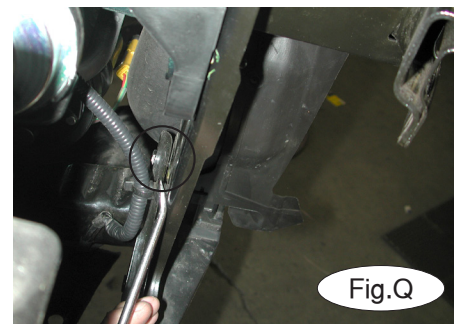
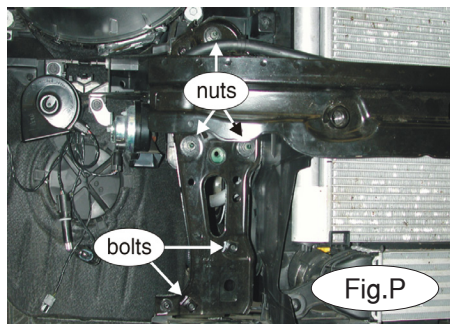
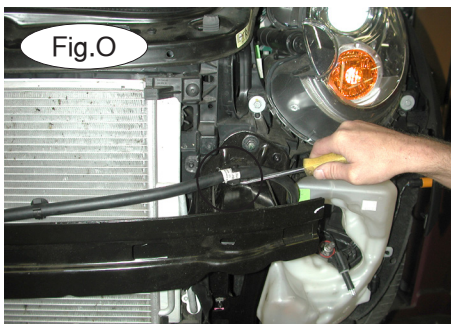

11. Remove the two plastic fasteners (one on each side of the radiator) attaching the water line to the top of the bumper core, if the vehicle is so equipped (Fig.O).
12. On each side, remove three 13mm (head) nuts (at the top of the bumper core) and two 13mm (head) bolts (at the lower rear of the bumper core) attaching the bumper core to the ends of the frame rails (Fig.P).

Note: unscrew the two bolts from the back.

13. Next, on the passenger side only, remove one plastic fastener attaching the wiring harness to the back of the bumper core (Fig.Q).

14. On each side, remove two T20 Torx bolts (one at the top and one at the bottom – Figure R) attaching the bumper core to the core support and then remove it. *Note:* the bumper core will not be re-installed. The main receiver brace will replace it. *Note:* retain the bumper core and attachment hardware for replacement in case the bracket is ever removed.

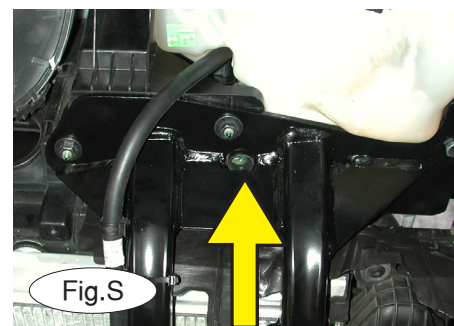
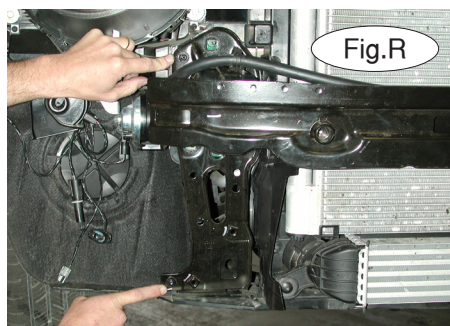

15. Due to manufacturing variances, you may need to remove the plastic ring indicated in Figure S. Test fit the baseplate on each side to determine if the ring must be trimmed flush to allow clearance for the main receiver brace.

All illustrations and specifications contained herein are based on the latest information available at the time of publication approval.
ROADMASTER, INC. reserves the right to make changes at any time without notice in material, specification and models or to discontinue models.



BASEPLATE KIT INSTALLATION INSTRUCTIONS

KIT# 521877-1

07/25
RS

ROADMASTER, Inc.

6110 NE 127th Ave.

Vancouver, WA 98682

360-896-0407

www.RoadmasterInc.com

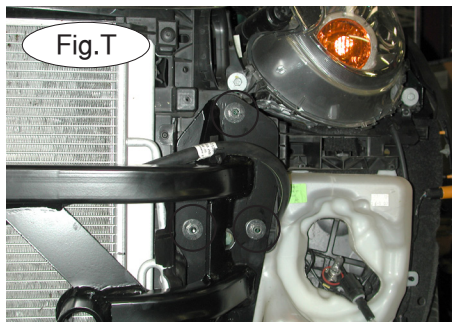

Fig.T

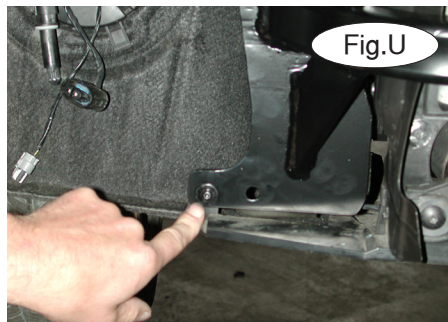

Fig.U

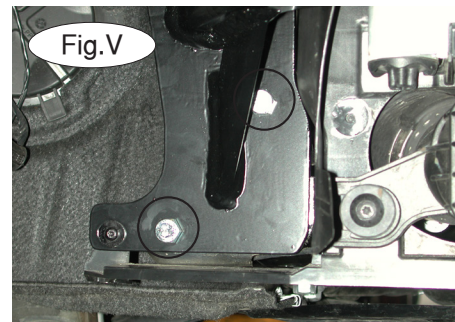

Fig.V

16. Position the main receiver brace over the ends of the frame rails so that the three pre-drilled holes at each end of the main receiver brace align to the holes for the 13mm (head) nuts you removed in step 12 (Fig.T). Reattach the 13mm (head) nuts, through the main receiver brace and into the ends of the frame rails.

17. Attach the main receiver brace to the lower core support – on each side, reattach the lower T20 Torx bolt (Fig.U) you removed in step 14.

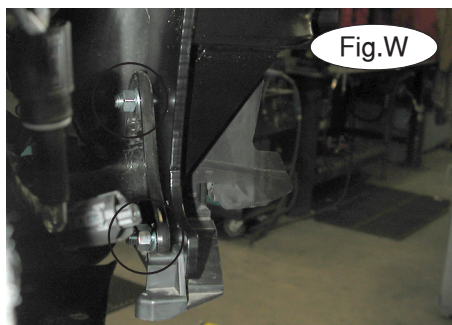

Fig.W

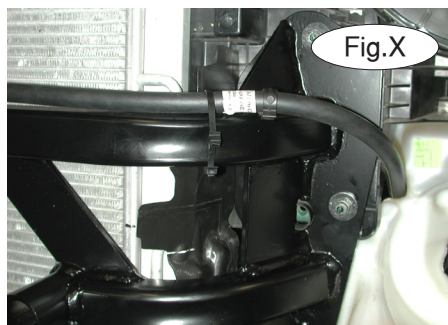

Fig.X



Fig.Y

18. On both sides, using two of the supplied 3/8" x 1 1/4" bolts, flat washers, lock washers and nuts, bolt through the lower half of the main receiver brace and into the ends of the frame rails (Fig.V). *Note:* position the flat washers, lock washers and nuts to the back (Fig.W).

19. Tighten all bolts to the torque specifications found at the end of these instructions. *Note:* the six 13mm (head) nuts are torqued to the 8mm-1.25 torque specification.

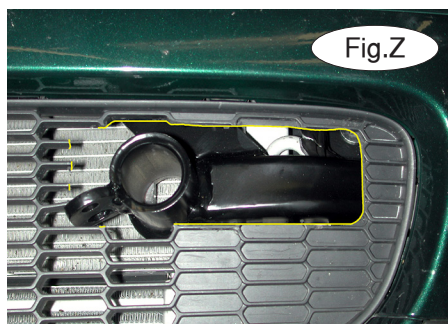

Fig.Z

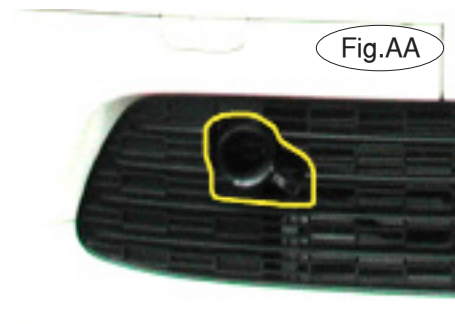

Fig.AA

20. Attach two of the supplied zip ties together. Then, at one side of the main receiver brace, loop them around the water line and the end of the cross bar on the main receiver brace. Tighten the zip ties to secure the water line to the main receiver brace (Fig.X). Repeat for the other side.

21. In order to accommodate the removable front brackets, a section from both ends of the fascia must be trimmed. On the passenger side, this section contains the mounting point for the ambient temperature sensor. Before trimming the fascia, first drill a 1/4" hole in the plastic flange, and attach the ambient temperature sensor as shown in Figure Y.

22. Hold the fascia in place over the main receiver brace and mark the area to be trimmed, using the yellow marker lines in Figure Z as a reference. **For 2009 to 2010 models:** use the yellow marker lines in Figure AA as a guide for trimming. Trim an equal amount from each side of the fascia.

23. Reinstall the fascia, reversing steps 1 through 10.



BASEPLATE KIT INSTALLATION INSTRUCTIONS

KIT# 521877-1

07/25
RS

ROADMASTER, Inc.

6110 NE 127th Ave.

Vancouver, WA 98682

360-896-0407

www.RoadmasterInc.com

- 24. Insert the removable front brackets into the front receiver braces, and rotate 90 degrees to lock.
- 25. Install the tow bar to the mounting bracket according to the manufacturer's instructions.
- 26. Attach the 8" safety cables with the cable connectors (Q-Links) to the front of the receiver braces (Fig.BB).
- 27. Attach the ends of the safety cables to the tow vehicle's safety cables and tow bar.



BOLT TORQUE REQUIREMENTS

Note: The torque values represented below are intended as general guidelines. Torque requirements for specific applications may vary. Roadmaster does not warrant this information to be accurate for all applications and disclaims all liability for any claims or damages which may result from its use.

STANDARD BOLTS

Thread Size	Grade	Torque
5/16-18	5	13 ft./lb.
3/8-16	5	23 ft./lb.
7/16-14	5	37 ft./lb.
1/2-13	5	57 ft./lb.
5/8-11	5	112 ft./lb.

METRIC BOLTS

Thread Size	Grade	Torque
6mm-1.0	8.8	6 ft./lb.
8mm-1.0	8.8	18 ft./lb.
8mm-1.25	8.8	16 ft./lb.
10mm-1.25	8.8	36 ft./lb.
10mm-1.5	8.8	31 ft./lb.

METRIC BOLTS

Thread Size	Grade	Torque
12mm-1.25	8.8	64 ft./lb.
12mm-1.5	8.8	60 ft./lb.
12mm-1.75	8.8	55 ft./lb.
14mm-2.0	8.8	88 ft./lb.

All illustrations and specifications contained herein are based on the latest information available at the time of publication approval. ROADMASTER, INC. reserves the right to make changes at any time without notice in material, specification and models or to discontinue models.