



BASEPLATE KIT INSTALLATION INSTRUCTIONS

KIT# 521880-1

10/25
RS

ROADMASTER, Inc.

6110 NE 127th Ave.

Vancouver, WA 98682

360-896-0407

www.RoadmasterInc.com

What You'll Need

A second person to help
Flathead screwdriver
T15 Driver
Needle nose pliers

Sockets and Wrenches
Ratchets
Permanent marker

Tape measure
Torque wrench
Threadlocker Red

Need Help? Call Toll-Free

1-800-669-9690

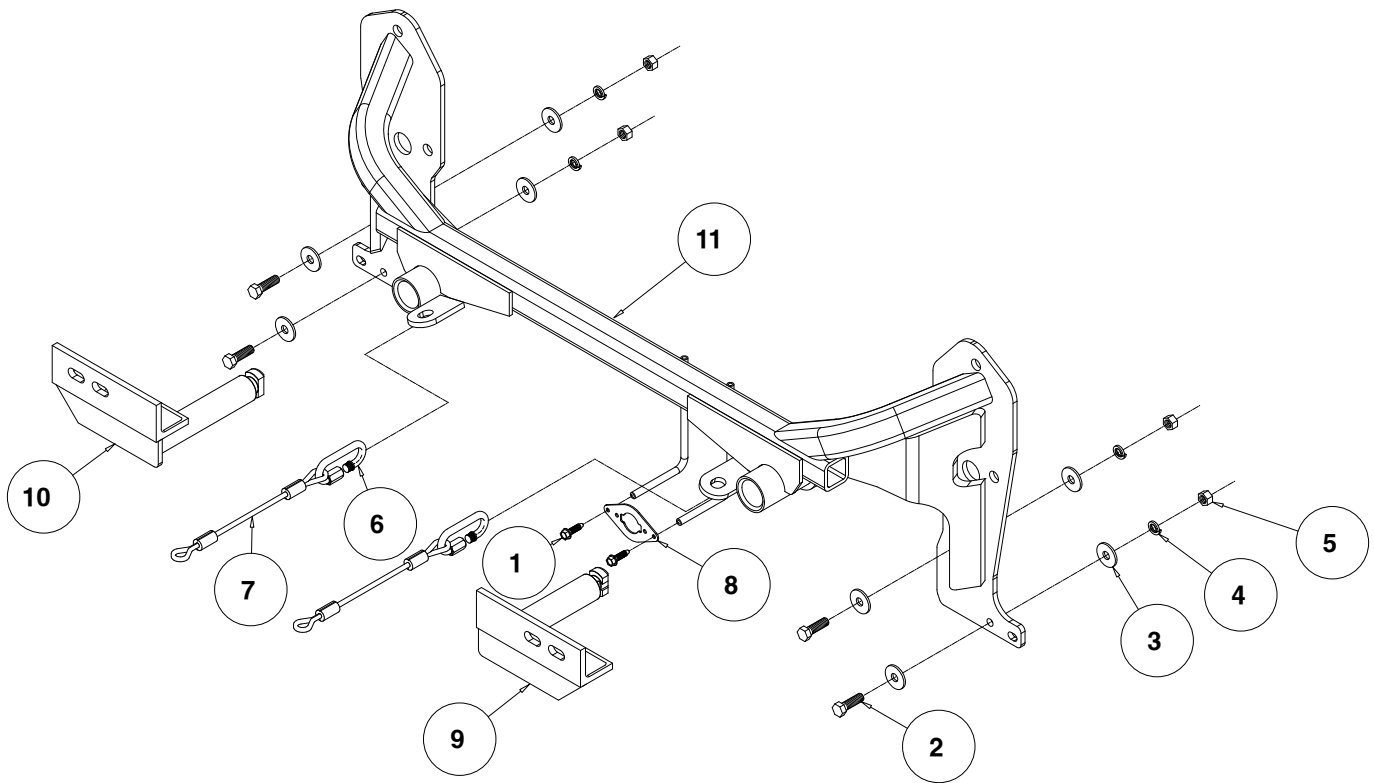

ITEM.....	QTY	NAME	MATERIAL
1.....	2.....	#10 x 3/4" SELF TAPPING SCREW.....	350247-35
2.....	4.....	3/8" x 1 1/4" BOLT.....	350056-00
3.....	8.....	3/8" FLAT WASHER	350304-00
4.....	4.....	3/8" LOCK WASHER	350305-00
5.....	4.....	3/8" HEX NUT	350254-00
6.....	2.....	QUICK LINK	200008-00
7.....	2.....	8" SAFETY CABLE.....	650646-08
8.....	1.....	WIRE PLUG MOUNTING PLATE.....	A-003801
9.....	1.....	DRIVER SIDE ARM.....	C-002316
10.....	1.....	PASSENGER SIDE ARM	C-002317
11.....	1.....	MAIN RECEIVER	C-002318
12.....	5.....	ZIP TIE.....	300140-10

All illustrations and specifications contained herein are based on the latest information available at the time of publication approval.
ROADMASTER, INC. reserves the right to make changes at any time without notice in material, specification and models or to discontinue models.



BASEPLATE KIT INSTALLATION INSTRUCTIONS

KIT# 521880-1

10/25
RS

ROADMASTER, Inc.

6110 NE 127th Ave.

Vancouver, WA 98682

360-896-0407

www.RoadmasterInc.com

IMPORTANT: All baseplates **must** be assembled with all the bolts left loose for final adjustment and positioning (before tightening) unless otherwise instructed. All bolts **must** be torqued for proper strength. If more than one bolt is used per fastening point, the diagram may only show one. Use flat washers over all slotted holes and lock washers on all fasteners.

WARNING

Failure to heed these warnings or follow the installation instructions may result in a voided warranty, loss of towed vehicle, personal injury or death.

- Do not weld or modify this baseplate or its components. Welding or modification will void the warranty.
- Do not use this document as a basis to design/fabricate a baseplate, as it may not show all parts or structural components.
- We strongly recommend professional installation.
- If the towed vehicle has been in an accident, it must be properly repaired before attaching the baseplate. **Do not install the baseplate if any structural frame damage is found.**
- The installer must use all bolts and parts supplied. If running changes were made by the vehicle manufacturer after this kit was designed, some bolts or other fasteners may no longer be the correct size. **It is the installer's responsibility to verify this kit is securely fastened to the vehicle.**
- **Use Loctite® Red on all bolts used to secure this baseplate.** Torque all bolts to the specifications found at the end of these instructions. Do not over-torque the bolts or failure may occur.
- The installer must inspect the baseplate to ensure adequate clearance, particularly around hoses, air conditioner lines, radiators, etc. or non-warranty failure may result.
- Roadmaster manufactures many styles of baseplates. **If your baseplate has removable arms, they must be removed before driving the vehicle, unless the arms can be pinned or padlocked in place.** If not secured, the arms could vibrate out.
- Some motorhome chassis have such a tight turning radius that you can damage your motorhome, towed vehicle, tow bar or baseplate while turning sharply. **Before getting on the road, test your turning radius in an empty parking lot.** Turning too sharply could

result in non-warranty damage to your towing system, motorhome and/or towed vehicle.

- Do not back up with the towed vehicle attached or non-warranty damage will occur to your towing system or vehicles.
- The safety cables must connect the towing vehicle to the towed vehicle frame to frame, with the cables crossed, with enough slack for sharp turns. See cable instructions for proper routing. Failure to do so will result in non-warranty damage and/or the loss of the towed vehicle.
- This kit is designed for use with ROADMASTER tow bars and ROADMASTER adapters only. **Using this kit with other brands, without an approved ROADMASTER adapter, may result in non-warranty damage or injury.**
- Receiver extensions and out-of-level towing situations of 3 inches or more. This can cause the system to swing much higher and lower, causing excessive strain on the tow bar, baseplate and frame. That can cause the towing system to fail, causing property damage, personal injury or even death. **If you must use a receiver extension or drop hitch to tow, it will reduce your receiver's weight capacity by 1/3 to avoid damaging your system. Never use more than one extension and/or drop hitch, as this will void your warranty.**
- Every 3,000 miles, the owner must inspect all mounting points for cracks or fatigue, and check the fasteners for proper torque, according to the bolt torque requirements chart on the last page of these instructions.
- The owner must follow the vehicle manufacturer's instructions to prepare the vehicle for towing. Failure to do so may cause severe damage to the vehicle.
- This baseplate is only warranted for the original installation. Installing a used baseplate on another vehicle is not recommended and will void the warranty.

About this kit:

This is one of our crossbar-style series, which allows the visible front portion of the baseplate to be easily removed from the front of the vehicle (Fig.A and Fig.B).

This kit consists of a main receiver brace, two rear support braces, two removable front braces, and a hardware pack.

The main receiver brace mounts to the frame and side braces on each side. The removable front braces install in the main receiver braces.

Before starting the installation, lay out the kit components in order, as they will be used. This will give you a visual idea of how the components work, and will also confirm that everything is present and accounted for.





BASEPLATE KIT INSTALLATION INSTRUCTIONS

KIT# 521880-1

10/25
RS

ROADMASTER, Inc.

6110 NE 127th Ave.

Vancouver, WA 98682

360-896-0407

www.RoadmasterInc.com

Important: Please use all supplied hardware and read through these instructions carefully before beginning this installation. The majority of questions you may have can be answered within the text, and proper installation will ensure safe and secure travel.



1. **Important:** please use all supplied bolts and parts and read all instructions carefully before beginning this installation. The majority of questions you may have can be answered within the text, and proper installation will ensure safe and secure travel. Now, begin the installation by removing three plastic fasteners (on each side) attaching the fender liner to the fascia (Fig.C).

2. Pull back on the fender liner and, on both sides, remove the plastic fastener attaching the fender flare to the lower half of the fascia (Fig.D). *Note:* due to manufacturing variances, there may be two plastic fasteners to remove.



3. On each side, pull the lower corner of the fender flare away to gain access to the T25 Torx bolt (Fig.E) and then remove it.

4. If the vehicle is equipped with fog lights, remove two 4mm Allen head screws on each side (Fig.F) and pull forward to release each light from the fog light mount (Fig.G)





BASEPLATE KIT INSTALLATION INSTRUCTIONS

KIT# 521880-1

10/25
RS

ROADMASTER, Inc.

6110 NE 127th Ave.

Vancouver, WA 98682

360-896-0407

www.RoadmasterInc.com

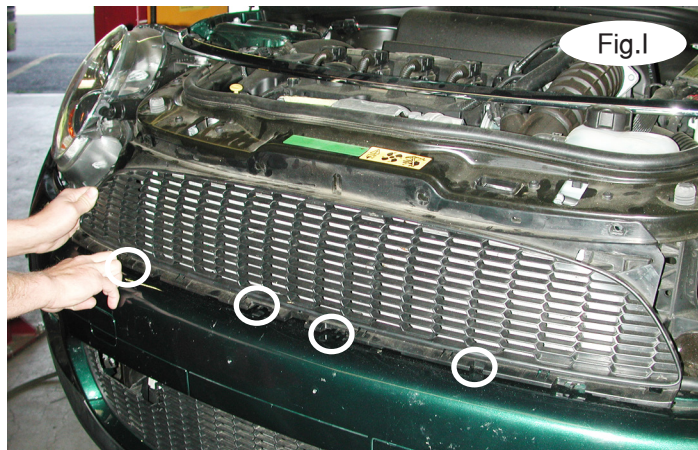
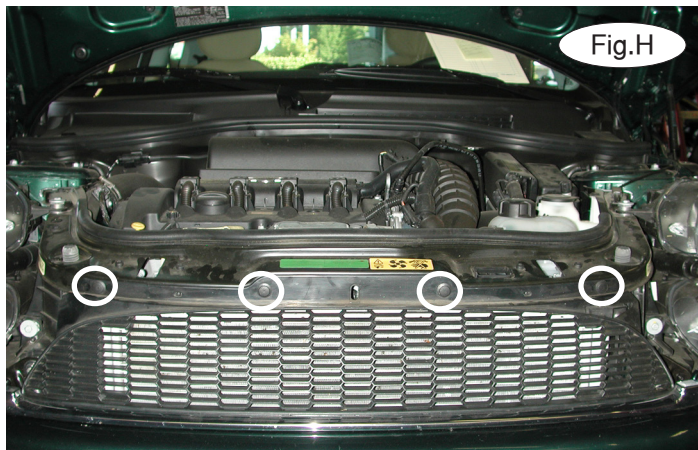

5. Remove four plastic fasteners attaching the top of the grille to the core support (Fig.H).
6. Remove the grille by pushing the four release tabs (Fig.I) toward the center of the car.

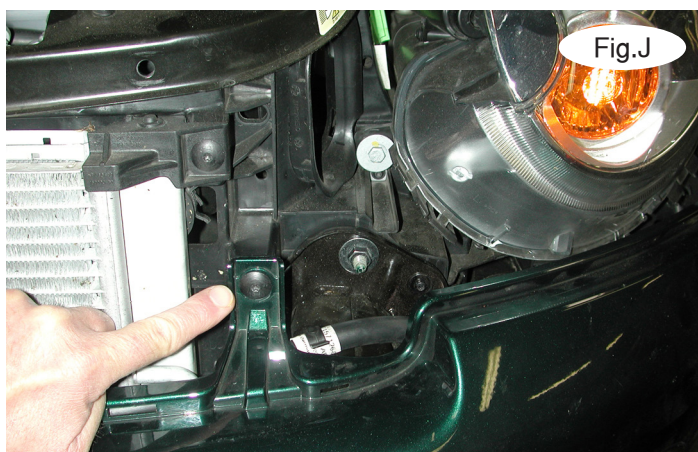

7. On each side of the radiator, remove one T25 Torx bolt (Fig.J) attaching the top of the fascia to the core support.

8. Remove the two plastic fasteners attaching the water line to the top of the fascia (Fig.K). *Note:* due to manufacturing variances, not every vehicle will be equipped with this water line.

9. Remove three plastic fasteners and two T25 Torx bolts (Fig.L) attaching the bottom of the fascia to the lower radiator support. *Note:* the Torx bolts are to the outside of the vehicle.





BASEPLATE KIT INSTALLATION INSTRUCTIONS

KIT# 521880-1

10/25
RS

ROADMASTER, Inc.

6110 NE 127th Ave.

Vancouver, WA 98682

360-896-0407

www.RoadmasterInc.com

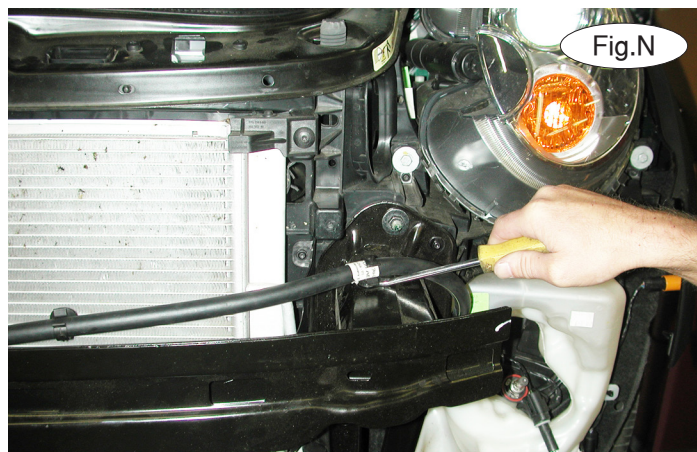
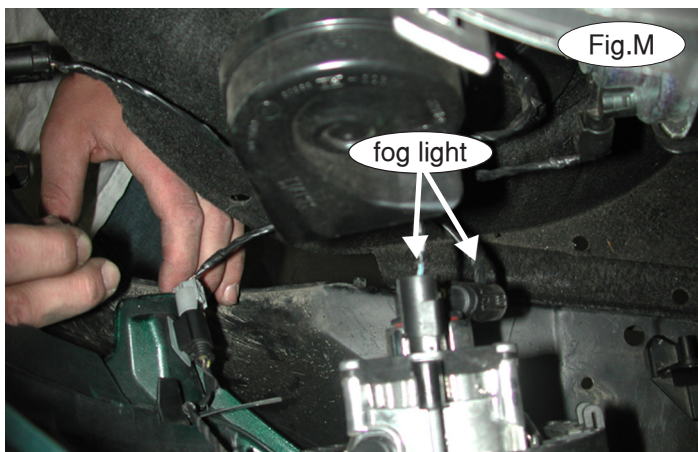

10. Pull forward on the fascia to gain access to the fog lights and disconnect them (Fig.M). Also, locate the ambient temperature sensor (on the passenger side only) and disconnect it. *Note:* do not start the vehicle when the temperature sensor is unplugged because it could cause the 'Check Engine' light to illuminate.

11. On each side of the radiator, remove one plastic fastener attaching the water line to the top of the bumper core (Fig.N). *Note:* due to manufacturing variances, not every vehicle will be equipped with this water line.

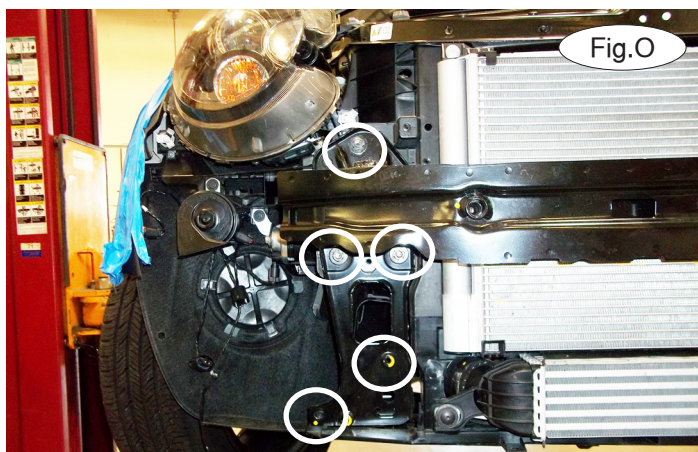

12. On each side, remove three 13mm (head) bolts and two 13mm (head) bolts attaching the bumper core to the end of the frame rail (Fig.O). *Note:* the two bolts will need to be unscrewed from the rear of the bumper core.

13. On the passenger side only, remove one plastic fastener attaching the wiring harness to the back of the bumper core (Fig.P).

14. On each side, remove two T20 Torx bolts attaching the bumper core to the core support (Fig.Q).

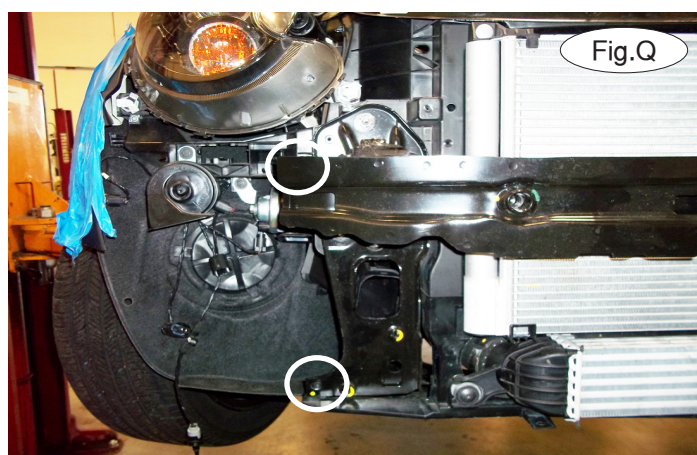



BASEPLATE KIT INSTALLATION INSTRUCTIONS

KIT# 521880-1

10/25
RS

ROADMASTER, Inc.

6110 NE 127th Ave.

Vancouver, WA 98682

360-896-0407

www.RoadmasterInc.com



Fig.R



Fig.S

15. Remove the bumper core (Fig.R). The bumper core will not be re-installed. *Note:* retain the bumper core and attachment hardware for replacement in case the bracket is ever removed.

16. Position the main receiver brace over the ends of the frame rails so that the three pre-existing holes at each end of the brace align with the holes in the bumper core mount. Reinstall the bolts that you removed in step 12. Bolt the main receiver brace to the lower core support using the two lower T20 Torx bolts you removed in step 14 (Fig.S). *Note:* use Loctite® Red on all bolts used for mounting this bracket.

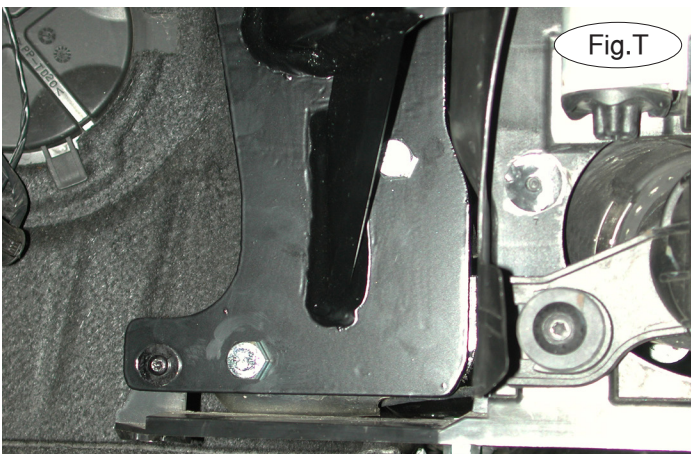

Fig.T



Fig.U

17. On each side, using two of the supplied 3/8" x 1 1/4" bolts, 3/8" flat washers, lock washers and nuts, bolt through the lower half of the main receiver brace and into the ends of the frame rails (Fig.T). *Note:* due to manufacturing variances, these holes may need to be slightly enlarged.

18. Using the two zip ties, remount the ambient temperature sensor to the main receiver brace.

19. Hold the fascia in place over the main receiver brace and trim the fascia using the yellow lines in Figure U as a guide for trimming.

20. Torque the 3/8" bolts to 23 ft./lbs. Torque the 13mm factory hardware to 19 ft./lbs and then torque all remaining bolts to the bolt torque requirements found at the end of these instructions.

21. Reinstall the fascia, reversing steps 1 through 9.

22. Insert the removable front bracket arms into the front receiver braces, and twist each one 90 degrees to lock.

23. Attach the 8" safety cables with the cable connectors (Q-Links) to the front of the receiver braces (Fig.V).

24. Attach the ends of the safety cables to the tow vehicle's safety cables.

25. Install the tow bar to the mounting bracket according to the manufacturer's instructions.



BASEPLATE KIT INSTALLATION INSTRUCTIONS

KIT# 521880-1

10/25
RS

ROADMASTER, Inc.

6110 NE 127th Ave.

Vancouver, WA 98682

360-896-0407

www.RoadmasterInc.com

IMPORTANT!

Safety cables are required by law. When towing, connect safety cables to the safety cable tabs illustrated on the separate insert with the drawing and parts list and in Figure AA. Make certain there is adequate slack in the cables to allow a full turning radius; otherwise, damage will result. If necessary, longer cables or cable extensions are available.

WARNING!

If you do not use Threadlocker Red on all bolts in this kit and torque to the specified values, it could cause failure of the towing system.

Three options for attaching the wiring plug to the main receiver brace:

For six-wire plugs: Use the two supplied 3/4" self-tapping screws to attach the electrical plug directly to the rods on the front of the main receiver brace.

For four-wire round plugs: Attach to the plug mounting plate and then use the two supplied 3/4" self-tapping screws to attach the mounting plate to the rods on the front of the main receiver brace.

For four-wire flat plugs: Place the plug through the mounting plug plate, and then secure it using the supplied zip tie on the front of the plug (Adjacent Figure). Use the two supplied 3/4" self-tapping screws to attach the mounting plate to the rods on the front of the main receiver brace.

Plug may need to be pushed in and down to meet clearance.

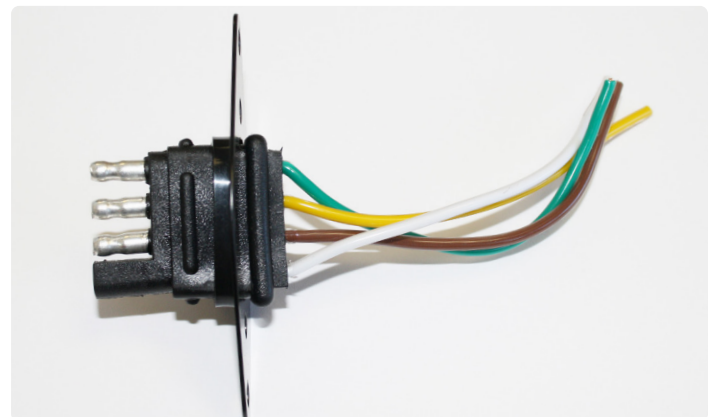
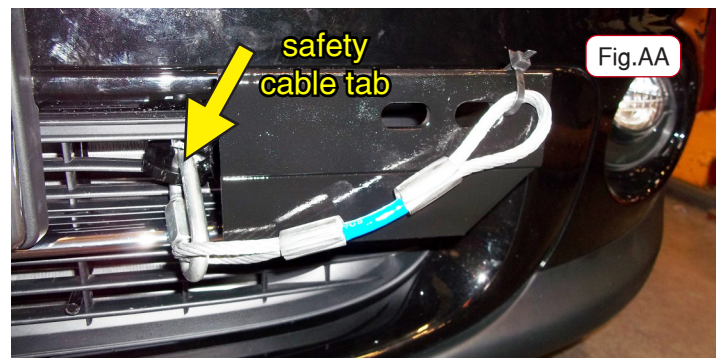

BOLT TORQUE REQUIREMENTS

Note: The torque values represented below are intended as general guidelines. Torque requirements for specific applications may vary. Roadmaster does not warrant this information to be accurate for all applications and disclaims all liability for any claims or damages which may result from its use.

STANDARD BOLTS

Thread Size	Grade	Torque
5/16-18	5	13 ft./lb.
3/8-16	5	23 ft./lb.
7/16-14	5	37 ft./lb.
1/2-13	5	57 ft./lb.
5/8-11	5	112 ft./lb.

METRIC BOLTS

Thread Size	Grade	Torque
6mm-1.0	8.8	6 ft./lb.
8mm-1.0	8.8	18 ft./lb.
8mm-1.25	8.8	16 ft./lb.
10mm-1.25	8.8	36 ft./lb.
10mm-1.5	8.8	31 ft./lb.

METRIC BOLTS

Thread Size	Grade	Torque
12mm-1.25	8.8	64 ft./lb.
12mm-1.5	8.8	60 ft./lb.
12mm-1.75	8.8	55 ft./lb.
14mm-2.0	8.8	88 ft./lb.