



# BASEPLATE KIT INSTALLATION INSTRUCTIONS

**KIT# 521883-5**

05/31/23  
KS

ROADMASTER, Inc. 6110 NE 127th Ave. Vancouver, WA 98682 360-896-0407 fax 360-735-9300 www.roadmasterinc.com

Second person for lifting  
Ratchets  
3/8", 7/16", 9/16", 3/4" sockets  
3/8", 9/16", 3/4" wrenches  
T15 and T25 Torx driver

**What You'll Need**  
8, 10, 13, 16, and  
17mm sockets  
Long flathead screwdriver

Reciprocating saw  
Flat head screwdriver  
Panel tool  
Torque wrench  
Loctite® Red or Blue

**Important**

Note: This baseplate will not accommodate the Guardian rock shield, some models of the Tow Defender, or StowMaster tow bars.

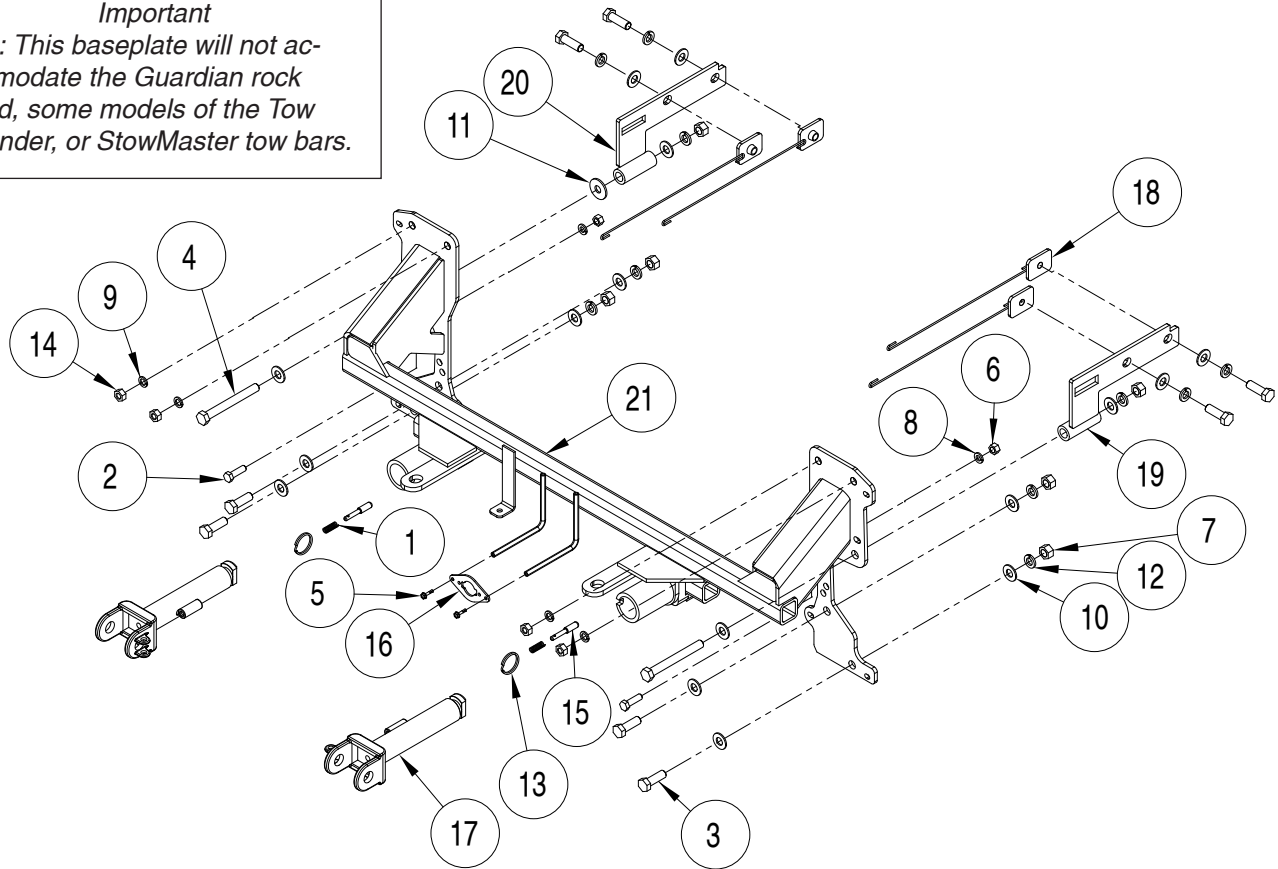

ITEM	QTY	DESCRIPTION	PART NUMBER
1.....	2 .....	SPRING .....	200146-00
2.....	2 .....	3/8" X 1 1/4" BOLT .....	350056-00
3.....	8 .....	1/2" x 1 1/2" BOLT .....	350095-00
4.....	2 .....	1/2" x 4 1/2" BOLT .....	350106-00
5.....	2 .....	#10 x 3/4" SELF DRILLING SCREW.....	350247-35
6.....	2 .....	3/8" HEX NUT.....	350254-00
7.....	6 .....	1/2" HEX NUT.....	350258-00
8.....	2 .....	3/8" LOCK WASHER.....	350305-00
9.....	4 .....	7/16" LOCK WASHER.....	350307-00
10.....	16 .....	1/2" SAE WASHER.....	350308-20
11.....	1 .....	1/2" FLAT WASHER .....	350308-00
12.....	10 .....	1/2" LOCK WASHER .....	350309-00
13.....	2 .....	RING.....	350520-00
14.....	4 .....	M10 x 1.5 NUT.....	356230-00
15.....	2 .....	LOCK PIN.....	A000008
16.....	1 .....	WIRE PLUG PLATE .....	A003801
17.....	2 .....	ARM.....	C002383
18.....	4 .....	1 1/2" x 2" THREADED BACKING PLATE W/ 12" ROD.....	C001438
19.....	1 .....	DRIVER SIDE BRACE .....	C003734
20.....	1 .....	PASSENGER SIDE BRACE.....	C003735
21.....	1 .....	MAIN RECEIVER .....	C003741
22.....	1 .....	7" ZIP TIE .....	300140-8



# BASEPLATE KIT INSTALLATION INSTRUCTIONS

**KIT# 521883-5**

05/31/23  
KS

ROADMASTER, Inc. 6110 NE 127th Ave. Vancouver, WA 98682 360-896-0407 fax 360-735-9300 www.roadmasterinc.com

This is one of our direct-connect series, which allows the visible front portion of to be easily removed from the front of the vehicle (Fig.A and Fig.B). The kit consists of a main receiver brace, two removable front braces, and a hardware pack.

The main receiver brace mounts to the frame. The removable front braces install in the main receiver brace.

Before starting the installation, lay out the kit components in order, as they will be used. This will give you a visual idea of how the components work, and will also confirm that everything is present and accounted for.



**IMPORTANT:** All baseplates **must** be assembled with all the bolts left loose for final adjustment and positioning (before tightening) unless otherwise instructed. All bolts **must** be torqued for proper strength. If more than one bolt is used per fastening point, the diagram may only show one. Use flat washers over all slotted holes and lock washers on all fasteners.

## WARNING

Failure to heed these warnings or follow the installation instructions may result in a voided warranty, loss of towed vehicle, personal injury or death.

- Do not weld or modify this baseplate or its components. Welding or modification will void the warranty.
- Do not use this document as a basis to design/fabricate a baseplate, as it may not show all parts or structural components.
- We strongly recommend professional installation.
- If the towed vehicle has been in an accident, it must be properly repaired before attaching the baseplate. Do not install the baseplate if any structural frame damage is found.
- The installer must use all bolts and parts supplied. If running changes were made by the vehicle manufacturer after this kit was designed, some bolts or other fasteners may no longer be the correct size. It is the installer's responsibility to verify this kit is securely fastened to the vehicle.
- Use Loctite® Red on all bolts used to secure this baseplate. Torque all bolts to the specifications found at the end of these instructions. Do not over-torque the bolts or failure may occur.
- The installer must inspect the baseplate to ensure adequate clearance, particularly around hoses, air conditioner lines, radiators, etc. or non-warranty failure may result.
- Roadmaster manufactures many styles of baseplates. If your baseplate has removable arms, they must be removed before driving the vehicle, unless the arms can be pinned or padlocked in place. If not secured, the arms could vibrate out.
- Some motorhome chassis have such a tight turning radius that you can damage your motorhome, towed vehicle, tow bar or baseplate while turning sharply. Before getting on the road, test your turning radius in an empty parking lot. Turning too sharply could result in non-warranty damage to your towing system, motorhome and/or towed vehicle.
- Do not back up with the towed vehicle attached or non-warranty damage will occur to your towing system or vehicles.
- The safety cables must connect the towing vehicle to the towed vehicle frame to frame, with the cables crossed, with enough slack for sharp turns. See cable instructions for proper routing. Failure to do so will result in non-warranty damage and/or the loss of the towed vehicle.
- This kit is designed for use with ROADMASTER tow bars and ROADMASTER adapters only. Using this kit with other brands, without an approved ROADMASTER adapter, may result in non-warranty damage or injury.
- Receiver extensions and out-of-level towing situations of 3 inches or more. This can cause the system to swing much higher and lower, causing excessive strain on the tow bar, baseplate and frame. That can cause the towing system to fail, causing property damage, personal injury or even death. If you must use a receiver extension or drop hitch to tow, it will reduce your receiver's weight capacity by 1/3 to avoid damaging your system. Never use more than one extension and/or drop hitch, as this will void your warranty.
- Every 3,000 miles, the owner must inspect all mounting points for cracks or fatigue, and check the fasteners for proper torque, according to the bolt torque requirements chart on the last page of these instructions.
- The owner must follow the vehicle manufacturer's instructions to prepare the vehicle for towing. Failure to do so may cause severe damage to the vehicle.
- This baseplate is only warranted for the original installation. Installing a used baseplate on another vehicle is not recommended and will void the warranty.



# BASEPLATE KIT INSTALLATION INSTRUCTIONS

**KIT# 521883-5**

05/31/23  
KS

ROADMASTER, Inc. 6110 NE 127th Ave. Vancouver, WA 98682 360-896-0407 fax 360-735-9300 www.roadmasterinc.com



1. **Important:** Please use all supplied bolts and parts and read all instructions carefully before beginning this installation. The majority of questions you may have can be answered within the text, and proper installation will ensure safe and secure travel. Now, begin the installation by removing four 10mm (head) bolts attaching the upper grille to the core support (Fig.C).

2. On each side, lift up to release the upper grille from the plastic retainers (Fig.D) and pull straight out on the upper grille to detach it from the fascia clips (Fig.E).



3. On each side, remove four 10mm bolts attaching the headlight to the frame (Fig.F) and unplug the connector (Fig.G). Carefully set it aside for now.

4. On each side, remove four plastic pin fasteners, one 8mm (screw) and one plastic fastener attaching the fender liner to the fascia (Fig.H). *Note: Only three pin fasteners are shown in Figure H.*





# BASEPLATE KIT INSTALLATION INSTRUCTIONS

**KIT# 521883-5**

05/31/23  
KS

ROADMASTER, Inc. 6110 NE 127th Ave. Vancouver, WA 98682 360-896-0407 fax 360-735-9300 www.roadmasterinc.com



5. On each side, remove five screw fasteners attaching the fender liner to the body (Fig.I and J).

6. On each side, starting where the fender meets the bumper, pull out gently but firmly on the fender trim piece to release it from the three clips attaching it to the fascia (Fig.K). *Note: Use care to ensure you do not break the clips.* Now, disconnect the side marker lights (Fig.L). Continue to pull on the fender trim piece to release the three Christmas tree fasteners attaching it to the fender (Fig.M).



7. On each side, remove five plastic fasteners and one T25 Torx bolt attaching the splash shield to the fascia and fender liner (Fig.N – passenger side). Then, remove one plastic fastener in the middle of the splash shield. *Note: Once you remove the four plastic fasteners, the bottom fascia trim piece will fall off. Set it aside for replacement in a future step.*

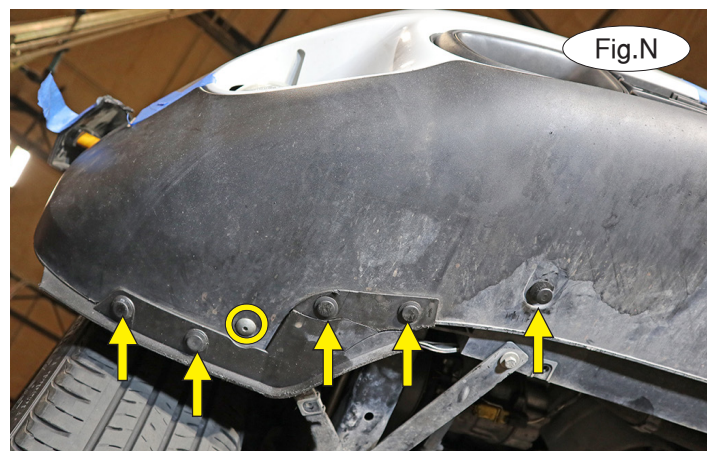
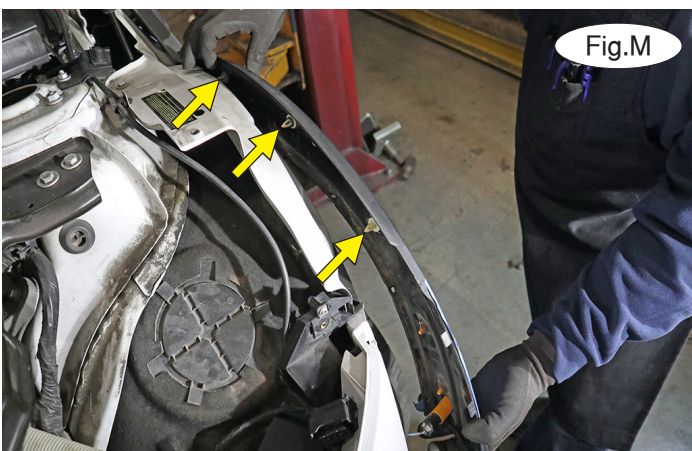



# BASEPLATE KIT INSTALLATION INSTRUCTIONS

**KIT# 521883-5**

05/31/23  
KS

ROADMASTER, Inc. 6110 NE 127th Ave. Vancouver, WA 98682 360-896-0407 fax 360-735-9300 www.roadmasterinc.com

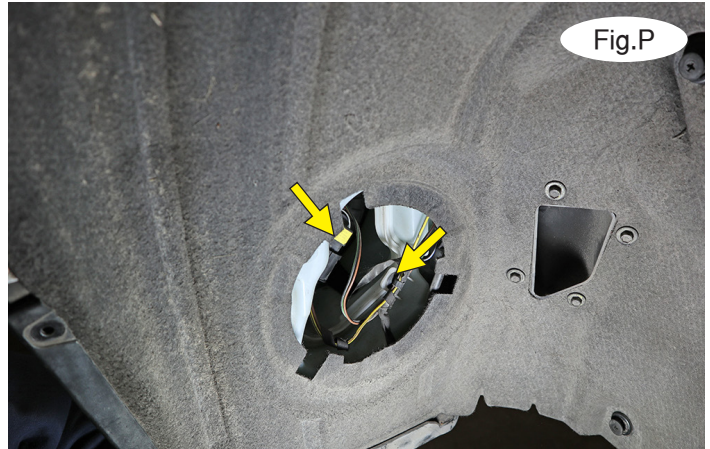

8. On each side, remove one T25 bolt attaching the top of the fascia to the core support (Fig.O). Then, remove the plastic access cover and disconnect the two fog light connectors, if the vehicle is so equipped (Fig.P).

9. On each side, pull out firmly on the center and the corners of the fascia to remove it (Fig.Q). Set it aside for now.

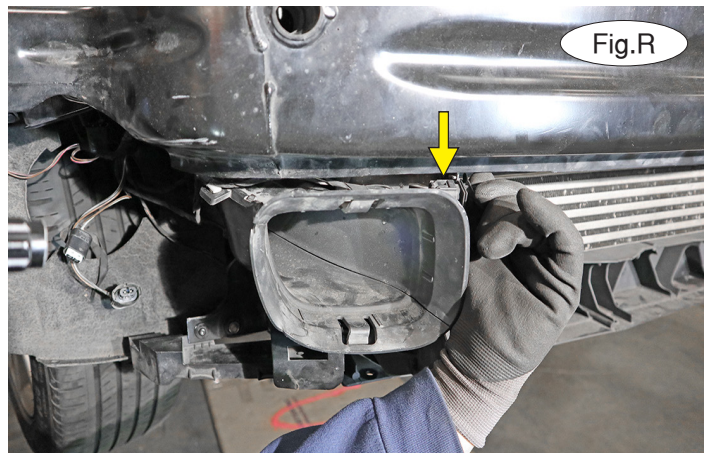

10. On the passenger side only, disconnect the ambient temperature sensor (Fig.R).

11. If the vehicle is so equipped, on each side, use a flathead screwdriver to pry the ducting apart and pull it forward to release it (Fig.S). Set the ducting aside for now.

12. On each side, remove three T15 Torx screws attaching the bumper to the frame (Fig.T – driver's side). *Note: The third screw is indicated in Figure T – inset.*

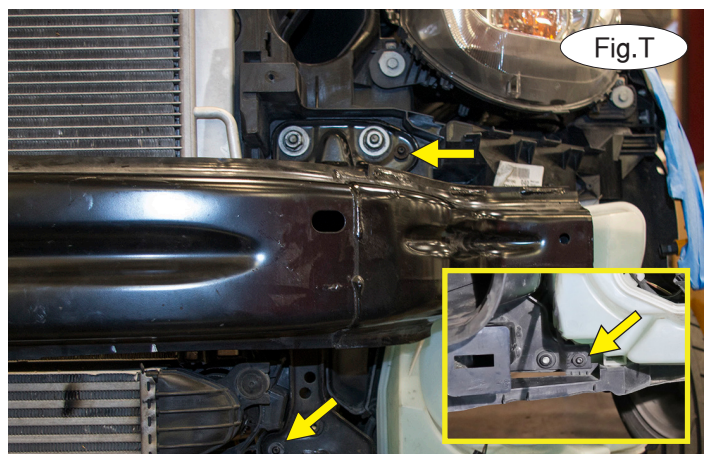



# BASEPLATE KIT INSTALLATION INSTRUCTIONS

**KIT# 521883-5**

05/31/23  
KS

ROADMASTER, Inc. 6110 NE 127th Ave. Vancouver, WA 98682 360-896-0407 fax 360-735-9300 www.roadmasterinc.com

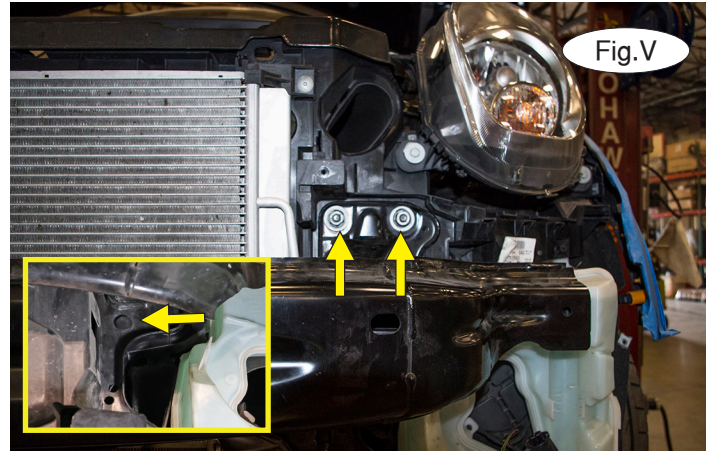
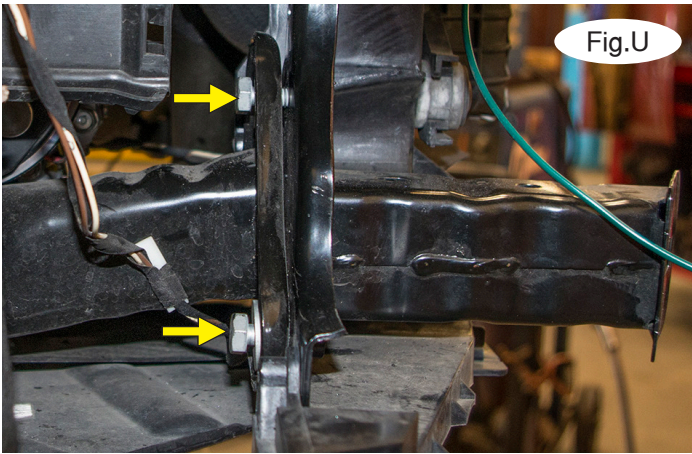

13. On the passenger side, remove two 13mm (head) bolts attaching the bumper to the frame (Fig.W). On the driver's side, access them from the underside (Fig.U). *Note: Use a standard wrench or ratchet to remove the bolts from behind.*

14. On each side, remove three 17mm nuts attaching the bumper core to the frame (Fig.V – driver's side). Remove the bumper core and set it aside. It will not be replaced.

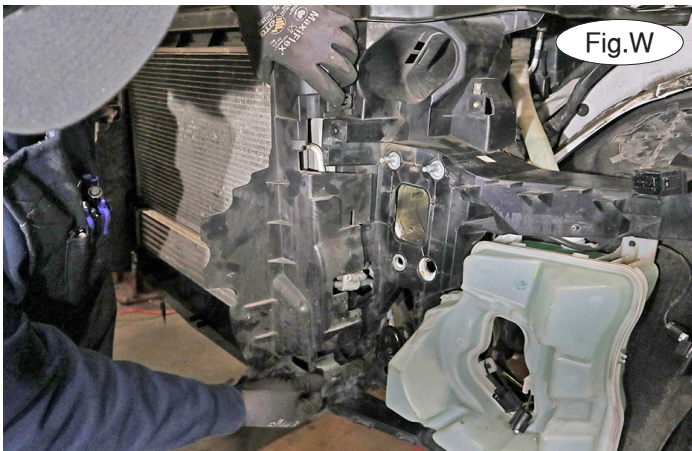

15. If the vehicle is so equipped, on each side, release the two clips attaching the air dam to the core support (Fig.W). They will not be replaced.

16. On each side, pull the fender liner away to provide access to the frame rail. Then, unplug the indicated harness (Fig.X).

17. Working on the driver's side only, use the drawing on page 1 as a reference to locate the driver's side brace. *Note: It is the brace with the holes that are in line. The passenger side brace has offset holes.* Place a 1/2" lock washer and 1/2" flat washer over a supplied 1/2" x 1 1/2" bolt and bolt through the rear mount of the driver's side brace. Then, insert one of the supplied 2" x 1 1/2" x 3/16" nutted backing plates with rod into the end of the frame rail and align it over the rearmost access hole. Bolt through the frame and into the backing plate using your prepared 1/2" bolt (Fig.Y). Leave finger tight for now.



All illustrations and specifications contained herein are based on the latest information available at the time of publication approval. ROADMASTER, INC. reserves the right to make changes at any time without notice in material, specification and models or to discontinue models.



# BASEPLATE KIT INSTALLATION INSTRUCTIONS

KIT# 521883-5

05/31/23  
KS

ROADMASTER, Inc. 6110 NE 127th Ave. Vancouver, WA 98682 360-896-0407 fax 360-735-9300 www.roadmasterinc.com



18. Place a  $\frac{1}{2}$ " lock washer and  $\frac{1}{2}$ " flat washer over a supplied  $\frac{1}{2}$ " x  $1\frac{1}{2}$ " bolt and bolt through the forward mount of the driver's side brace. Then, insert one of the supplied 2" x  $1\frac{1}{2}$ " x  $\frac{3}{16}$ " nutted backing plates with rod into the end of the frame rail and align it over the forwardmost access hole. Bolt through the frame and into the backing plate using your prepared  $\frac{1}{2}$ " bolt (Fig.Z). Leave finger tight for now.

19. Repeat steps 19 and 20 for the passenger side but note that there is a plate inside the frame rail that may impede your ability to reach the rear hole with the nutted backing plate. Bend the rod as needed to ensure that it clears that plate before it settles over the rearmost hole (Fig.AA).

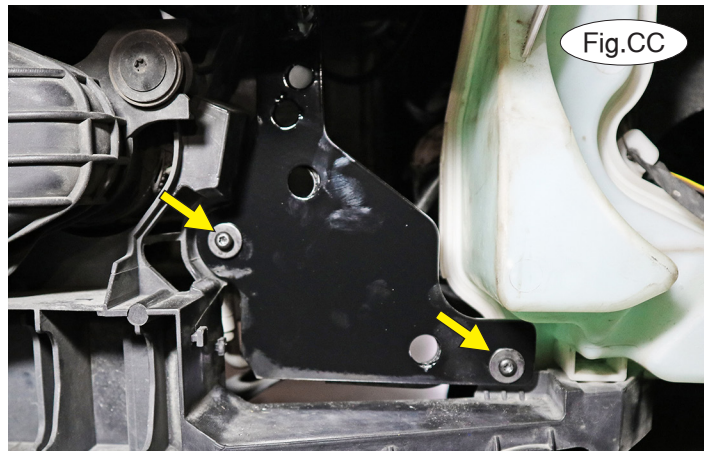

20. With the assistance of a second person, place the main brace over the bumper core mounts. On each side, use two of the supplied M10 lock washers and M10 nuts to attach the baseplate to the bumper core mount (Fig.BB).

21. Replace the three T15 screws you removed in step 12 (Fig.CC). *Note: The third screw is not visible in Figure CC but is located to the outside of the nuts you installed in the previous step.*

22. Working on one side at a time, locate the two 17mm bolts on the bottom of the frame rail. **Loosen them only** to allow movement for future hole alignment (Fig.DD).





# BASEPLATE KIT INSTALLATION INSTRUCTIONS

**KIT# 521883-5**

05/31/23  
KS

ROADMASTER, Inc. 6110 NE 127th Ave. Vancouver, WA 98682 360-896-0407 fax 360-735-9300 www.roadmasterinc.com

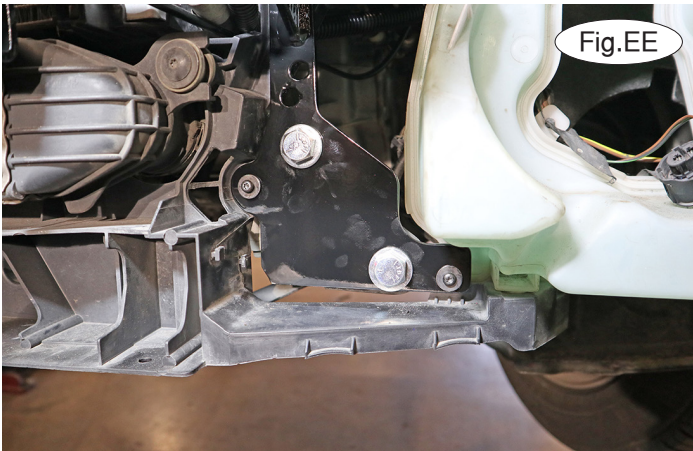

23. Use the two supplied  $\frac{1}{2}$ " x  $1\frac{1}{2}$ " bolts and  $\frac{1}{2}$ " flat washers to attach the lower arm of the main brace to the frame (Fig. EE). Finish with a  $\frac{1}{2}$ " flat washer,  $\frac{1}{2}$ " lock washer and  $\frac{1}{2}$ " nut.

24. Use the supplied  $\frac{3}{8}$ " x  $1\frac{1}{4}$ " bolt and  $\frac{3}{8}$ " lock washer to attach the lower arm of the main brace to the radiator support (Fig.FF). Finish with a  $\frac{3}{8}$ " flat washer and  $\frac{3}{8}$ " nut.

25. Using the supplied  $\frac{1}{2}$ " x  $4\frac{1}{2}$ " bolt and  $\frac{1}{2}$ " flat washer, bolt through the remaining mount of the front brace, through the pipe spacer on the side brace, and finish with a  $\frac{1}{2}$ " flat washer,  $\frac{1}{2}$ " lock washer and  $\frac{1}{2}$ " nut (Fig.GG). *Note: On the passenger side, you will need to install one additional  $\frac{1}{2}$ " large flat washer on the pipe spacer before you bolt through (Fig. GG – arrow).*



26. Place Loctite® Red on all bolts and then, beginning with the  $4\frac{1}{2}$ " bolts, tighten all bolts to the bolt torque requirements found at the end of these instructions. Then, place Loctite on all of the side brace bolts and tighten to the bolt torque requirements.

27. Now, on each side, tighten the 17mm bolts that you loosened in step 22.

28. On each side, replace the ducts that you removed in step 11. Use the provided holes on the front of the baseplate to remount each piece (Fig.HH). Then, zip tie the ambient temperature sensor to the crossbar of the main brace.

29. On each side, trim the fascia as shown in Figure II to allow clearance for the main brace.





# BASEPLATE KIT INSTALLATION INSTRUCTIONS

**KIT# 521883-5**

05/31/23  
KS

ROADMASTER, Inc. 6110 NE 127th Ave. Vancouver, WA 98682 360-896-0407 fax 360-735-9300 www.roadmasterinc.com

- 30. Reinstall the fascia, reversing steps 1 through 9.
- 31. On each side, insert the removable front arm into the front receiver 90 degrees from its final towing position, depressing the spring-loaded pin against the receiver. Twist back 90 degrees until the spring-loaded pin snaps into place in the notch on the receiver, locking the arm into place in its final towing position. **Please note: It is the owner's responsibility to ensure the locking of the pins before towing. Otherwise, failure of the towing system will result.**
- 32. Install the tow bar to the baseplate according to the manufacturer's instructions.



### **IMPORTANT!**

**Safety cables are required by law. When towing, connect safety cables to the safety cable tabs illustrated on the separate insert with the drawing and parts list and in Figure JJ. Make certain there is adequate slack in the cables to allow a full turning radius; otherwise, damage will result. If necessary, longer cables or cable extensions are available.**

### Three options for attaching the wiring plug to the main receiver brace

**For six-wire plugs:** Use the two supplied 3/4" self-tapping screws to attach the electrical plug directly to the rods on the front of the main receiver brace.

**For four-wire round plugs:** Attach to the plug mounting plate and then use the two supplied 3/4" self-tapping screws to attach the mounting plate to the rods on the front of the main receiver brace.

**For four-wire flat plugs:** Place the plug through the mounting plug plate, and then secure it using the supplied zip tie on the front of the plug (Fig.KK). Use the two supplied 3/4" self-tapping screws to attach the mounting plate to the rods on the front of the main receiver brace.

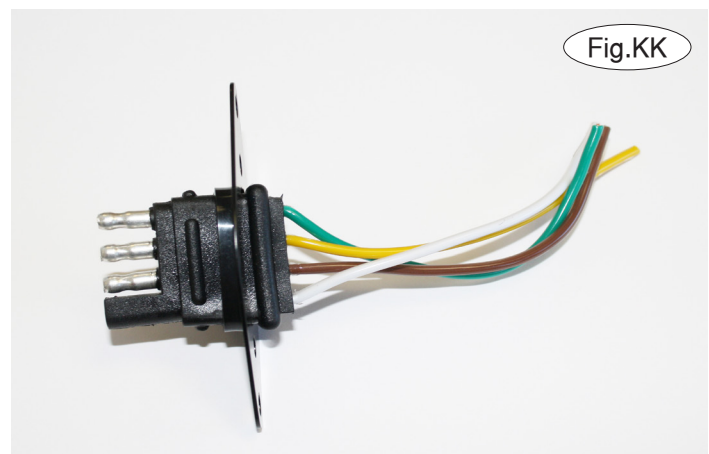

### **BOLT TORQUE REQUIREMENTS**

Note: The torque values represented below are intended as general guidelines. Torque requirements for specific applications may vary. Roadmaster does not warrant this information to be accurate for all applications and disclaims all liability for any claims or damages which may result from its use.

#### STANDARD BOLTS

Thread Size	Grade	Torque
5/16.....	5.....	13 ft./lb.
3/8.....	5.....	23 ft./lb.
7/16.....	5.....	37 ft./lb.
1/2.....	5.....	56 ft./lb.
5/8.....	5.....	150 ft./lb.

#### METRIC BOLTS

Thread Size	Grade	Plated / Unplated
8mm-1.0 .....	8.8 .....	20 ft./lb. 18 ft./lb.
8mm-1.25 .....	8.8 .....	19 ft./lb. 18 ft./lb.
10mm-1.25 .....	8.8 .....	38 ft./lb. 36 ft./lb.
10mm-1.5 .....	8.8 .....	37 ft./lb. 35 ft./lb.

#### METRIC BOLTS

Thread Size	Grade	Plated / Unplated
12mm-1.25 .....	8.8 .....	70 ft./lb. 65 ft./lb.
12mm-1.5 .....	8.8 .....	66 ft./lb. 61 ft./lb.
12mm-1.75 .....	8.8 .....	65 ft./lb. 60 ft./lb.
14mm-2.0 .....	8.8 .....	104 ft./lb. 97 ft./lb.

All illustrations and specifications contained herein are based on the latest information available at the time of publication approval. ROADMASTER, INC. reserves the right to make changes at any time without notice in material, specification and models or to discontinue models.