



# BASEPLATE KIT INSTALLATION INSTRUCTIONS

**KIT# 52266-5**

08/18/08

KS

ROADMASTER, Inc. 6110 NE 127th Ave. Vancouver, WA 98682 1-800-669-9690 fax 360-735-9300 www.roadmasterinc.com

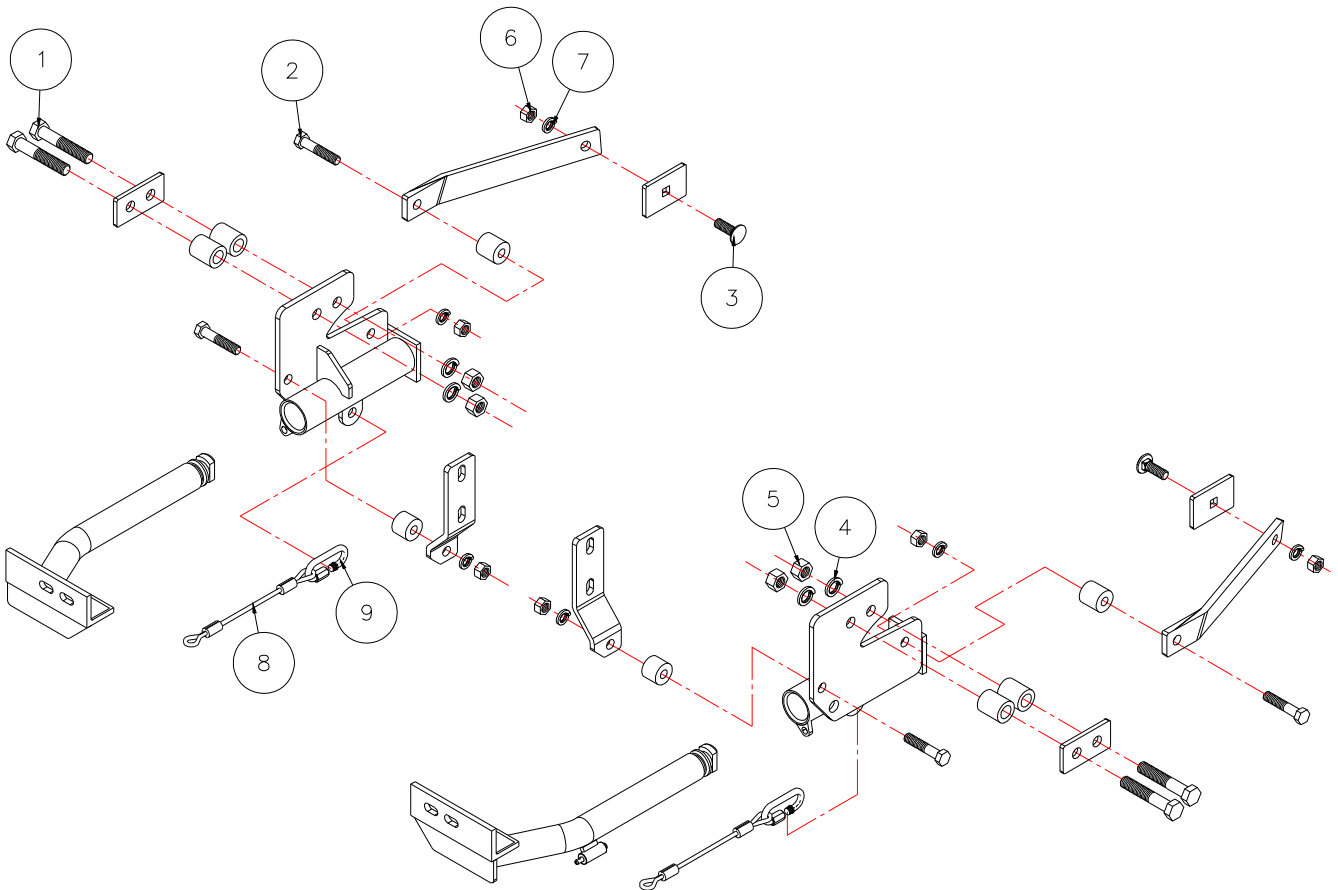

ITEM	QTY	Length	Width	HARDWARE	PART NO.
1	4	3 1/2"	5/8"	5/8" x 3 1/2" BOLT	350163-00
2	4	2 1/2"	1/2"	1/2" x 2 1/2" BOLT	350099-00
3	2	1 1/2"	1/2"	1/2" x 1 1/2" CARRIAGE BOLT	350362-00
4	4	5/8"		LOCK WASHER	350313-00
5	4	5/8"		NUT	350262-00
6	6	1/2"		NUT	350258-00
7	6	1/2"		LOCK WASHER	350309-00
8	2	13"		SAFETY CABLES, 8,000 lb. rated	650648-13
9	2			CABLE CONNECTORS	200008-00

ROADMASTER, INC.



# BASEPLATE KIT INSTALLATION INSTRUCTIONS

**KIT# 52266-5**

08/18/08

KS

ROADMASTER, Inc. 6110 NE 127th Ave. Vancouver, WA 98682 1-800-669-9690 fax 360-735-9300 www.roadmasterinc.com

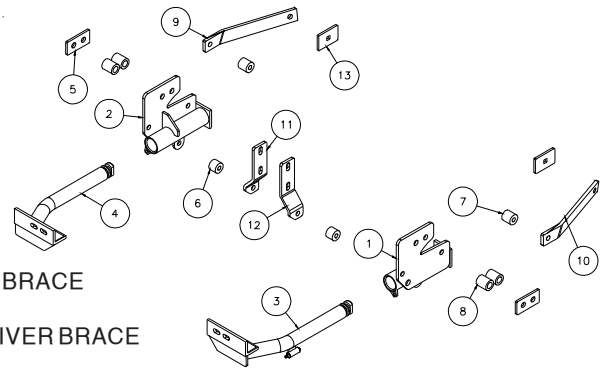

ITEM	QTY	PART NO.	ASSEMBLY
1	1	C-000730	DRIVER SIDE RECEIVER BRACE
2	1	C-000731	PASSENGER SIDE RECEIVER BRACE
3	1	C-000732	DRIVER SIDE ARM BRACE WELDMENT
4	1	C-000733	PASSENGER SIDE ARM BRACE WELDMENT
5	2	A-000968	3 1/2" x 1 3/4" BACKING PLATE
6	2	A-000880	1 1/4" O.D. x 1" TUBE
7	2	A-000856	1 1/4" x 1 1/4" TUBE
8	4	A-000518	1 1/4" O.D. x 1 1/2" ROUND TUBE
9	1	B-000399	PASSENGER SIDE REAR MOUNTING PLATE
10	1	B-000398	DRIVER SIDE REAR MOUNTING PLATE
11	1	B-000397	PASSENGER SIDE BRACE PLATE
12	1	B-000396	DRIVER SIDE BRACE PLATE
13	2	A-000050	2" x 3" SQ. HOLE BACKING PLATE

**IMPORTANT:** All baseplates **must** be assembled with all the bolts left loose for final adjustment and positioning (before tightening) unless otherwise instructed. All bolts **must** be torqued for proper strength. If more than one bolt is used per fastening point, the diagram may only show one.

- Use flat washers over all slotted holes
- Use lock washers on all fasteners

## WARNING

Failure to follow the below warnings and the installation instructions may result in voiding your warranty, property damage, the loss of your towed vehicle, personal injury or even death.

- We strongly recommend professional installation.
- The installer must read the instructions and use all bolts and parts supplied.
- Use **Loctite® Red** on all bolts used to secure this baseplate. Torque all bolts to the specifications found at the end of these instructions. Do not over-torque the bolts or failure may occur.
- Every 3,000 miles, the owner must inspect the fasteners for proper torque, according to the bolt torque requirements chart on the last page of these instructions. The owner must also inspect all mounting points for cracks or other signs of fatigue every 3,000 miles.
- The owner must check the vehicle manufacturer's instructions for the proper procedure(s) to prepare the vehicle for towing. Some vehicles must be equipped with a transmission lube pump, an axle disconnect, driveline disconnect or free-wheeling hubs before they can be towed. Failure to properly equip the vehicle will cause severe damage to the transmission.
- Do not weld. This baseplate is designed to be bolted to the vehicle. Welding will void the warranty.
- Do not use this document for custom fabrication, as it may not show all parts or structural components could result in loss of the towed vehicle.
- If the towed vehicle has been in an accident, it must be properly repaired before attaching the baseplate. Do not install the baseplate if any structural frame damage is found.
- If running changes were made by the vehicle manufacturer after this kit was designed, some bolts or other fasteners in the hardware pack may no longer be the correct size. It is the installer's responsibility to verify this kit is securely fastened to the vehicle and fitted with the correct hardware to account for these changes.
- Roadmaster manufactures many styles of baseplates. If your baseplate has removable arms, they must be removed before driving the vehicle, unless the arms can be pinned or padlocked in place. If not secured, the arms could vibrate out.
- Some motorhome chassis have such a tight turning radius that you can damage your motorhome, towed vehicle, tow bar or baseplate while turning sharply. Before getting on the road, test your turning radius in an empty parking lot. Turning too sharply could result in non-warranty damage to towing system, motorhome and/or towed vehicle.
- Do not back up with the towed vehicle attached or non-warranty damage will occur to your towing system, motorhome and/or towed vehicle.
- The safety cables must connect the towing vehicle to the towed vehicle frame to frame, with the cables crossed, with enough slack for sharp turns. Refer to the cable instructions for proper routing. Failure to leave enough slack in the safety cables, or failure to connect the safety cables frame to frame, will result in the loss of the towed vehicle.
- This kit is designed for use with ROADMASTER tow bars and ROADMASTER adapters only. Using this kit with other brands, without an approved ROADMASTER adapter, may result in non-warranty damage or injury.
- Upon final installation, the installer must inspect the baseplate to ensure adequate clearance, particularly around hoses, air conditioner lines, radiators, etc.
- This baseplate is only warranted for the original installation. Installing a used baseplate on another vehicle is not recommended and will void the warranty.

ROADMASTER, INC.



# BASEPLATE KIT INSTALLATION INSTRUCTIONS

**KIT# 52266-5**

08/18/08

KS

ROADMASTER, Inc. 6110 NE 127th Ave. Vancouver, WA 98682 1-800-669-9690 fax 360-735-9300 www.roadmasterinc.com

1. This bracket kit is one of our EZ series with removable front braces. The kit consists of two rear receiver braces which mount inside the front frame tubes, two inner braces, two rear braces and removable front braces (Fig.A). Everything but the front arm braces install behind the bumper fascia. The front bumper will have to be removed for the installation.



2. **Important: please use all supplied bolts and parts and read all instructions carefully before beginning this**

**installation. The majority of questions you may have can be answered within the text, and proper installation will ensure safe and secure travel.** Now, begin the installation. Disconnect the fog lights if present (Fig.B) then remove four bolts, two on the top of each frame tube (Fig.C). Now, remove two bolts on the bumper side braces on each side. These are located on the sides of the frame tubes.

3. Use two screwdrivers to pop the plastic fasteners loose on the bottom radiator flap, pull free and set aside.

4. Mark the frame where the bumper brackets are located so that the bumper can be repositioned to the same spot. Remove the shoulder nuts inside each frame tube holding the bumper brackets. This is where the new inside braces will be mounted (Fig.D).

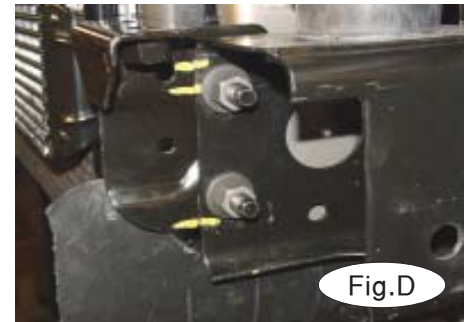
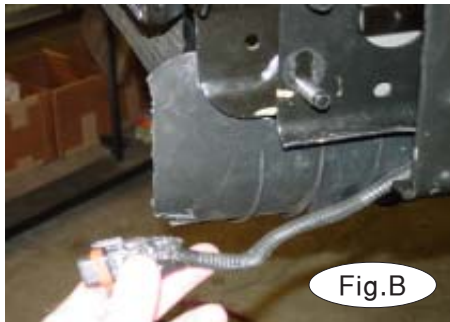

5. Working on one side at a time, look back about a foot from the front of the frame and locate a slotted hole in the side of the frame. Fish wire a  $\frac{1}{2}$ " x  $1\frac{1}{2}$ " carriage bolt and  $\frac{1}{4}$ " x 2" x 3" backing plate through the front of the frame into the slotted hole (Fig.E,F).





# BASEPLATE KIT INSTALLATION INSTRUCTIONS

**KIT# 52266-5**

08/18/08

KS

ROADMASTER, Inc. 6110 NE 127th Ave. Vancouver, WA 98682 1-800-669-9690 fax 360-735-9300 www.roadmasterinc.com

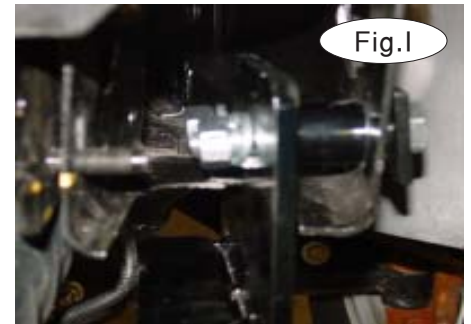

6. Working on one side at a time, look back about a foot from the front of the frame and locate a slotted hole in the side of the frame. Fishwire a  $\frac{1}{2}$ " x  $1\frac{1}{2}$ " carriage bolt and  $\frac{1}{4}$ " x 2" x 3" backing plate through the front of the frame into the slotted hole (Fig.E,F).

7. Bolt through the rear brace with a  $\frac{1}{2}$ " nut and lock washer (Fig.G).

8. Enlarge the mounting holes in a bumper side brace then assemble the side brace, two  $\frac{5}{8}$ " x  $3\frac{1}{2}$ " bolts, and spacers as shown in (Fig.H).

9. Bolt through the receiver brace and frame and finish with  $\frac{1}{2}$ " nuts and lock washers (Fig.I).

10. Put the inner brace over the bumper bracket bolts and secure with the original shoulder nuts as shown (Fig.J).

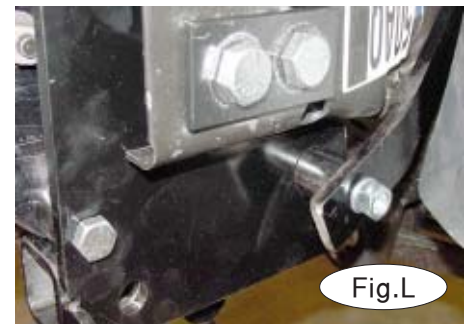
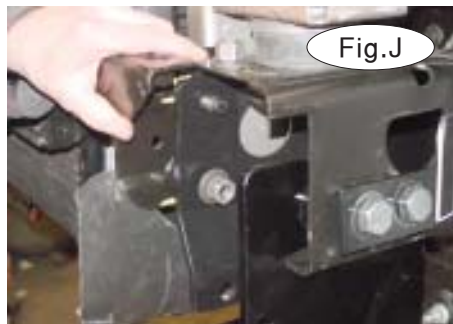

11. Bolt through the bottom of the inner brace and receiver brace with a  $\frac{1}{2}$ " x  $2\frac{1}{2}$ " bolt,  $1\frac{1}{4}$ " spacer, lock washer and nut (Fig.K).

12. Bolt the receiver brace to the rear brace with a  $\frac{1}{2}$ " x  $2\frac{1}{2}$ " bolt,  $1\frac{1}{4}$ " spacer, flat washers and lock washer and nut (Fig.L).

13. Repeat steps 2 through 11 for the remaining side.



# BASEPLATE KIT INSTALLATION INSTRUCTIONS

**KIT# 52266-5**

08/18/08

KS

ROADMASTER, Inc. 6110 NE 127th Ave. Vancouver, WA 98682 1-800-669-9690 fax 360-735-9300 www.roadmasterinc.com

R O A D M A S T E R, I N C.

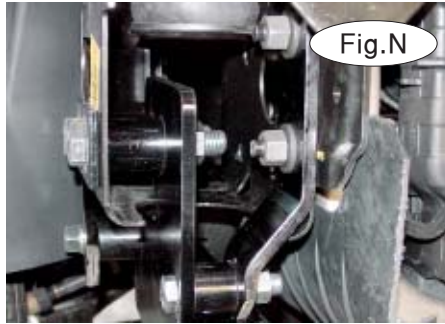
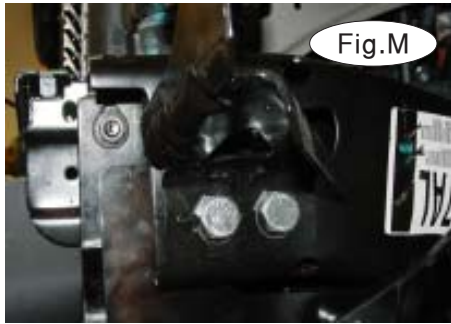

14. Level and align the receiver braces to each other (Fig.M) and tighten two outside frame bolts (Fig.N) on each side.
15. Align the bumper braces to their original marks and tighten the shoulder nuts to hold position (Fig.N).
16. Torque all mounting bolts to the specifications on the next page.
17. Replace the bumper and fascia reversing steps 2 to 3.
18. Insert the front arm braces into the receiver braces at a 90 degree angle (Fig.O) then twist 90 degrees to lock in place ( Fig.P).
19. Install the tow bar according to the manufacturer's instructions.
20. Attach one end of the 13" safety cables to the front holes on the receiver braces (Fig.Q) and the other end to the tow vehicle's safety cables and tow bar. *Note:* hole placement on the receivers may vary from what is depicted here on later bracket kits.



## BOLT TORQUE REQUIREMENTS

Note: The torque values represented below are intended as general guidelines. Torque requirements for specific applications may vary. Roadmaster does not warrant this information to be accurate for all applications and disclaims all liability for any claims or damages which may result from its use.

STANDARD BOLTS			METRIC BOLTS			METRIC BOLTS		
Thread Size	Grade	Torque	Thread Size	Grade	Plated/Unplated	Thread Size	Grade	Plated/Unplated
5/16	5	13 ft./lb.	8mm-1.0	8.8	20 ft./lb. 18 ft./lb.	12mm-1.25	8.8	70 ft./lb. 65 ft./lb.
3/8	5	23 ft./lb.	8mm-1.25	8.8	19 ft./lb. 18 ft./lb.	12mm-1.5	8.8	66 ft./lb. 61 ft./lb.
7/16	5	37 ft./lb.	10mm-1.25	8.8	38 ft./lb. 36 ft./lb.	12mm-1.75	8.8	65 ft./lb. 60 ft./lb.
1/2	5	56 ft./lb.	10mm-1.5	8.8	37 ft./lb. 35 ft./lb.	14mm-2.0	8.8	104 ft./lb. 97 ft./lb.
5/8	5	150 ft./lb.						

All illustrations and specifications contained herein are based on the latest information available at the time of publication approval. ROADMASTER, INC. reserves the right to make changes at any time without notice in material, specification and models or to discontinue models.