



# BASEPLATE KIT INSTALLATION INSTRUCTIONS

**KIT# 52289-4**

03/12/24  
KS

ROADMASTER, Inc. 6110 NE 127th Ave. Vancouver, WA 98682 360-896-0407 fax 360-735-9300 www.roadmasterinc.com

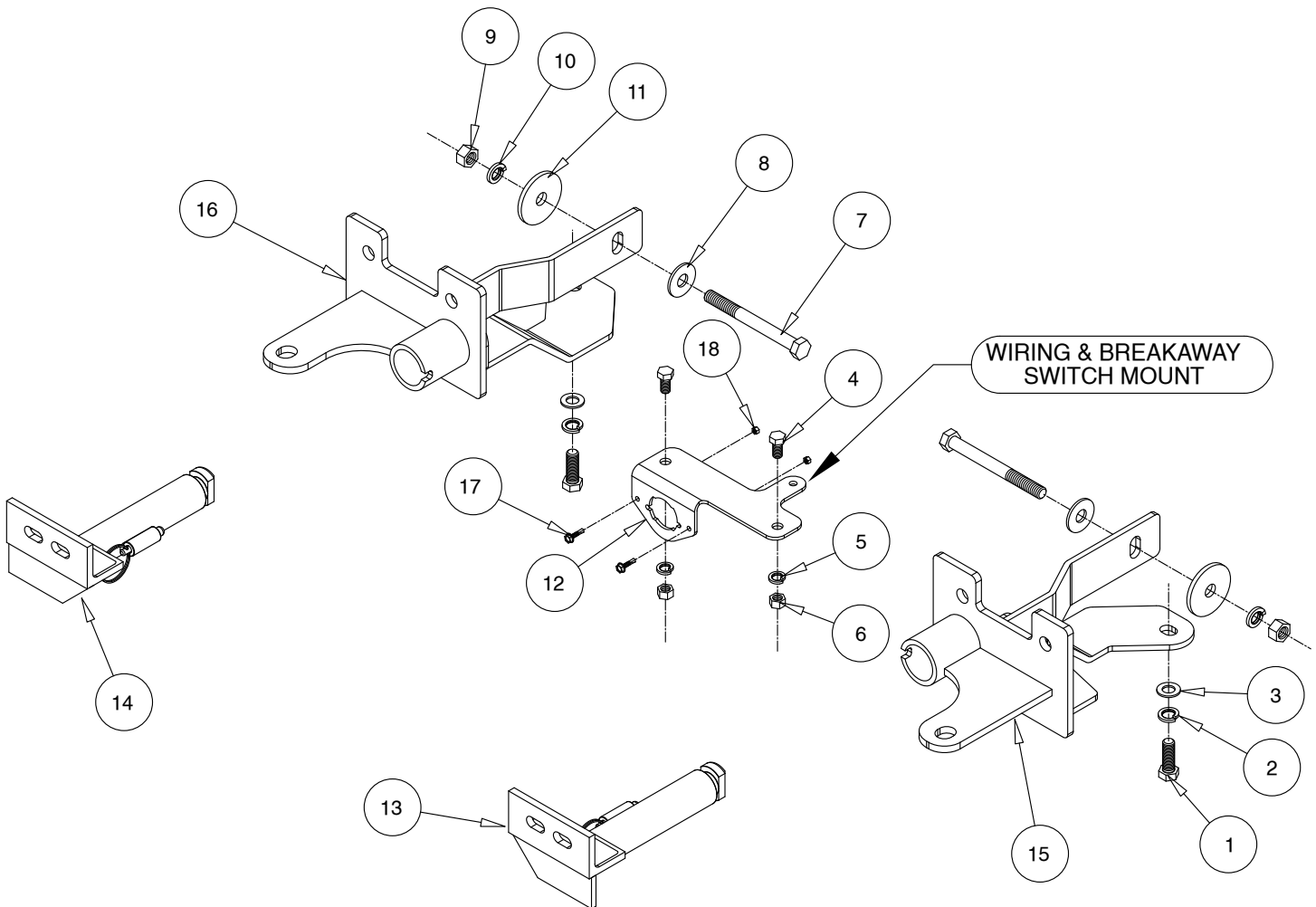

ITEM	QTY	NAME	PART #
1.....2.....		12mm x 1.5 x 35mm BOLT .....	357102-00
2.....2.....		12mm LOCK WASHER .....	355725-00
3.....2.....		12mm FLAT WASHER.....	355720-00
4.....2.....		3/8" x 3/4" BOLT.....	350053-00
5.....2.....		3/8" LOCK WASHER .....	350305-00
6.....2.....		3/8" NUT .....	350254-00
7.....2.....		1/2" x 5" BOLTS .....	350107-00
8.....2.....		1/2" FLAT WASHER .....	350308-00
9.....2.....		1/2" NUT .....	350258-00
10.....2.....		1/2" LOCK WASHER .....	350309-00
11.....2.....		1/2" PLATE WASHER.....	A003086
12.....1.....		WIRING AND BREAKAWAY MOUNT .....	B003091
13.....1.....		DRIVER SIDE ARM.....	C003007
14.....1.....		PASSENGER SIDE ARM .....	C003008
15.....1.....		DRIVER SIDE RECEIVER BRACE.....	C003009
16.....1.....		PASSENGER SIDE RECEIVER BRACE .....	C003010
17.....2.....		#10 x 1/2" SCREW .....	350389-00
18.....2.....		#10 NYLON INSERT LOCK NUT .....	350249-00



# BASEPLATE KIT INSTALLATION INSTRUCTIONS

**KIT# 52289-4**

03/12/24  
KS

ROADMASTER, Inc. 6110 NE 127th Ave. Vancouver, WA 98682 360-896-0407 fax 360-735-9300 www.roadmasterinc.com

This is one of our crossbar-style baseplates, which allows the visible front portion of the bracket to be easily removed from the front of the vehicle (Fig.A and Fig.B). The bracket consists of a two main receiver braces, two front removable braces and a hardware pack.

The main receiver brace mounts to the bumper support and tow hook supports. The removable front braces install in the main receiver brace.

Before starting the installation, lay out the kit components in order, as they will be used. This will give you a visual idea of how the components work, and will also confirm that everything is present and accounted for.



**IMPORTANT:** All baseplates **must** be assembled with all the bolts left loose for final adjustment and positioning (before tightening) unless otherwise instructed. All bolts **must** be torqued for proper strength. If more than one bolt is used per fastening point, the diagram may only show one. Use flat washers over all slotted holes and lock washers on all fasteners.

## **WARNING**

Failure to heed these warnings or follow the installation instructions may result in a voided warranty, loss of towed vehicle, personal injury or death.

- Do not weld or modify this baseplate or its components. Welding or modification will void the warranty.
- Do not use this document as a basis to design/fabricate a baseplate, as it may not show all parts or structural components.
- We strongly recommend professional installation.
- If the towed vehicle has been in an accident, it must be properly repaired before attaching the baseplate. Do not install the baseplate if any structural frame damage is found.
- The installer must use all bolts and parts supplied. If running changes were made by the vehicle manufacturer after this kit was designed, some bolts or other fasteners may no longer be the correct size. It is the installer's responsibility to verify this kit is securely fastened to the vehicle.
- Use Loctite® Red on all bolts used to secure this baseplate. Torque all bolts to the specifications found at the end of these instructions. Do not over-torque the bolts or failure may occur.
- The installer must inspect the baseplate to ensure adequate clearance, particularly around hoses, air conditioner lines, radiators, etc. or non-warranty failure may result.
- Roadmaster manufactures many styles of baseplates. If your baseplate has removable arms, they must be removed before driving the vehicle, unless the arms can be pinned or padlocked in place. If not secured, the arms could vibrate out.
- Some motorhome chassis have such a tight turning radius that you can damage your motorhome, towed vehicle, tow bar or baseplate while turning sharply. Before getting on the road, test your turning radius in an empty parking lot. Turning too sharply could result in non-warranty damage to your towing system, motorhome and/or towed vehicle.
- Do not back up with the towed vehicle attached or non-warranty damage will occur to your towing system or vehicles.
- The safety cables must connect the towing vehicle to the towed vehicle frame to frame, with the cables crossed, with enough slack for sharp turns. See cable instructions for proper routing. Failure to do so will result in non-warranty damage and/or the loss of the towed vehicle.
- This kit is designed for use with ROADMASTER tow bars and ROADMASTER adapters only. Using this kit with other brands, without an approved ROADMASTER adapter, may result in non-warranty damage or injury.
- Receiver extensions and out-of-level towing situations of 3 inches or more. This can cause the system to swing much higher and lower, causing excessive strain on the tow bar, baseplate and frame. That can cause the towing system to fail, causing property damage, personal injury or even death. If you must use a receiver extension or drop hitch to tow, it will reduce your receiver's weight capacity by 1/3 to avoid damaging your system. Never use more than one extension and/or drop hitch, as this will void your warranty.
- Every 3,000 miles, the owner must inspect all mounting points for cracks or fatigue, and check the fasteners for proper torque, according to the bolt torque requirements chart on the last page of these instructions.
- The owner must follow the vehicle manufacturer's instructions to prepare the vehicle for towing. Failure to do so may cause severe damage to the vehicle.
- This baseplate is only warranted for the original installation. Installing a used baseplate on another vehicle is not recommended and will void the warranty.



# BASEPLATE KIT INSTALLATION INSTRUCTIONS

**KIT# 52289-4**

03/12/24  
KS

ROADMASTER, Inc. 6110 NE 127th Ave. Vancouver, WA 98682 360-896-0407 fax 360-735-9300 www.roadmasterinc.com

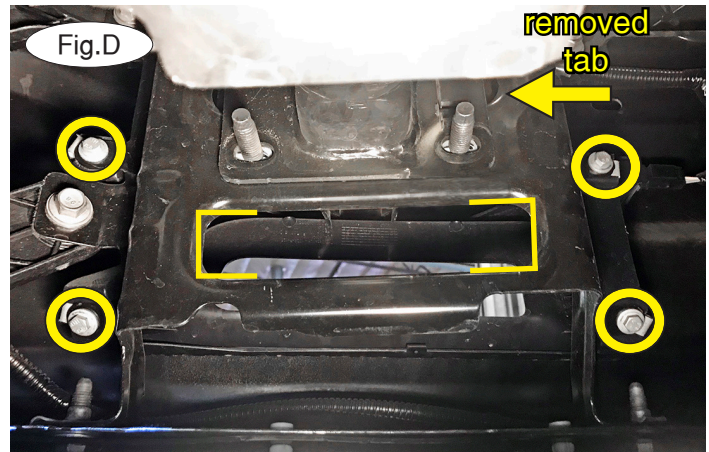
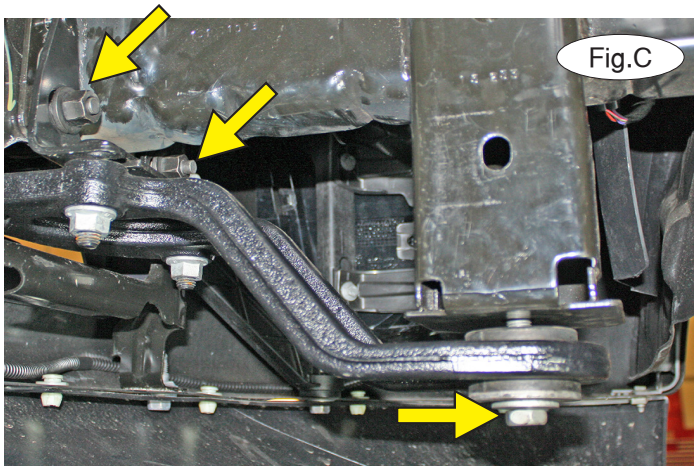

1. **Important:** please use all supplied bolts and parts and read all instructions carefully before beginning this installation. The majority of questions you may have can be answered within the text, and proper installation will ensure safe and secure travel. Now, begin the installation. **If the vehicle is not equipped with tow hooks:** proceed to the next step. **If the vehicle is equipped with tow hooks:** on each side, remove two 18mm (socket) nuts attaching the tow hook and bumper to the frame, and then remove the 18mm (head) bolt attaching the tow hook bracket to the frame (Fig.C). *Note:* retain the tow hooks for replacement in case the bracket is ever removed.



2. On each side, locate the tab near the bumper mounting studs. Use a hammer to flatten it, or a cut-off wheel to remove it (Fig.D – arrow). *Note:* Due to manufacturing variances, it may be necessary to square off the rear of the tow hook opening on each side in order to allow clearance for the main receiver brace.

3. It is necessary to either remove the grille inserts or trim them to allow clearance for the main receiver brace.

**If you choose to remove them:** remove four 10mm (head) bolts to remove the grille inserts indicated with yellow circles in Figure D. The inserts will not be replaced. Retain the grille inserts and hardware for replacement in case the bracket is ever removed.

**If you choose to trim the grille inserts:** cut out the template at the end of these instructions, align it with the bottom of the grille, and trim it as shown in Figure E. *Note:* You will also need to copy the profile of the trimming onto the bumper mounting opening to allow clearance for the main receiver brace.

**If you have factory tow hooks:** on each side, trim the front of the tow hook opening to allow for proper rotation on the barrel of the front braces (Fig.F).

4. Place the main receiver brace over the studs exposed in step 1 and replace the nuts.



# BASEPLATE KIT INSTALLATION INSTRUCTIONS

**KIT# 52289-4**

03/12/24  
KS

ROADMASTER, Inc. 6110 NE 127th Ave. Vancouver, WA 98682 360-896-0407 fax 360-735-9300 www.roadmasterinc.com

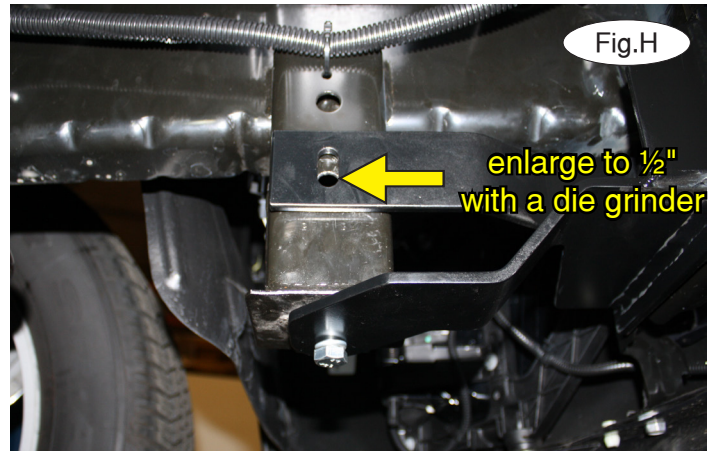
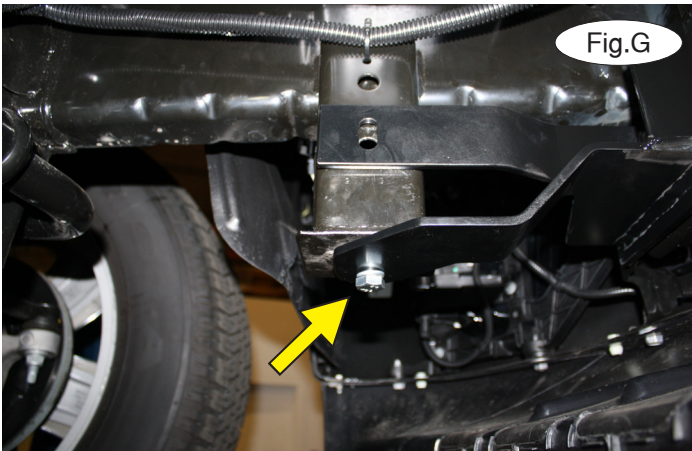

5. On each side, place a 12mm lock washer over a 12mm x 1.5 x 35mm bolt and bolt up through the lower mount of the main receiver brace and into the existing tow hook mount in the frame (Fig.G). *Note:* ensure proper alignment, as the bolts will receive Loctite® Red and will be torqued at the end of these instructions.

6. On each side, on the rear slotted hole, use a die grinder on each side of the frame to enlarge the existing openings to accommodate a 1/2" bolt (Fig.H).



7. On each side, place a 1/2" flat washer over a 1/2" x 5" bolt and bolt through the rear slotted hole, the main receiver brace and into the frame. Finish with a 1/2" plate washer, 1/2" lock washer and a 1/2" nut (Fig.I).

8. Torque all bolts to the bolt torque requirements found at the end of these instructions. *Note:* use Loctite® Red on all nuts and bolts.

9. ***Note: the next two images are for illustration purposes only, as your specific application may be slightly different.***

10. On each side, insert the removable front bracket arm into the front receiver 90 degrees from its final towing position, depressing the spring-loaded pin against the receiver (Fig.J). Now, twist back 90 degrees until the spring-loaded pin snaps into place in the notch on the receiver, locking the arm into place in its final towing position (Fig.K).

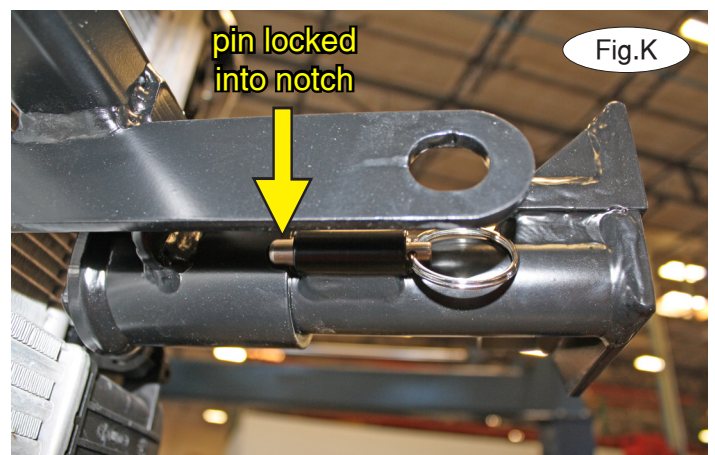

***Please note: it is the owner's responsibility to ensure the locking of the pins before towing. Otherwise, failure of the towing system will result.***



# BASEPLATE KIT INSTALLATION INSTRUCTIONS

**KIT# 52289-4**

03/12/24  
KS

ROADMASTER, Inc. 6110 NE 127th Ave. Vancouver, WA 98682 360-896-0407 fax 360-735-9300 www.roadmasterinc.com

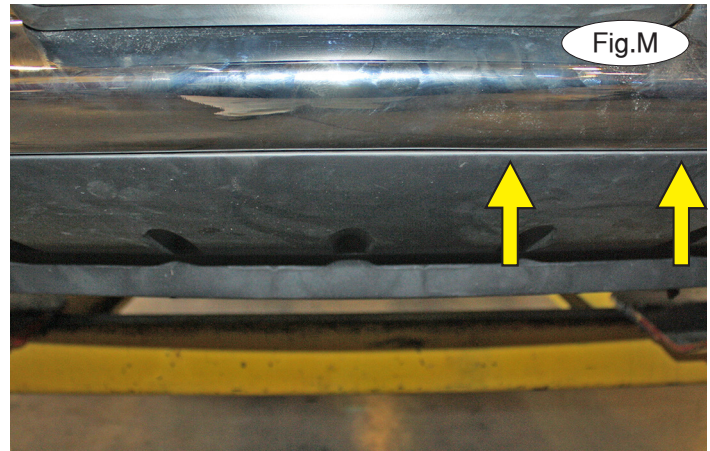
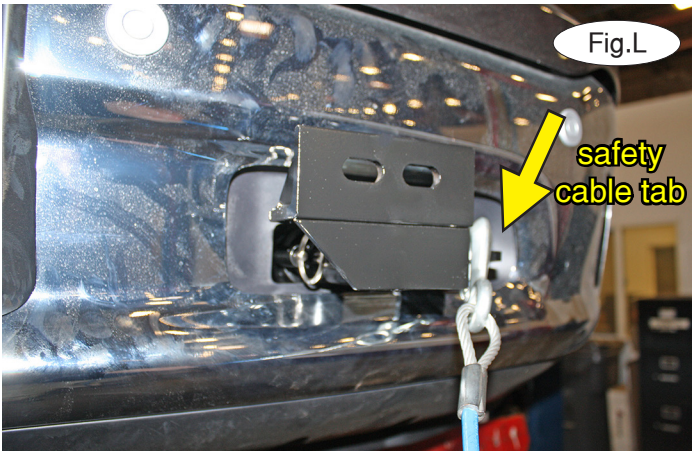

11. Install the tow bar to the mounting bracket according to the manufacturer's instructions.

### **IMPORTANT!**

**Safety cables are required by law. When towing, connect safety cables to the safety cable tabs shown in Figure L. Make certain there is adequate slack in the cables to allow a full turning radius; otherwise, damage will result. If necessary, longer cables or cable extensions are available.**

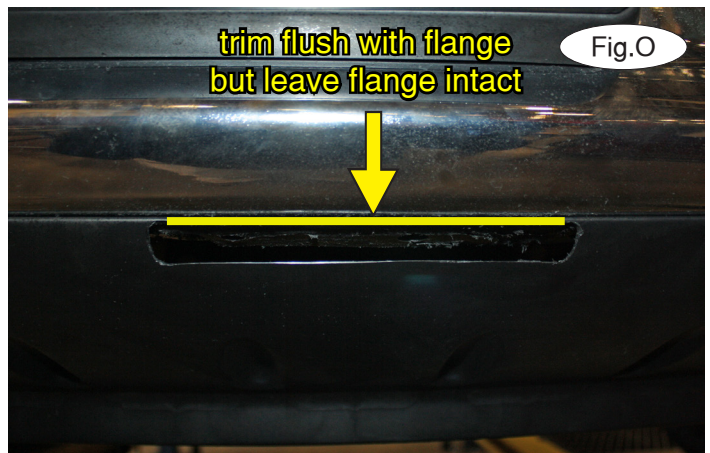
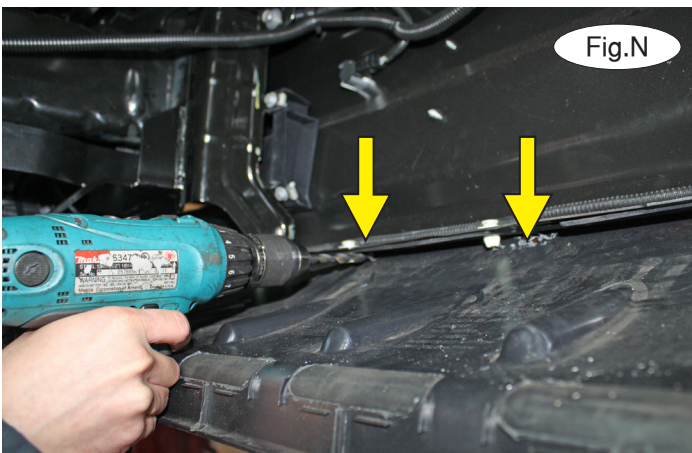

- 12. If you are using our included wiring and/or a breakaway bracket, the following steps will assist in its installation. You will be mounting the bracket in the location noted in Figure M, in line with the bottom right corner of the license plate.
- 13. Drill two pilot holes from the backside of the fascia. Locate one hole just to the right of the center fastener, and one just to the right of the next fastener to the left (Fig.N).
- 14. Trim out the section between the two pilot holes, cutting the upper edge of the opening flush with the flange but make certain to leave the flange intact (Fig.O). Remove the two locating fasteners.

All illustrations and specifications contained herein are based on the latest information available at the time of publication approval. ROADMASTER, INC. reserves the right to make changes at any time without notice in material, specification and models or to discontinue models.



# BASEPLATE KIT INSTALLATION INSTRUCTIONS

**KIT# 52289-4**

03/12/24  
KS

ROADMASTER, Inc. 6110 NE 127th Ave. Vancouver, WA 98682 360-896-0407 fax 360-735-9300 www.roadmasterinc.com

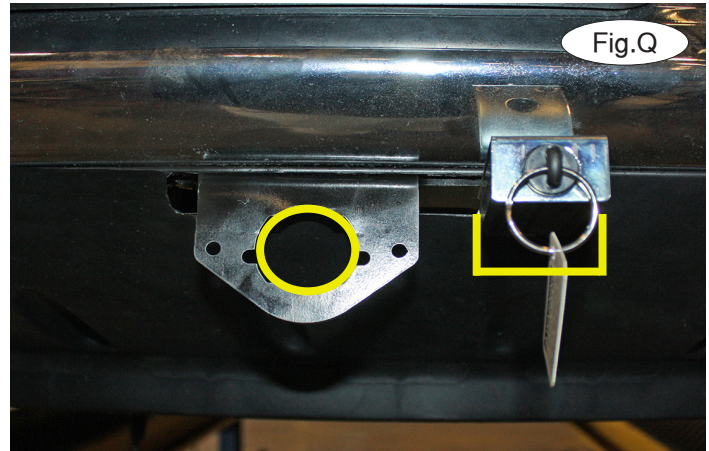
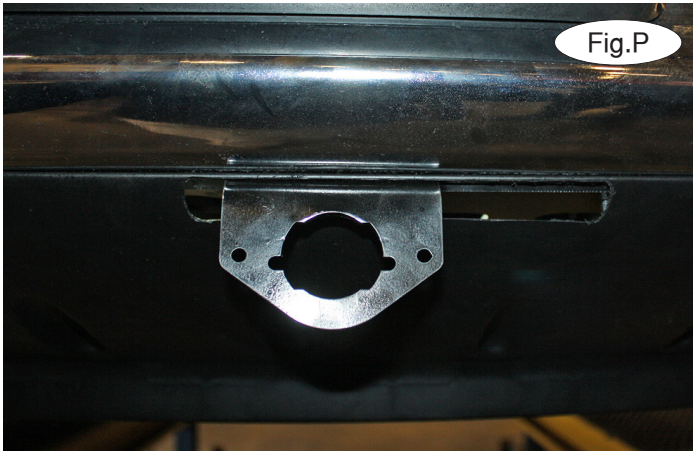

15. Place the wiring bracket over the fastener holes you exposed in the previous step. Pull down on the lower splash shield and on each side, bolt through the bracket, lower splash shield and bumper core using the supplied 3/8" x 3/4" bolt. Finish with a 3/8" lock washer and nut. Figure P shows the bracket installed.

16. The lower splash shield will need to be trimmed to allow clearance for the wiring plug, and the breakaway, if applicable. Use the yellow lines in Figure Q as a reference for the trimming patterns.

## Three options for attaching the wiring plug to the main receiver brace

**For six-wire plugs:** use the two supplied 3/4" self-tapping screws to attach the electrical plug directly to the rods on the front of the main receiver brace.

**For four-wire round plugs:** attach to the plug mounting plate and then use the two supplied 3/4" self-tapping screws to attach the mounting plate to the rods on the front of the main receiver brace.

**For four-wire flat plugs:** place the plug through the mounting plug plate, and then secure it using the supplied zip tie on the front of the plug (Fig.R). Use the two supplied 3/4" self-tapping screws to attach the mounting plate to the rods on the front of the main receiver brace.

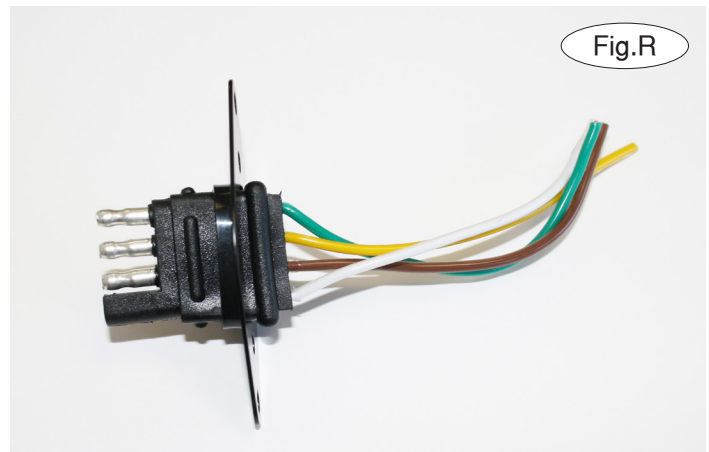

## BOLT TORQUE REQUIREMENTS

Note: The torque values represented below are intended as general guidelines. Torque requirements for specific applications may vary. Roadmaster does not warrant this information to be accurate for all applications and disclaims all liability for any claims or damages which may result from its use.

### STANDARD BOLTS

Thread Size	Grade	Torque
5/16-18	5	13 ft./lb.
3/8-16	5	23 ft./lb.
7/16-14	5	37 ft./lb.
1/2-13	5	57 ft./lb.
5/8-11	5	112 ft./lb.

### METRIC BOLTS

Thread Size	Grade	Torque
6mm-1.0	8.8	6 ft./lb.
8mm-1.0	8.8	18 ft./lb.
8mm-1.25	8.8	16 ft./lb.
10mm-1.25	8.8	36 ft./lb.
10mm-1.5	8.8	31 ft./lb.

### METRIC BOLTS

Thread Size	Grade	Torque
12mm-1.25	8.8	64 ft./lb.
12mm-1.5	8.8	60 ft./lb.
12mm-1.75	8.8	55 ft./lb.
14mm-2.0	8.8	88 ft./lb.

All illustrations and specifications contained herein are based on the latest information available at the time of publication approval. ROADMASTER, INC. reserves the right to make changes at any time without notice in material, specification and models or to discontinue models.



# BASEPLATE KIT INSTALLATION INSTRUCTIONS

**KIT# 52289-4**

03/12/24  
KS

ROADMASTER, Inc. 6110 NE 127th Ave. Vancouver, WA 98682 360-896-0407 fax 360-735-9300 www.roadmasterinc.com

*Grille insert  
trimming template*

