



BASEPLATE KIT INSTALLATION INSTRUCTIONS

KIT# 523114-1

01/26/05
RV

ROADMASTER, Inc. 6110 NE 127th Ave. Vancouver, WA 98682 1-800-669-9690 fax 360-735-9300 www.roadmasterinc.com

ROADMASTER, INC.

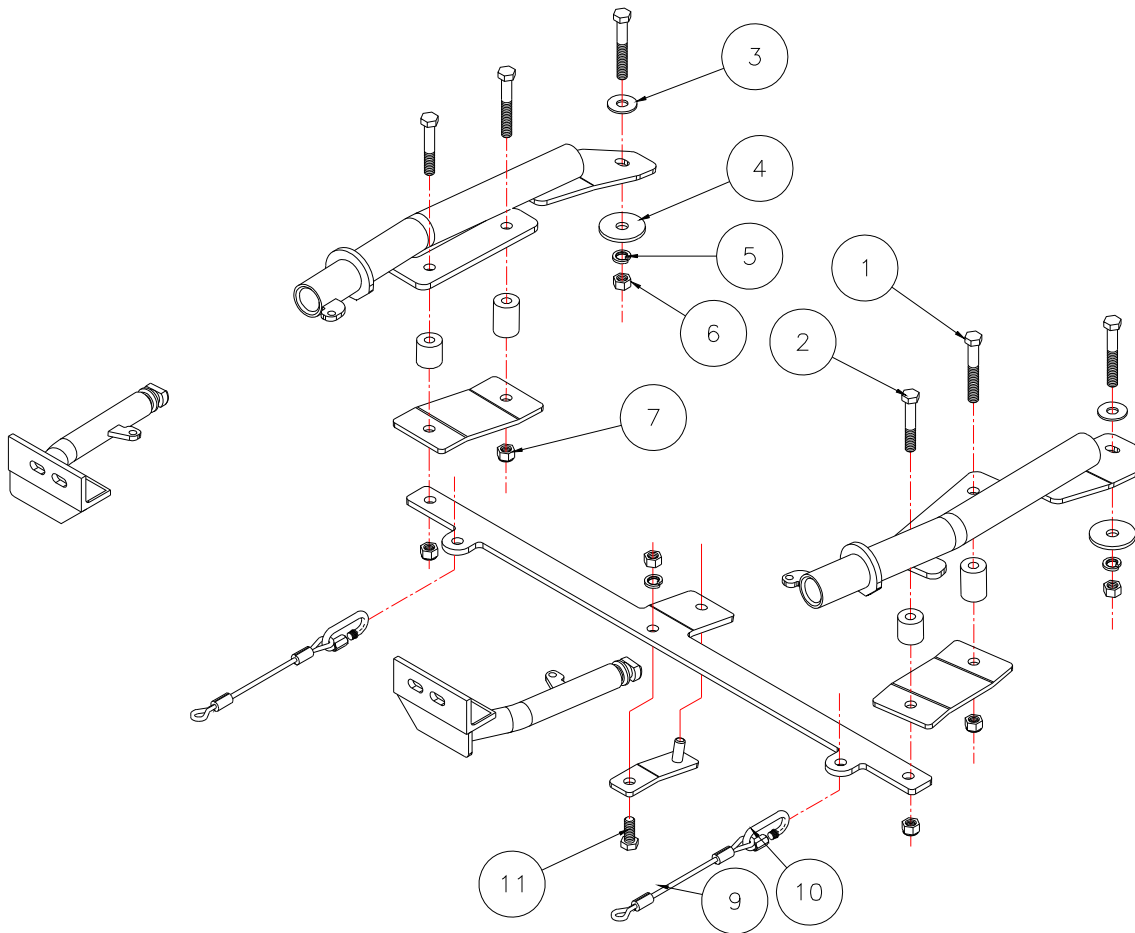

Item	Qty.	Length	Width	Description	Part #
1	4	3 1/2"	1/2"	1/2" x 3 1/2" BOLT	350103-00
2	2	3"	1/2"	1/2" x 3" BOLT	350101-00
3	2		1/2"	FLAT WASHER	350308-00
4	2		2 1/4"	1/2" PLATE WASHER	A-003086
5	3		1/2"	LOCKWASHER	350309-00
6	3		1/2"	NUT	350258-00
7	4		1/2"	NYLOCKNUT	350259-00
9	2	13"		13" SAFETY CABLE	500646-13
10	2			CONNECTOR	200008-00
11	1	1 1/4"	1/2"	BOLT	350094-10
12	3	7"		Zip Tie	300140-00



BASEPLATE KIT INSTALLATION INSTRUCTIONS

KIT# 523114-1

01/26/05
RV

ROADMASTER, Inc. 6110 NE 127th Ave. Vancouver, WA 98682 1-800-669-9690 fax 360-735-9300 www.roadmasterinc.com

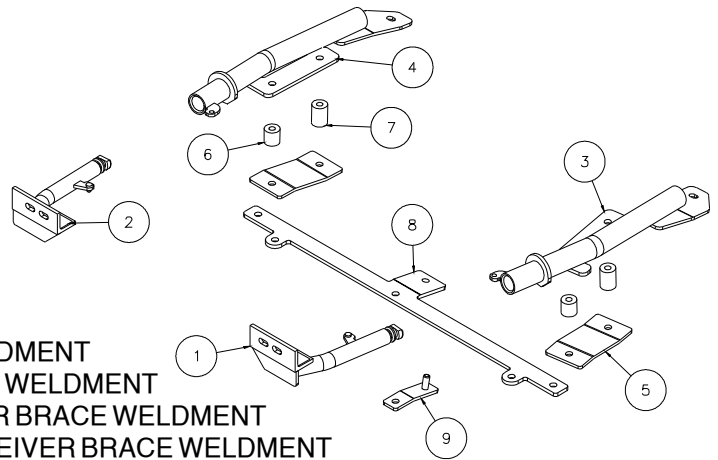

Item	Qty.	Part #	Description
1	1	C-000528	DRIVER SIDE ARM WELDMENT
2	1	C-000529	PASSENGER SIDE ARM WELDMENT
3	1	C-000530	DRIVER SIDE RECEIVER BRACE WELDMENT
4	1	C-000531	PASSENGER SIDE RECEIVER BRACE WELDMENT
5	2	B-000376	LOWER BRACE PLATE
6	2	A-000856	1 1/4" O.D. x 1 1/4" TUBE
7	2	A-000881	1 1/4" O.D. x 1 3/4" TUBE
8	1	B-000714	CROSS BAR
9	1	C-001035	BACKING PLATE WELDMENT

IMPORTANT: All baseplates **must** be assembled with all the bolts left loose for final adjustment and positioning (before tightening) unless otherwise instructed. All bolts **must** be torqued for proper strength. If more than one bolt is used per fastening point, the diagram may only show one. Use flat washers over all slotted holes and lock washers on all fasteners.

WARNING

Failure to heed these warnings or follow the installation instructions may result in a voided warranty, loss of towed vehicle, personal injury or death.

- Do not weld or modify this baseplate or its components. Welding or modification will void the warranty.
- Do not use this document as a basis to design/fabricate a baseplate, as it may not show all parts or structural components.
- We strongly recommend professional installation.
- If the towed vehicle has been in an accident, it must be properly repaired before attaching the baseplate. Do not install the baseplate if any structural frame damage is found.
- The installer must use all bolts and parts supplied. If running changes were made by the vehicle manufacturer after this kit was designed, some bolts or other fasteners may no longer be the correct size. It is the installer's responsibility to verify this kit is securely fastened to the vehicle.
- Use Loctite® Red on all bolts used to secure this baseplate. Torque all bolts to the specifications found at the end of these instructions. Do not over-torque the bolts or failure may occur.
- The installer must inspect the baseplate to ensure adequate clearance, particularly around hoses, air conditioner lines, radiators, etc. or non-warranty failure may result.
- Roadmaster manufactures many styles of baseplates. If your baseplate has removable arms, they must be removed before driving the vehicle, unless the arms can be pinned or padlocked in place. If not secured, the arms could vibrate out.
- Some motorhome chassis have such a tight turning radius that you can damage your motorhome, towed vehicle, tow bar or baseplate while turning sharply. Before getting on the road, test your turning radius in an empty parking lot. Turning too sharply could result in non-warranty damage to your towing system, motorhome and/or towed vehicle.
- Do not back up with the towed vehicle attached or non-warranty damage will occur to your towing system or vehicles.
- The safety cables must connect the towing vehicle to the towed vehicle frame to frame, with the cables crossed, with enough slack for sharp turns. See cable instructions for proper routing. Failure to do so will result in non-warranty damage and/or the loss of the towed vehicle.
- This kit is designed for use with ROADMASTER tow bars and ROADMASTER adapters only. Using this kit with other brands, without an approved ROADMASTER adapter, may result in non-warranty damage or injury.
- Receiver extensions and out-of-level towing situations of 3 inches or more. This can cause the system to swing much higher and lower, causing excessive strain on the tow bar, baseplate and frame. That can cause the towing system to fail, causing property damage, personal injury or even death. If you must use a receiver extension or drop hitch to tow, it will reduce your receiver's weight capacity by 1/3 to avoid damaging your system. Never use more than one extension and/or drop hitch, as this will void your warranty.
- Every 3,000 miles, the owner must inspect all mounting points for cracks or fatigue, and check the fasteners for proper torque, according to the bolt torque requirements chart on the last page of these instructions.
- The owner must follow the vehicle manufacturer's instructions to prepare the vehicle for towing. Failure to do so may cause severe damage to the vehicle.
- This baseplate is only warranted for the original installation. Installing a used baseplate on another vehicle is not recommended and will void the warranty.



BASEPLATE KIT INSTALLATION INSTRUCTIONS

KIT# 523114-1

01/26/05
RV

ROADMASTER, Inc. 6110 NE 127th Ave. Vancouver, WA 98682 1-800-669-9690 fax 360-735-9300 www.roadmasterinc.com

1. This is one of our EZ lock bracket series, which allows the visible front portion of the brackets to be easily removed from the front of the car by rotating the front braces. The bracket kit consists of two main receiver braces, two tubular front braces, a middle alignment brace and a hardware pack. The rear receiver braces mount to the bottom of the sub frame and protrude through the lower grille below the headlights and the bumper. The front tubular braces are inserted into the rear braces and rotated 90 degrees to lock in place. Before starting the installation, lay out the kit components as it is illustrated. This will give you a visual idea of how the components work and also confirm that everything is present and accounted for.



2. **Important:** please use all supplied bolts and parts and read all instructions carefully before beginning this installation. The majority of questions you may have can be answered within the text, and proper installation will ensure safe and secure travel. Now, begin the installation by removing the passenger side splash panel. There are three plastic fasteners on the bottom of the panel and two metal screws near the top in the wheel well area (Fig.A). This will provide access to the subframe mounting area on this side. On the driver's side, there is only one plastic fastener (Fig.B) on the bottom of the splash panel; remove it and let the panel hang loose.



WARNING! INSTALLER MUST READ THE FOLLOWING TO PREVENT NON-WARRANTY DAMAGE.

The following step requires you to reposition two air conditioning lines. Failure to reroute as instructed will allow the tow bar bracket to rub a hole in the lines, resulting in severe non-warranty damage to the air conditioning system.



3. **Warning:** near the lower part of the radiator exists two air conditioning lines that will need to be displaced on both sides of the vehicle. On the passenger side, there is a rubber line that will just need to be pushed back. The line on the driver's side is metal, and will have to be braced with one hand, while pushing up slightly with the other as shown in Fig.C. The areas that need to be cleared are between the lower radiator mounts, and the subframe mount attaching the subframe to the main frame of the vehicle. This void is where the receiver braces will fit on each side. On the driver's side, there is an aluminum canister, which also must be cleared (Fig.D). Check everything for clearance (Fig.E).



BASEPLATE KIT INSTALLATION INSTRUCTIONS

KIT# 523114-1

01/26/05
RV

ROADMASTER, Inc. 6110 NE 127th Ave. Vancouver, WA 98682 1-800-669-9690 fax 360-735-9300 www.roadmasterinc.com



4. Starting with the driver's side, slide the receiver brace through the opening right behind lower subframe, next to the splash panel loosened in step 2. To do this, you must slide the rear part of the receiver brace rearward into the wheel well area just above the drive axle (Fig.F). Once the front portion of the receiver tube is back far enough to clear the subframe, swing over and slide forwards into final position. On the driver's side, there is a small metal canister used in air conditioning (Fig.C), space in this area is limited so be sure to use caution when sliding brace into position. *Note:* to allow for more clearance when sliding the brace forward, gently push upward on bottom of radiator; there is about an inch of play when you do this.

5. The mounting plate on the middle of the receiver brace should lay flat on top of the subframe with two 9/16" holes lined up on either side of the subframe, allowing you to straddle the subframe with the bolts. Use the supplied 1/2" x 3 1/2" bolt for the rear hole, and a 1/2" x 3" bolt in the forward hole, allow these bolts to hang down for now (Fig.G). Locate a 1 3/4" spacer and a formed backing plate in the hardware kit and place them on the rear bolt first (Fig.H), so that the taper is going forward and up, as illustrated. Place a 1 1/4" spacer on the front bolt between the two plates. Now, place the long cross bar on the front bolt underneath the backing plate (Fig.I) and bolt it together using a locknut. Leave it loose for now.



6. With the cross bar in place and using the rear hole as a template drill up through the bottom of the subframe with a 17/32" drill bit. Take the formed backing plate, positioning the stud to the rear hole and bolting through the front into the cross bar with a 1/2" x 1 1/4" bolt, lock washer, and nut (Fig.J,K).

7. Align the rear most mounting hole on the bracket with a hole on top of the subframe and bolt together using a 1/2" x 3 1/2" bolt, flat washer, plate washer, lock washer and nut. Be sure to place the large plate washer underneath the subframe (Fig.L). Leave it loose for now.



8. Repeat steps 3 through 6 on the passenger side (Fig.M).



BASEPLATE KIT INSTALLATION INSTRUCTIONS

KIT# 523114-1

01/26/05
RV

ROADMASTER, Inc. 6110 NE 127th Ave. Vancouver, WA 98682 1-800-669-9690 fax 360-735-9300 www.roadmasterinc.com

9. Use the three supplied zip ties to secure the air tube to the main receiver brace (Fig.N)

10. Install the front braces by inserting them through the lower grill, into the receiver tubes while the clips are horizontal to the ground so the tab on the side of the tube slides into the opening. When the tab has cleared the grill opening, rotate arm back 90 degrees as shown in (Fig.O). Push in and twist down to lock into place.

11. Once they are rotated into place and parallel to the ground, measure across the front braces and adjust until outer mounting holes are 30" on center. Mount the tow bar on the front braces according to the tow bar manufacturer's instructions and center on the vehicle, then tighten all mounting bolts to the torque specifications below.

12. Reverse step 2 and replace the fasteners on both sides that were removed from the lower splash shields. You should be able to stretch the splash shield over the mounting bolt; if not, mark the panel where contact is made with the mounting bolts, and cut clearance holes.

13. Mount the tow bar according to the tow bar manufacturer's instructions. Install the 13" safety cables to the holes on the center brace installed in step 6 with the quick links provided. Attach the other end to the tow vehicle's safety cables and the tow bar.

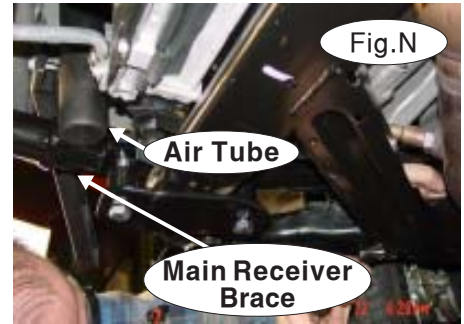

BOLT TORQUE REQUIREMENTS

Note: The torque values represented below are intended as general guidelines. Torque requirements for specific applications may vary. Roadmaster does not warrant this information to be accurate for all applications and disclaims all liability for any claims or damages which may result from its use.

STANDARD BOLTS			METRIC BOLTS			METRIC BOLTS		
Thread Size	Grade	Torque	Thread Size	Grade	Plated/Unplated	Thread Size	Grade	Plated/Unplated
5/16	5	13 ft./lb.	8mm-1.0	8.8	20 ft./lb. 18 ft./lb.	12mm-1.25	8.8	70 ft./lb. 65 ft./lb.
3/8	5	23 ft./lb.	8mm-1.25	8.8	19 ft./lb. 18 ft./lb.	12mm-1.5	8.8	66 ft./lb. 61 ft./lb.
7/16	5	37 ft./lb.	10mm-1.25	8.8	38 ft./lb. 36 ft./lb.	12mm-1.75	8.8	65 ft./lb. 60 ft./lb.
1/2	5	56 ft./lb.	10mm-1.5	8.8	37 ft./lb. 35 ft./lb.	14mm-2.0	8.8	104 ft./lb. 97 ft./lb.
5/8	5	150 ft./lb.						

All illustrations and specifications contained herein are based on the latest information available at the time of publication approval. ROADMASTER, INC. reserves the right to make changes at any time without notice in material, specification and models or to discontinue models.