



BASEPLATE KIT INSTALLATION INSTRUCTIONS

KIT# 523159-1

06/03/13
KS

ROADMASTER, Inc. 6110 NE 127th Ave. Vancouver, WA 98682 360-896-0407 fax 360-735-9300 www.roadmasterinc.com

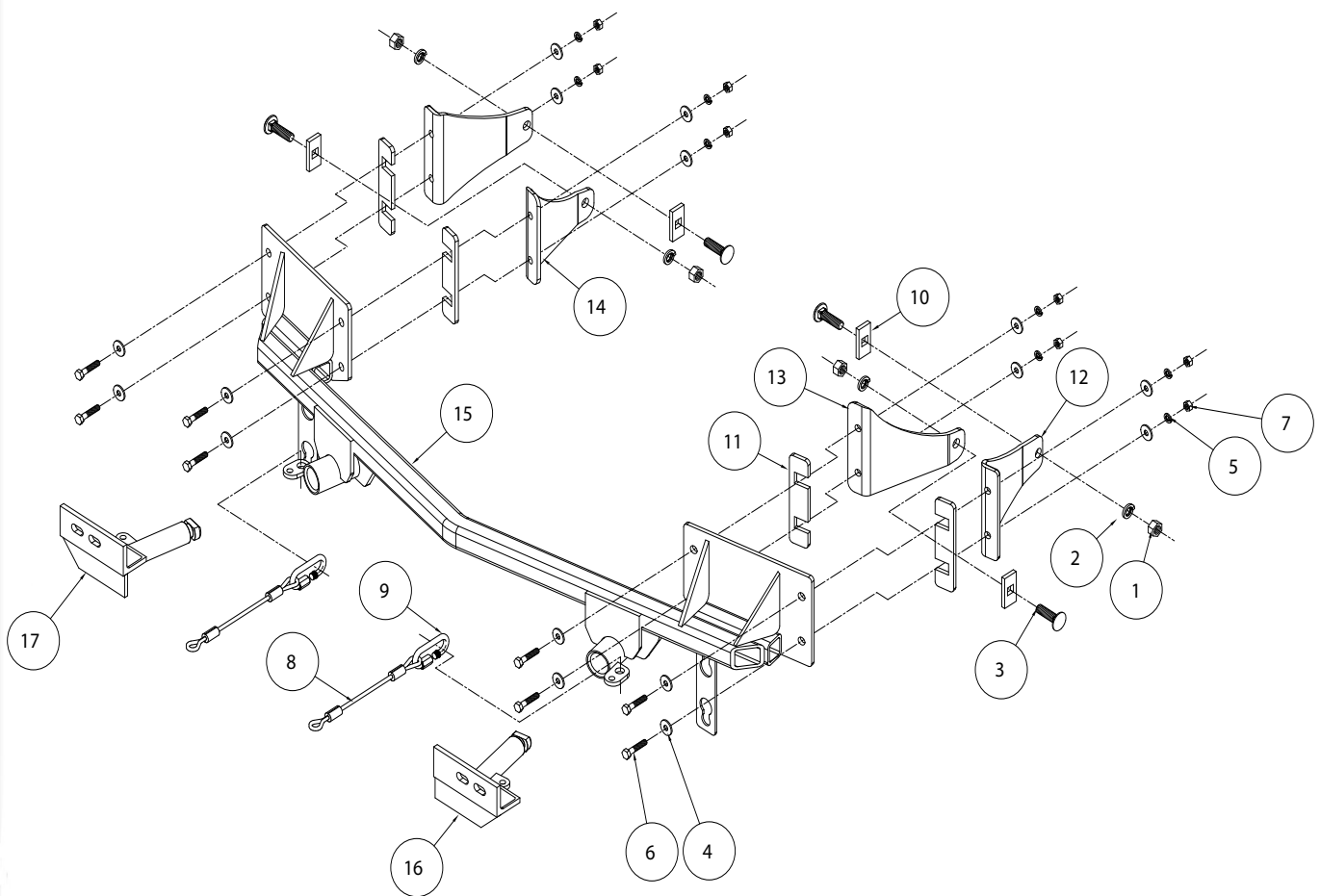

ITEM	QTY	NAME	MATERIAL
1.....	4	1/2" HEX NUT	350258-00
2.....	4	1/2" LOCK WASHER	350309-00
3.....	4	1/2" x 1 3/4" CARRIAGE BOLT	350363-00
4.....	16	8mm FENDER WASHER	355702-00
5.....	8	8mm LOCK WASHER	355705-00
6.....	8	8mm x 1.25 x 40 mm BOLT	356003-50
7.....	8	8mm HEX NUT	356208-00
8.....	2	SAFETY CABLE 8"	650646-08
9.....	2	QUICK LINK	200008-00
10.....	4	1/4" x 1" x 2" SQUARE HOLE BACKING PLATE	A-000040
11.....	4	1/4" x 1 3/8" x 5 7/8" SPACER PLATE	A-002906
12.....	2	OUTER BRACE PLATE	B-001264
13.....	1	DRIVER SIDE INNER BRACE PLATE	B-001265
14.....	1	PASSENGER SIDE INNER BRACE PLATE	B-001266
15.....	1	MAIN RECEIVER	C-001846
16.....	1	DRIVER SIDE ARM	C-001847
17.....	1	PASSENGER SIDE ARM	C-001848



BASEPLATE KIT INSTALLATION INSTRUCTIONS

KIT# 523159-1

06/03/13
KS

ROADMASTER, Inc. 6110 NE 127th Ave. Vancouver, WA 98682 360-896-0407 fax 360-735-9300 www.roadmasterinc.com

This is one of our EZ2 series brackets, which allows the visible front portion of the bracket to be easily removed from the front of the vehicle (Fig.A and Fig.B). The bracket consists of a main receiver brace, two outer support braces, two inner support braces, two removable front braces and a hardware pack.

The main receiver brace mounts to the frame rails. The support braces are attached to the main receiver brace. The removable front braces install in the main receiver brace.

Before starting the installation, lay out the kit components in order, as they will be used. This will give you a visual idea of how the components work, and will also confirm that everything is present and accounted for.



IMPORTANT: All baseplates **must** be assembled with all the bolts left loose for final adjustment and positioning (before tightening) unless otherwise instructed. All bolts **must** be torqued for proper strength. If more than one bolt is used per fastening point, the diagram may only show one. Use flat washers over all slotted holes and lock washers on all fasteners.

WARNING

Failure to heed these warnings or follow the installation instructions may result in a voided warranty, loss of towed vehicle, personal injury or death.

- Do not weld or modify this baseplate or its components. Welding or modification will void the warranty.
- Do not use this document as a basis to design/fabricate a baseplate, as it may not show all parts or structural components.
- We strongly recommend professional installation.
- If the towed vehicle has been in an accident, it must be properly repaired before attaching the baseplate. Do not install the baseplate if any structural frame damage is found.
- The installer must use all bolts and parts supplied. If running changes were made by the vehicle manufacturer after this kit was designed, some bolts or other fasteners may no longer be the correct size. It is the installer's responsibility to verify this kit is securely fastened to the vehicle.
- Use Loctite® Red on all bolts used to secure this baseplate. Torque all bolts to the specifications found at the end of these instructions. Do not over-torque the bolts or failure may occur.
- The installer must inspect the baseplate to ensure adequate clearance, particularly around hoses, air conditioner lines, radiators, etc. or non-warranty failure may result.
- Roadmaster manufactures many styles of baseplates. If your baseplate has removable arms, they must be removed before driving the vehicle, unless the arms can be pinned or padlocked in place. If not secured, the arms could vibrate out.
- Some motorhome chassis have such a tight turning radius that you can damage your motorhome, towed vehicle, tow bar or baseplate while turning sharply. Before getting on the road, test your turning radius in an empty parking lot. Turning too sharply could result in non-warranty damage to your towing system, motorhome and/or towed vehicle.
- Do not back up with the towed vehicle attached or non-warranty damage will occur to your towing system or vehicles.
- The safety cables must connect the towing vehicle to the towed vehicle frame to frame, with the cables crossed, with enough slack for sharp turns. See cable instructions for proper routing. Failure to do so will result in non-warranty damage and/or the loss of the towed vehicle.
- This kit is designed for use with ROADMASTER tow bars and ROADMASTER adapters only. Using this kit with other brands, without an approved ROADMASTER adapter, may result in non-warranty damage or injury.
- Receiver extensions and out-of-level towing situations of 3 inches or more. This can cause the system to swing much higher and lower, causing excessive strain on the tow bar, baseplate and frame. That can cause the towing system to fail, causing property damage, personal injury or even death. If you must use a receiver extension or drop hitch to tow, it will reduce your receiver's weight capacity by 1/3 to avoid damaging your system. Never use more than one extension and/or drop hitch, as this will void your warranty.
- Every 3,000 miles, the owner must inspect all mounting points for cracks or fatigue, and check the fasteners for proper torque, according to the bolt torque requirements chart on the last page of these instructions.
- The owner must follow the vehicle manufacturer's instructions to prepare the vehicle for towing. Failure to do so may cause severe damage to the vehicle.
- This baseplate is only warranted for the original installation. Installing a used baseplate on another vehicle is not recommended and will void the warranty.



BASEPLATE KIT INSTALLATION INSTRUCTIONS

KIT# 523159-1

06/03/13
KS

ROADMASTER, Inc. 6110 NE 127th Ave. Vancouver, WA 98682 360-896-0407 fax 360-735-9300 www.roadmasterinc.com

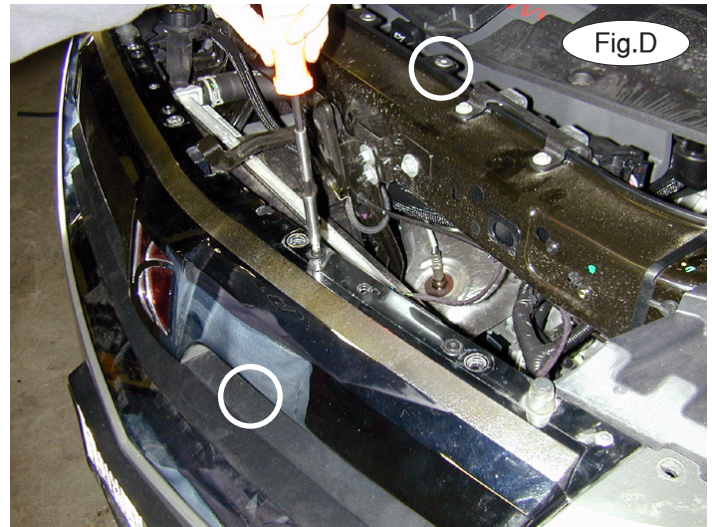
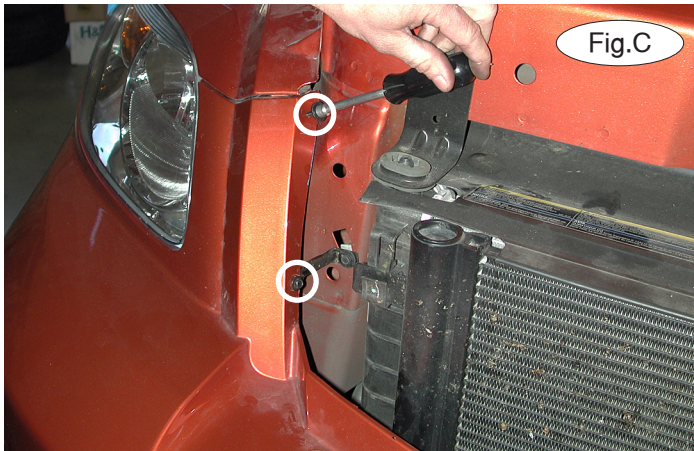

1. **Important:** please use all supplied bolts and parts and read all instructions carefully before beginning this installation. The majority of questions you may have can be answered within the text, and proper installation will ensure safe and secure travel. Now, begin the installation. On each side, remove two 7mm head screws located on the inside edge of the engine compartment (Fig.C).

2. On each side, remove three plastic fasteners and one 7mm head screw attaching the fender liner to the fascia (Fig.D).

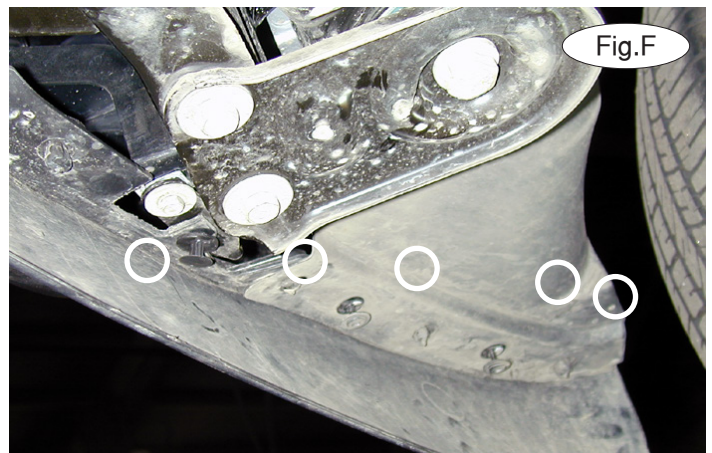

3. On each side, remove two plastic fasteners and one 7mm head screw attaching the bottom of the fender liner to the splash shield (Fig.E).

4. Across the bottom of the fascia, remove ten 7mm head screws attaching the air deflector to the bottom of the fascia. The driver's side screws are shown in Figure F.

Then, remove the air deflector.



BASEPLATE KIT INSTALLATION INSTRUCTIONS

KIT# 523159-1

06/03/13
KS

ROADMASTER, Inc. 6110 NE 127th Ave. Vancouver, WA 98682 360-896-0407 fax 360-735-9300 www.roadmasterinc.com

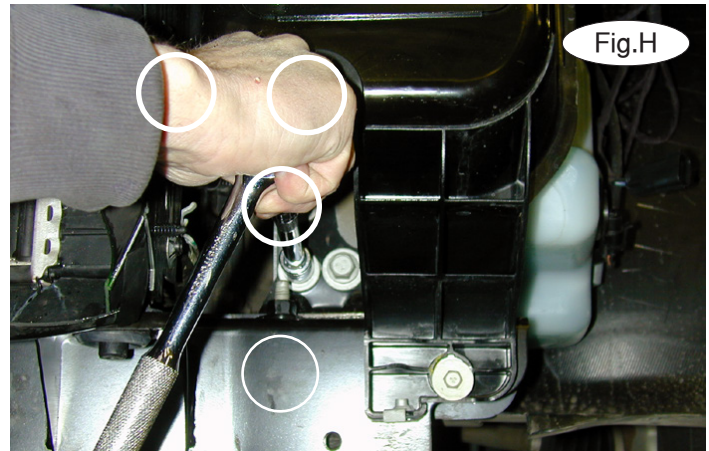

5. At each side, reach inside the fender liner and unplug the side marker lights. Unplug the fog lights, if the vehicle is so equipped.

6. At each side, pull out and forward on the edge of the fascia to release the fascia from the lock strips (Fig.G).

7. Remove the inner cooler mounting brackets and backing plates by removing four 10mm head bolts from each side (Fig.H).

Note: the inner cooler mounting brackets and mounting plates will not be replaced. Retain the brackets and plates so that they can be replaced if the bracket is ever removed.

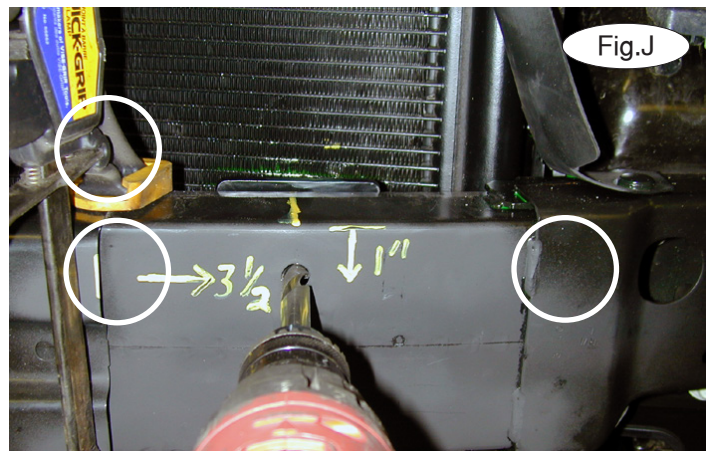
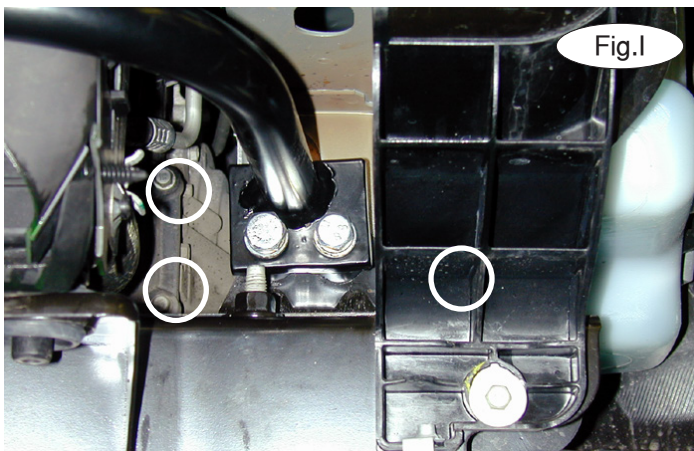

8. On each side, remove three 13mm head bolts attaching the bumper core to the end of the frame rail, and remove the bumper core.

Note: the bumper core will not be replaced. Retain the bumper core so that it can be replaced if the bracket is ever removed.

9. Position the main brace over the ends of the frame rail, so that the three pre-drilled holes at each end of the main brace align to the three holes at the end of the frame rail.

10. At each side, bolt the main brace into place with three of the supplied 8mm x 1.25 x 40mm bolts and fender washers. Torque the bolts to 19 ft./lbs.

Note: do not use the supplied lock washers. They will be used on the other side of the main brace.



BASEPLATE KIT INSTALLATION INSTRUCTIONS

KIT# 523159-1

06/03/13
KS

ROADMASTER, Inc. 6110 NE 127th Ave. Vancouver, WA 98682 360-896-0407 fax 360-735-9300 www.roadmasterinc.com

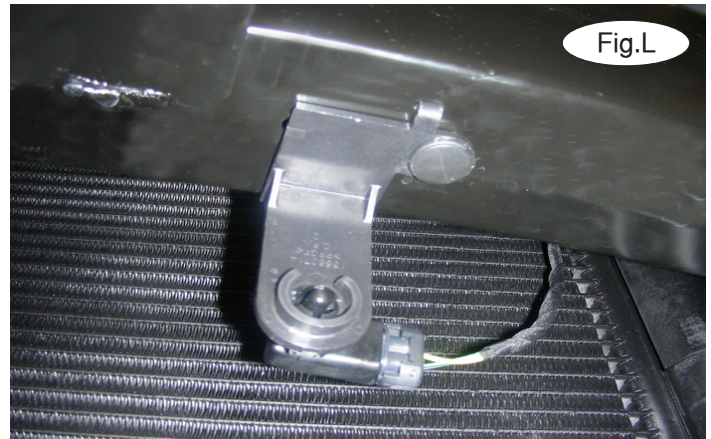
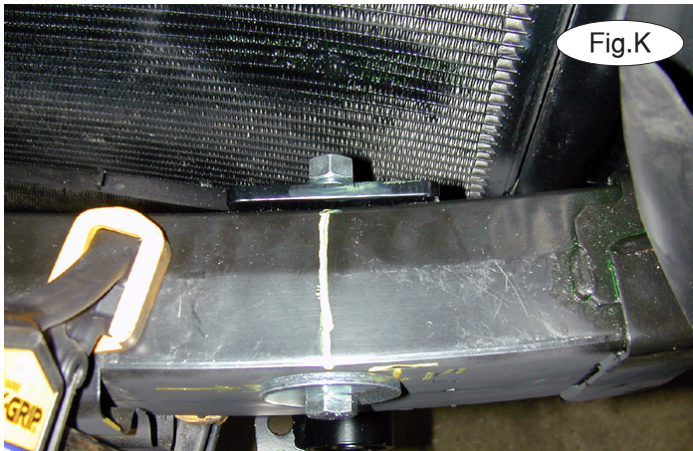

11. On each side, position one of the outer support braces over the two bolts you attached in the previous step (Fig.K).
At each support brace, place two of the supplied 8mm fender washers, lock washers and nuts over the bolts, to hold the outer support braces in position.
12. At each side, fishwire one of the provided $\frac{1}{2}$ " x $1\frac{1}{2}$ " carriage bolts and a 1" x 2" square-holed backing plate through the existing square hole at the bottom of the frame rail and the rear pre-drilled hole in the outer support braces (Fig.L).
At each side, thread one of the supplied $\frac{1}{2}$ " lock washers and nuts over the carriage bolt, to hold the backing plate in position.

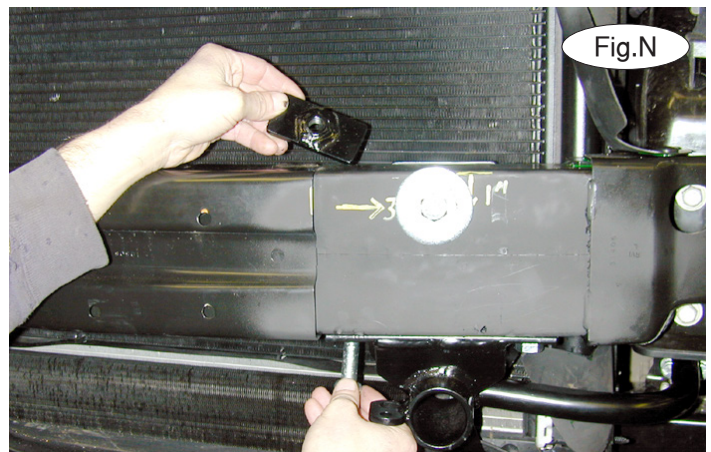
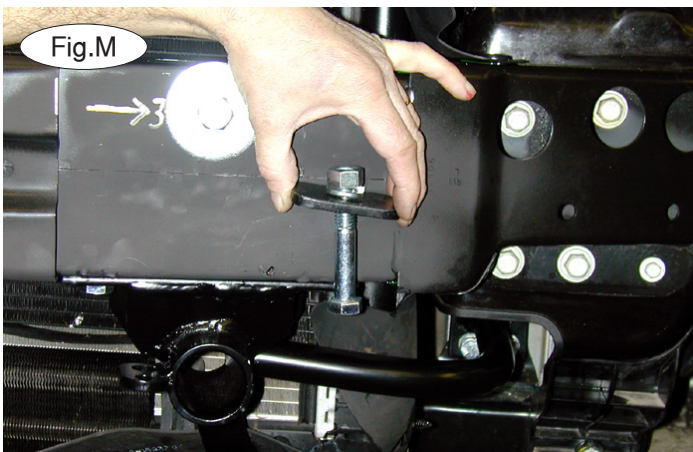

13. At each side, using the main receiver brace as a template, drill a $\frac{3}{8}$ " hole through the frame rail (Fig.M).
14. Then, position one of the supplied 8mm x 1.25 x 40mm bolts, with a fender washer, through the main receiver brace and the end of the frame rail.
15. At each side, place one of the inside support braces over the bolts. Thread two supplied 8mm fender washers, lock washers and nuts over the bolts, to hold the inside support braces in position (Fig.N).



BASEPLATE KIT INSTALLATION INSTRUCTIONS

KIT# 523159-1

06/03/13
KS

ROADMASTER, Inc. 6110 NE 127th Ave. Vancouver, WA 98682 360-896-0407 fax 360-735-9300 www.roadmasterinc.com

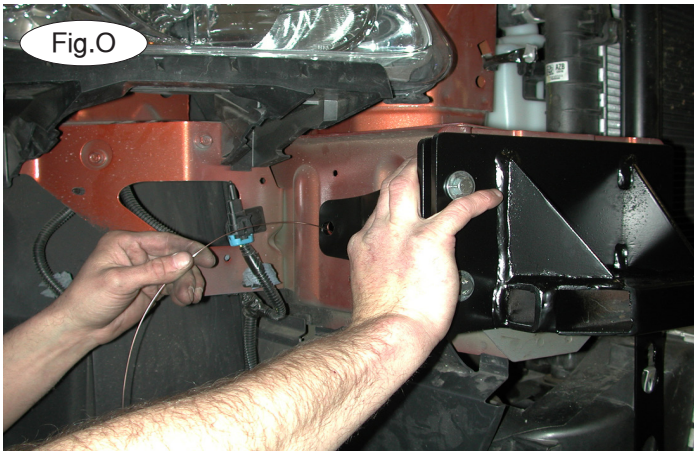

16. At each side, fishwire a $\frac{1}{2}$ " x $1\frac{1}{2}$ " carriage bolt and 1" x 2" square-holed backing plate through the same hole in the frame rail, and through the pre-drilled holes at the rear of the inner support braces (Fig.O). Thread two of the supplied $\frac{1}{2}$ " lock washers and nuts over the carriage bolts, to hold the backing plate in position (Fig.P).

17. At each side, insert two spacer plates (Fig.Q) between the end of the frame rail and the inner and outer support braces. Slide the spacer plates in until they can go no further.

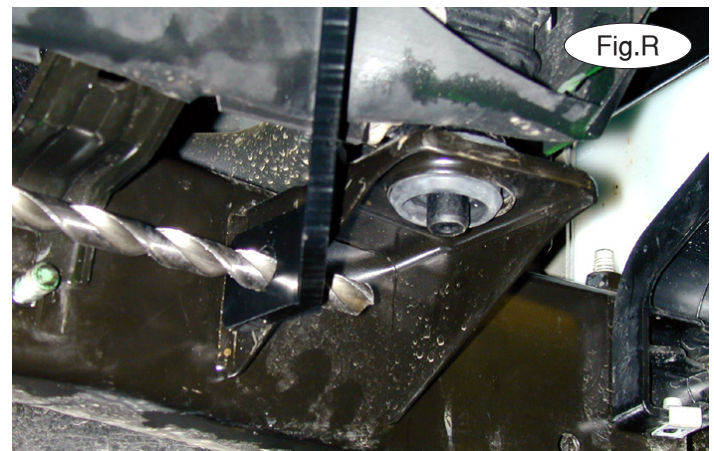
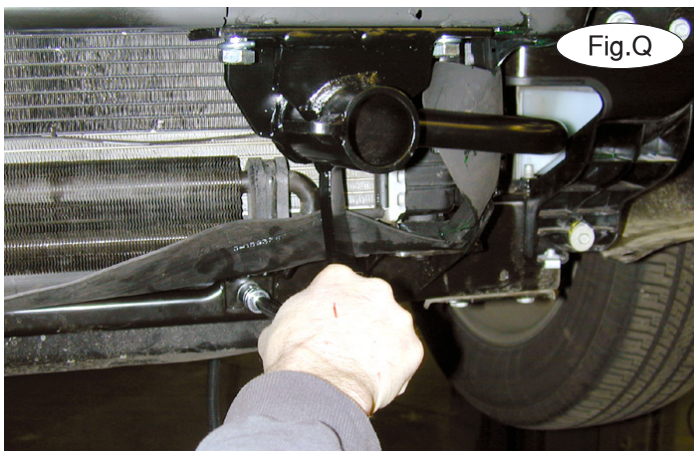

18. Torque the inner and outer support brace nuts (Fig.R) to the specifications listed at the bottom of these instructions, starting with the forward 8mm nuts, then the back $\frac{1}{2}$ " nuts.

19. At each side, remove the two rubber grommets from the factory inner cooler mounts and place them on the inner cooler mounts on the main brace (Fig.S).

20. Remount the inner cooler to the main brace, using two of the 10mm head bolts (on each side) which you removed in step 7.





BASEPLATE KIT INSTALLATION INSTRUCTIONS

KIT# 523159-1

06/03/13
KS

ROADMASTER, Inc. 6110 NE 127th Ave. Vancouver, WA 98682 360-896-0407 fax 360-735-9300 www.roadmasterinc.com

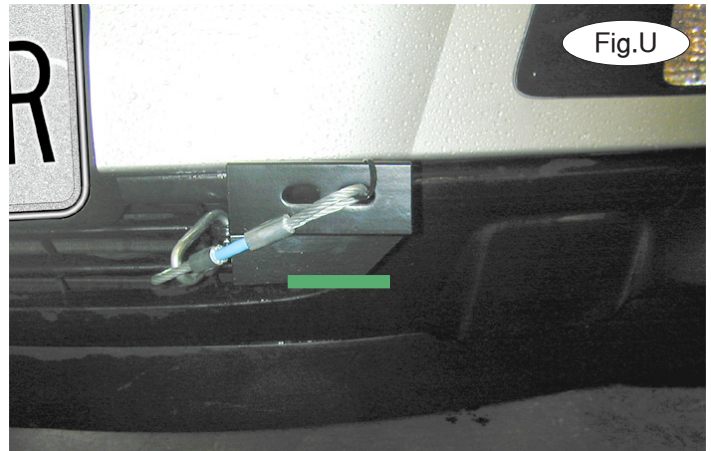
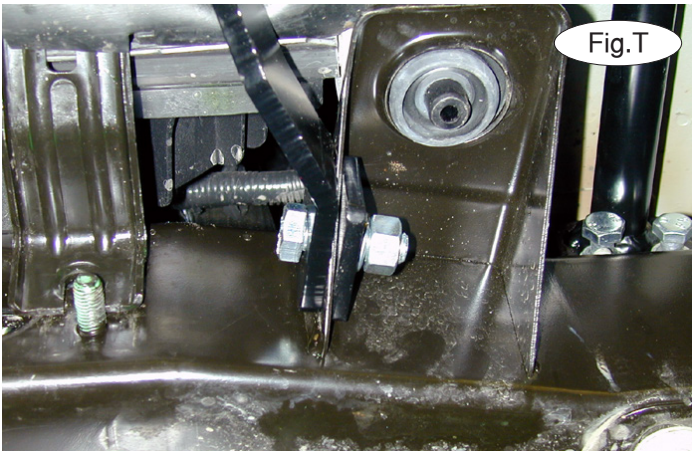

21. Remove the foam core from the fascia by removing two plastic screws (Fig.T), and trim off the two plastic tabs which held the foam core. Use the green marker line in Figure U as a reference for trimming. *Note:* the foam core will not be replaced. Retain the foam core so that it can be replaced if the bracket is ever removed.

22. The grille on the fascia must be trimmed, in order to accommodate the two removable front bracket arms. Hold the fascia in place, over the main brace, and mark for trimming. Use the green marker lines in Figure V as a reference for trimming.



- 23. Reinstall the fascia and air deflector by reversing steps 1 through 6.
- 24. Insert the removable front bracket arms into the front receiver braces, and twist each one 90 degrees to lock.
- 25. Attach the 8" safety cables with the cable connectors (Q-Links) to the front of the receiver braces (Fig.W).
- 26. Attach the ends of the safety cables to the tow vehicle's safety cables.
- 27. Install the tow bar to the mounting bracket according to the manufacturer's instructions.

BOLT TORQUE REQUIREMENTS

Note: The torque values represented below are intended as general guidelines. Torque requirements for specific applications may vary. Roadmaster does not warrant this information to be accurate for all applications and disclaims all liability for any claims or damages which may result from its use.

STANDARD BOLTS

Thread Size	Grade	Torque
5/16.....	5.....	13 ft./lb.
3/8.....	5.....	23 ft./lb.
7/16.....	5.....	37 ft./lb.
1/2.....	5.....	56 ft./lb.
5/8.....	5.....	150 ft./lb.

METRIC BOLTS

Thread Size	Grade	Plated / Unplated
8mm-1.0	8.8	20 ft./lb. 18 ft./lb.
8mm-1.25	8.8	19 ft./lb. 18 ft./lb.
10mm-1.25	8.8	38 ft./lb. 36 ft./lb.
10mm-1.5	8.8	37 ft./lb. 35 ft./lb.

METRIC BOLTS

Thread Size	Grade	Plated / Unplated
12mm-1.25	8.8	70 ft./lb. 65 ft./lb.
12mm-1.5	8.8	66 ft./lb. 61 ft./lb.
12mm-1.75	8.8	65 ft./lb. 60 ft./lb.
14mm-2.0	8.8	104 ft./lb. 97 ft./lb.

All illustrations and specifications contained herein are based on the latest information available at the time of publication approval. ROADMASTER, INC. reserves the right to make changes at any time without notice in material, specification and models or to discontinue models.