



BASEPLATE KIT INSTALLATION INSTRUCTIONS

KIT# 523171-1

02/20/13
KS

ROADMASTER, Inc. 6110 NE 127th Ave. Vancouver, WA 98682 360-896-0407 fax 360-735-9300 www.roadmasterinc.com

Special tools required
A 2½" hole saw

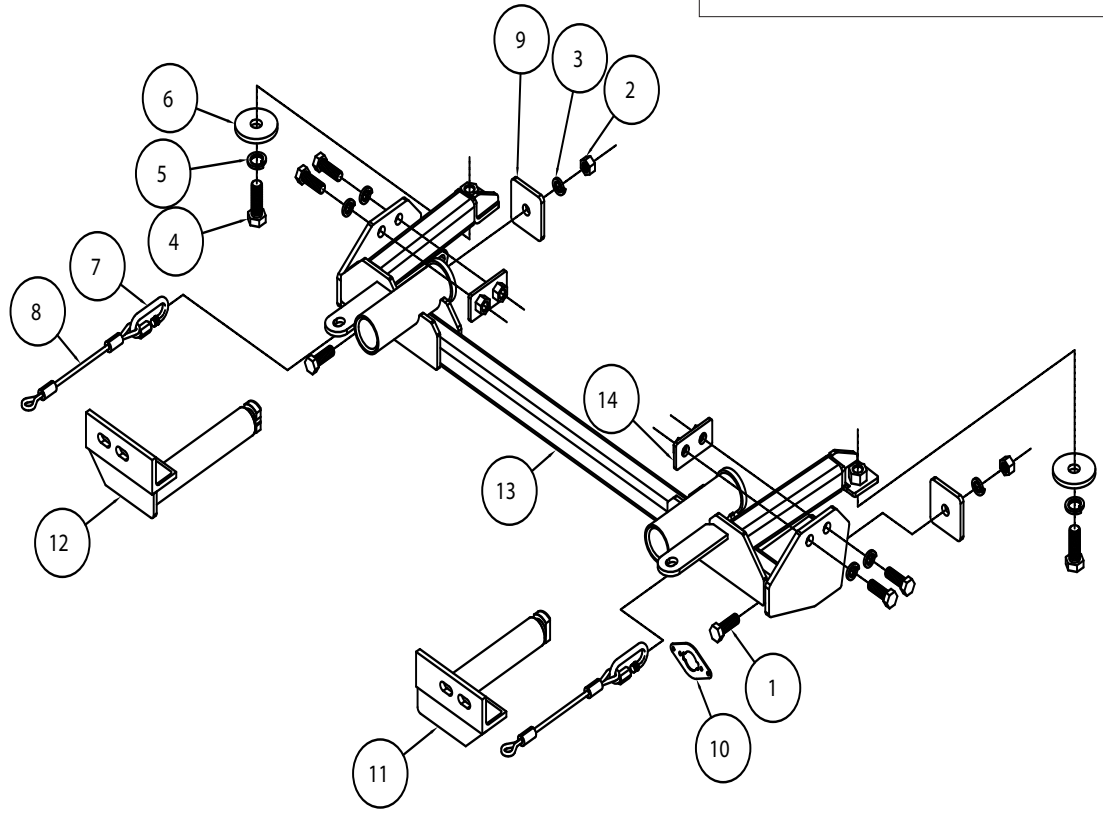

ITEM	QTY	NAME	MATERIAL
1.....	6.....	1/2" x 1 1/2" BOLT.....	350095-00
2.....	2.....	1/2" HEX NUT.....	350258-00
3.....	6.....	1/2" LOCKWASHER.....	350309-00
4.....	2.....	5/8" x 1 3/4" BOLT.....	350149-00
5.....	2.....	5/8" LOCKWASHER.....	350734-00
6.....	2.....	5/8" PLATE WASHER.....	350352-00
7.....	2.....	QUICK LINK.....	200008-00
8.....	2.....	8" SAFETY CABLES.....	650648-8
9.....	2.....	1/4" x 2 1/2" x 2 1/2" BACKING PLATE.....	A-002221
10.....	1.....	WIRE PLUG MOUNTING PLATE.....	A-003801
11.....	1.....	DRIVER SIDE ARM.....	C-002326
12.....	1.....	PASSENGER SIDE ARM.....	C-002327
13.....	1.....	MAIN RECEIVER.....	C-002328
14.....	2.....	THREADED BACKING PLATE.....	C-002329



BASEPLATE KIT INSTALLATION INSTRUCTIONS

KIT# 523171-1

02/20/13
KS

ROADMASTER, Inc. 6110 NE 127th Ave. Vancouver, WA 98682 360-896-0407 fax 360-735-9300 www.roadmasterinc.com

This is one of our EZ2 series brackets, which allows the visible front portion of the bracket to be easily removed from the front of the vehicle (Fig.A and Fig.B). The bracket consists of a main receiver brace, two removable front braces, and a hardware pack.

The main receiver brace mounts to the frame rails and the bumper core. The removable front braces install in the main receiver brace.

Before starting the installation, lay out the kit components in order, as they will be used. This will give you a visual idea of how the components work, and will also confirm that everything is present and accounted for.



IMPORTANT: All baseplates **must** be assembled with all the bolts left loose for final adjustment and positioning (before tightening) unless otherwise instructed. All bolts **must** be torqued for proper strength. If more than one bolt is used per fastening point, the diagram may only show one. Use flat washers over all slotted holes and lock washers on all fasteners.

WARNING

Failure to heed these warnings or follow the installation instructions may result in a voided warranty, loss of towed vehicle, personal injury or death.

- Do not weld or modify this baseplate or its components. Welding or modification will void the warranty.
- Do not use this document as a basis to design/fabricate a baseplate, as it may not show all parts or structural components.
- We strongly recommend professional installation.
- If the towed vehicle has been in an accident, it must be properly repaired before attaching the baseplate. Do not install the baseplate if any structural frame damage is found.
- The installer must use all bolts and parts supplied. If running changes were made by the vehicle manufacturer after this kit was designed, some bolts or other fasteners may no longer be the correct size. It is the installer's responsibility to verify this kit is securely fastened to the vehicle.
- Use Loctite® Red on all bolts used to secure this baseplate. Torque all bolts to the specifications found at the end of these instructions. Do not over-torque the bolts or failure may occur.
- The installer must inspect the baseplate to ensure adequate clearance, particularly around hoses, air conditioner lines, radiators, etc. or non-warranty failure may result.
- Roadmaster manufactures many styles of baseplates. If your baseplate has removable arms, they must be removed before driving the vehicle, unless the arms can be pinned or padlocked in place. If not secured, the arms could vibrate out.
- Some motorhome chassis have such a tight turning radius that you can damage your motorhome, towed vehicle, tow bar or baseplate while turning sharply. Before getting on the road, test your turning radius in an empty parking lot. Turning too sharply could result in non-warranty damage to your towing system, motorhome and/or towed vehicle.
- Do not back up with the towed vehicle attached or non-warranty damage will occur to your towing system or vehicles.
- The safety cables must connect the towing vehicle to the towed vehicle frame to frame, with the cables crossed, with enough slack for sharp turns. See cable instructions for proper routing. Failure to do so will result in non-warranty damage and/or the loss of the towed vehicle.
- This kit is designed for use with ROADMASTER tow bars and ROADMASTER adapters only. Using this kit with other brands, without an approved ROADMASTER adapter, may result in non-warranty damage or injury.
- Receiver extensions and out-of-level towing situations of 3 inches or more. This can cause the system to swing much higher and lower, causing excessive strain on the tow bar, baseplate and frame. That can cause the towing system to fail, causing property damage, personal injury or even death. If you must use a receiver extension or drop hitch to tow, it will reduce your receiver's weight capacity by 1/3 to avoid damaging your system. Never use more than one extension and/or drop hitch, as this will void your warranty.
- Every 3,000 miles, the owner must inspect all mounting points for cracks or fatigue, and check the fasteners for proper torque, according to the bolt torque requirements chart on the last page of these instructions.
- The owner must follow the vehicle manufacturer's instructions to prepare the vehicle for towing. Failure to do so may cause severe damage to the vehicle.
- This baseplate is only warranted for the original installation. Installing a used baseplate on another vehicle is not recommended and will void the warranty.



BASEPLATE KIT INSTALLATION INSTRUCTIONS

KIT# 523171-1

02/20/13
KS

ROADMASTER, Inc. 6110 NE 127th Ave. Vancouver, WA 98682 360-896-0407 fax 360-735-9300 www.roadmasterinc.com



1. **Important:** please use all supplied bolts and parts and read all instructions carefully before beginning this installation. The majority of questions you may have can be answered within the text, and proper installation will ensure safe and secure travel. Now, begin the installation. Remove six 10mm (head) bolts attaching the top of the fascia to the core support (Fig.C).

2. On each side remove two 7mm (head) screws and three plastic fasteners attaching the fender liner to the fascia (Fig.D).



3. On each side, loosen two 10mm (head) bolts behind the corner of the fascia, attaching the locking strip to the fender. Their approximate locations are shown in Figure E.

4. On each side, remove one 10mm (head) bolt attaching the bottom of the fascia to the frame reinforcement (Fig.F).

5. Pull out and forward on the corners of the fascia to remove it (Fig.G).





BASEPLATE KIT INSTALLATION INSTRUCTIONS

KIT# 523171-1

02/20/13
KS

ROADMASTER, Inc. 6110 NE 127th Ave. Vancouver, WA 98682 360-896-0407 fax 360-735-9300 www.roadmasterinc.com



6. On each side, place the main receiver brace through the opening in the frame rail, aligning it with the existing holes in the bottom and sides of the frame rail. Now, place one of the supplied $5/8"$ lock washers and plate washers over a $5/8"$ x $1\frac{3}{4}"$ bolt, and bolt up through the existing hole in the bottom of the frame rail and into the weld nut and rear mounting point of the main receiver brace (Fig.H).

7. On each side, using one of the supplied $\frac{1}{4}"$ x $2\frac{1}{2}"$ x $2\frac{1}{2}"$ backing plate over the back side of the frame reinforcement. Mark the center for drilling (Fig.I). On each side, use a $9/16"$ drill bit to drill through the frame reinforcement (Fig.J).



8. On each side, bolt through the lower mounting point and frame reinforcement and backing plate using one of the supplied $\frac{1}{2}"$ x $3\frac{1}{2}"$ bolts. Finish with a $\frac{1}{2}"$ lock washer and nut (Fig.K).

9. On the driver's side only, using the existing hole in the main receiver brace as a template, drill a $\frac{1}{2}"$ hole through the side mounting point (Fig.L).

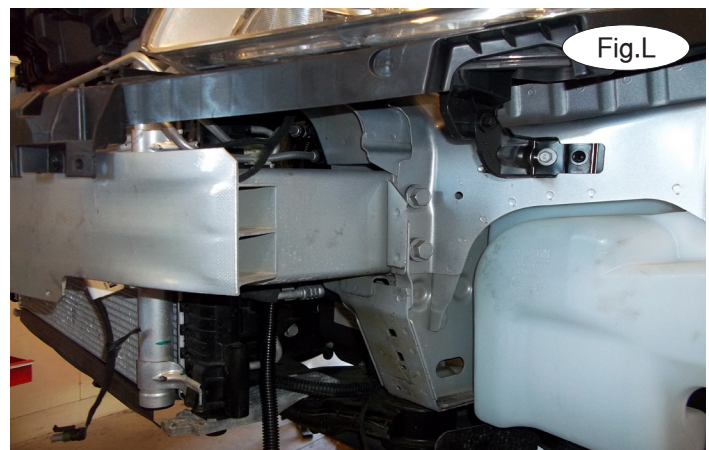



BASEPLATE KIT INSTALLATION INSTRUCTIONS

KIT# 523171-1

02/20/13
KS

ROADMASTER, Inc. 6110 NE 127th Ave. Vancouver, WA 98682 360-896-0407 fax 360-735-9300 www.roadmasterinc.com

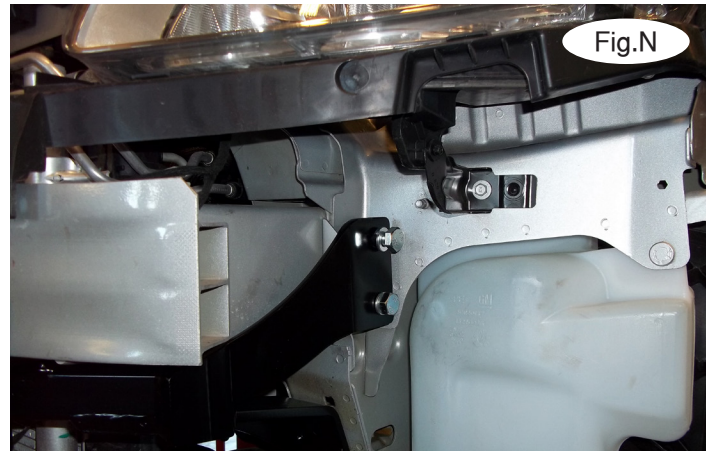

10. On each side, place one of the supplied 3/16" x 1 1/2" x 3" backing plates inside the frame rail, aligning the holes with the two existing holes in the frame rail. Using the supplied 1/2" x 1 3/4" bolts and lock washers, bolt through the outside of the main receiver brace, frame rail and into the backing plate (Fig.M).

11. Tighten all bolts to the bolt torque requirements found at the end of these instructions.



12. Place the template from the end of these instructions over the outermost grille inserts. Mark the center and outermost point (Fig.N) and then trim using a 2 1/2" hole saw (Fig.O).

13. Reinstall the fascia, reversing steps 1 through 5.

14. Insert the removable front bracket arms into the front receiver braces, and twist each one 90 degrees to lock.

15. Attach the 8" safety cables with the cable connectors (Q-Links) to the front of the receiver braces (Fig.P).

16. Attach the ends of the safety cables to the tow vehicle's safety cables.

17. Install the tow bar to the mounting bracket according to the manufacturer's instructions.



BASEPLATE KIT INSTALLATION INSTRUCTIONS

KIT# 523171-1

02/20/13
KS

ROADMASTER, Inc. 6110 NE 127th Ave. Vancouver, WA 98682 360-896-0407 fax 360-735-9300 www.roadmasterinc.com

Three options for attaching the wiring plug to the main receiver brace

For six-wire plugs: use the two supplied 3/4" self-tapping screws to attach the electrical plug directly to the rods on the front of the main receiver brace.

For four-wire round plugs: attach to the plug mounting plate and then use the two supplied 3/4" self-tapping screws to attach the mounting plate to the rods on the front of the main receiver brace.

For four-wire flat plugs: place the plug through the mounting plug plate, and then secure it using the supplied zip tie on the front of the plug (Fig.Q). Use the two supplied 3/4" self-tapping screws to attach the mounting plate to the rods on the front of the main receiver brace.



BOLT TORQUE REQUIREMENTS

Note: The torque values represented below are intended as general guidelines. Torque requirements for specific applications may vary. Roadmaster does not warrant this information to be accurate for all applications and disclaims all liability for any claims or damages which may result from its use.

STANDARD BOLTS

Thread Size	Grade	Torque
5/16.....	5.....	13 ft./lb.
3/8.....	5.....	23 ft./lb.
7/16.....	5.....	37 ft./lb.
1/2.....	5.....	56 ft./lb.
5/8.....	5.....	150 ft./lb.

METRIC BOLTS

Thread Size	Grade	Plated / Unplated
8mm-1.0.....	8.8.....	20 ft./lb. 18 ft./lb.
8mm-1.25.....	8.8.....	19 ft./lb. 18 ft./lb.
10mm-1.25.....	8.8.....	38 ft./lb. 36 ft./lb.
10mm-1.5.....	8.8.....	37 ft./lb. 35 ft./lb.

METRIC BOLTS

Thread Size	Grade	Plated / Unplated
12mm-1.25.....	8.8.....	70 ft./lb. 65 ft./lb.
12mm-1.5.....	8.8.....	66 ft./lb. 61 ft./lb.
12mm-1.75.....	8.8.....	65 ft./lb. 60 ft./lb.
14mm-2.0.....	8.8.....	104 ft./lb. 97 ft./lb.

All illustrations and specifications contained herein are based on the latest information available at the time of publication approval. ROADMASTER, INC. reserves the right to make changes at any time without notice in material, specification and models or to discontinue models.

KIT# 523171-1

02/20/13
KS

Align this edge with the top of the grille insert

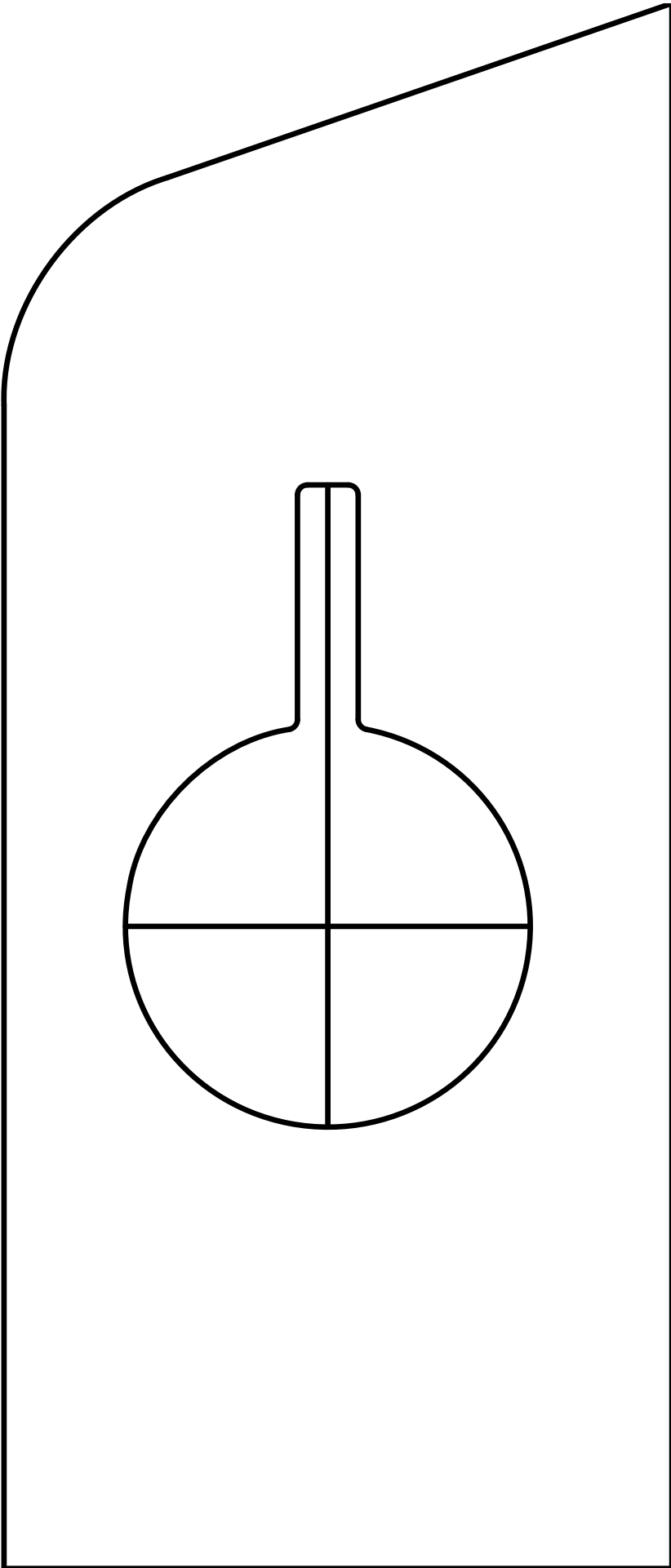

KIT# 523171-1

02/20/13
KS

Align this edge with the top of the grille insert

