



BASEPLATE KIT INSTALLATION INSTRUCTIONS

KIT# 523178-4

12/27/16
KS

ROADMASTER, Inc. 6110 NE 127th Ave. Vancouver, WA 98682 360-896-0407 fax 360-735-9300 www.roadmasterinc.com

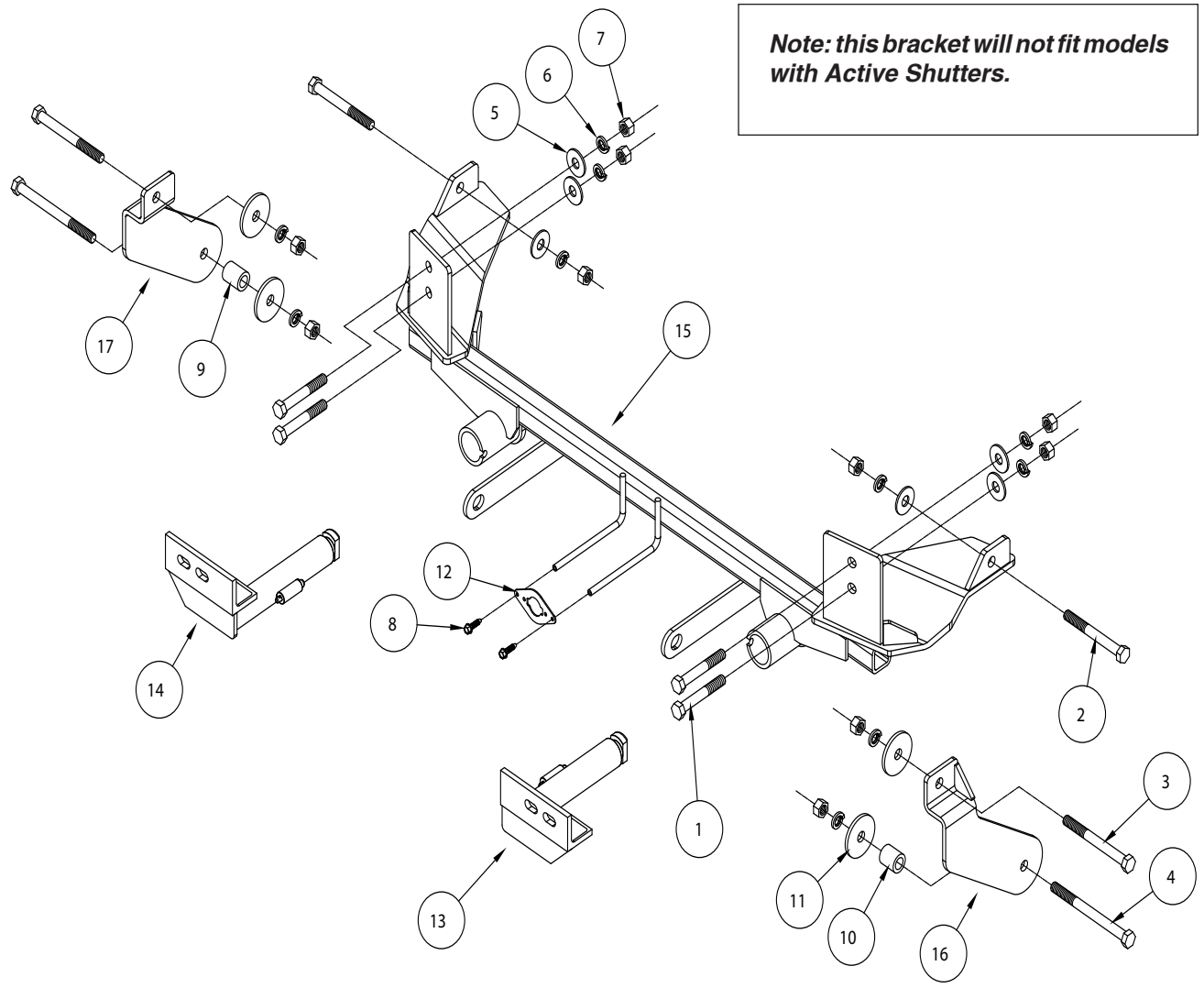

Note: this bracket will not fit models with Active Shutters.

ITEM	QTY	NAME	PART #
1	4	1/2" x 3 1/2" BOLT	350103-00
2	2	1/2" x 4 1/2" BOLT	350106-00
3	2	1/2" x 5" BOLT	350107-00
4	2	1/2" x 6" BOLT	350109-00
5	6	1/2" FLAT WASHER	350308-00
6	10	1/2" LOCK WASHER	350309-00
7	10	1/2" HEX NUT	350258-00
8	2	#10 x 3/4" SELF DRILLING SCREW	350247-35
9	1	1" O.D. x 0.188 WALL x 1 1/4" LONG TUBE SPACER	A-001493
10	1	1" O.D. x 0.188 WALL x 1 1/8" LONG TUBE SPACER	A-002410
11	4	1/2" PLATE WASHER	A-003086
12	1	WIRE PLUG PLATE	A-003801
13	1	DRIVER SIDE ARM	C-002715
14	1	PASSENGER SIDE ARM	C-002716
15	1	MAIN RECEIVER	C-002717
16	1	DRIVER SIDE BRACE	C-003102
17	1	PASSENGER SIDE BRACE	C-003103



BASEPLATE KIT INSTALLATION INSTRUCTIONS

KIT# 523178-4

12/27/16
KS

ROADMASTER, Inc. 6110 NE 127th Ave. Vancouver, WA 98682 360-896-0407 fax 360-735-9300 www.roadmasterinc.com

This is one of our EZ4 Twistlock series brackets, which allows the visible front portion of the bracket to be easily removed from the front of the vehicle (Fig.A and Fig.B). The bracket consists of a main receiver brace, two removable front braces, and a hardware pack.

The main receiver brace mounts to the bumper core and frame rails. The removable front braces install in the main receiver brace.

Before starting the installation, lay out the kit components in order, as they will be used. This will give you a visual idea of how the components work, and will also confirm that everything is present and accounted for.



IMPORTANT: All baseplates **must** be assembled with all the bolts left loose for final adjustment and positioning (before tightening) unless otherwise instructed. All bolts **must** be torqued for proper strength. If more than one bolt is used per fastening point, the diagram may only show one. Use flat washers over all slotted holes and lock washers on all fasteners.

WARNING

Failure to heed these warnings or follow the installation instructions may result in a voided warranty, loss of towed vehicle, personal injury or death.

- Do not weld or modify this baseplate or its components. Welding or modification will void the warranty.
- Do not use this document as a basis to design/fabricate a baseplate, as it may not show all parts or structural components.
- We strongly recommend professional installation.
- If the towed vehicle has been in an accident, it must be properly repaired before attaching the baseplate. Do not install the baseplate if any structural frame damage is found.
- The installer must use all bolts and parts supplied. If running changes were made by the vehicle manufacturer after this kit was designed, some bolts or other fasteners may no longer be the correct size. It is the installer's responsibility to verify this kit is securely fastened to the vehicle.
- Use Loctite® Red on all bolts used to secure this baseplate. Torque all bolts to the specifications found at the end of these instructions. Do not over-torque the bolts or failure may occur.
- The installer must inspect the baseplate to ensure adequate clearance, particularly around hoses, air conditioner lines, radiators, etc. or non-warranty failure may result.
- Roadmaster manufactures many styles of baseplates. If your baseplate has removable arms, they must be removed before driving the vehicle, unless the arms can be pinned or padlocked in place. If not secured, the arms could vibrate out.
- Some motorhome chassis have such a tight turning radius that you can damage your motorhome, towed vehicle, tow bar or baseplate while turning sharply. Before getting on the road, test your turning radius in an empty parking lot. Turning too sharply could result in non-warranty damage to your towing system, motorhome and/or towed vehicle.
- Do not back up with the towed vehicle attached or non-warranty damage will occur to your towing system or vehicles.
- The safety cables must connect the towing vehicle to the towed vehicle frame to frame, with the cables crossed, with enough slack for sharp turns. See cable instructions for proper routing. Failure to do so will result in non-warranty damage and/or the loss of the towed vehicle.
- This kit is designed for use with ROADMASTER tow bars and ROADMASTER adapters only. Using this kit with other brands, without an approved ROADMASTER adapter, may result in non-warranty damage or injury.
- Receiver extensions and out-of-level towing situations of 3 inches or more. This can cause the system to swing much higher and lower, causing excessive strain on the tow bar, baseplate and frame. That can cause the towing system to fail, causing property damage, personal injury or even death. If you must use a receiver extension or drop hitch to tow, it will reduce your receiver's weight capacity by 1/3 to avoid damaging your system. Never use more than one extension and/or drop hitch, as this will void your warranty.
- Every 3,000 miles, the owner must inspect all mounting points for cracks or fatigue, and check the fasteners for proper torque, according to the bolt torque requirements chart on the last page of these instructions.
- The owner must follow the vehicle manufacturer's instructions to prepare the vehicle for towing. Failure to do so may cause severe damage to the vehicle.
- This baseplate is only warranted for the original installation. Installing a used baseplate on another vehicle is not recommended and will void the warranty.



BASEPLATE KIT INSTALLATION INSTRUCTIONS

KIT# 523178-4

12/27/16
KS

ROADMASTER, Inc. 6110 NE 127th Ave. Vancouver, WA 98682 360-896-0407 fax 360-735-9300 www.roadmasterinc.com

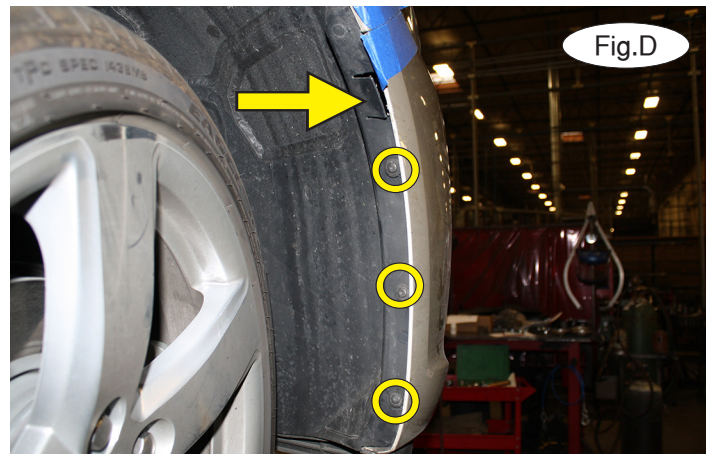
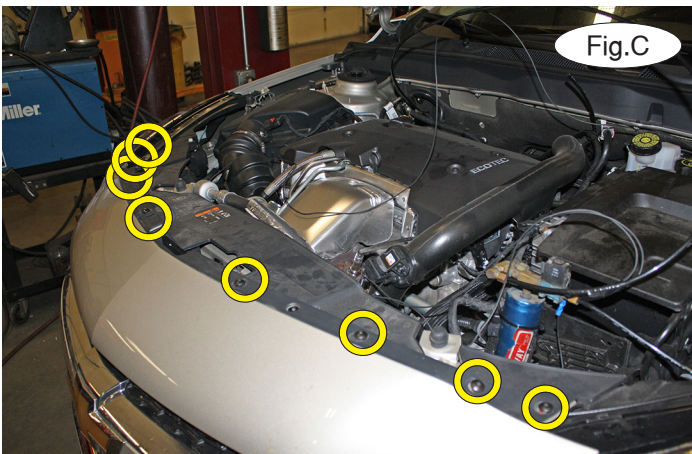

1. **Important:** please use all supplied bolts and parts and read all instructions carefully before beginning this installation. The majority of questions you may have can be answered within the text, and proper installation will ensure safe and secure travel. **Note: this bracket will not fit models with Active Shutters.** Now, begin the installation by removing eight T20 Torx screws attaching the top of the fascia to the core support (Fig.C).

2. On each side, remove three T15 Torx screws attaching the fascia to the fender liner and one 7mm (head) screw attaching the fascia to the fender (Fig.D). **Note:** the arrow denotes the approximate location of the 7mm (head) screw behind the flap.

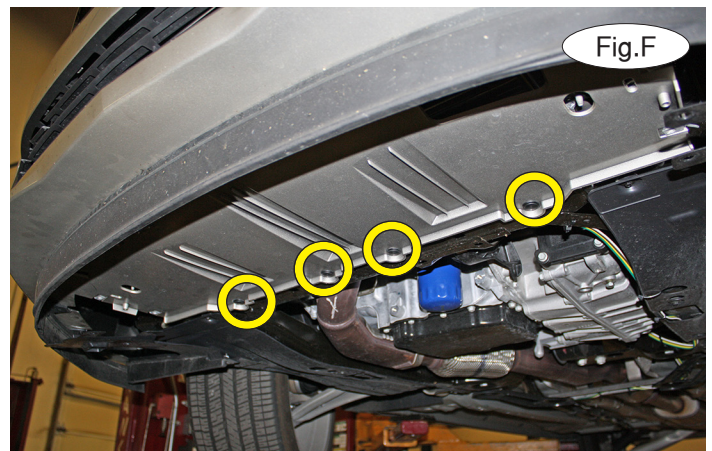

3. On each side, remove five 7mm (head) screws attaching the fender liner to the fascia and the fascia to the radiator (Fig.E).

4. Remove four plastic fasteners attaching the fascia to the subframe (Fig.F).

5. Pull out on the corners of the fascia and up on the top of the fascia to remove it (Fig.G). Disconnect the fog lights and ambient temperature sensor.

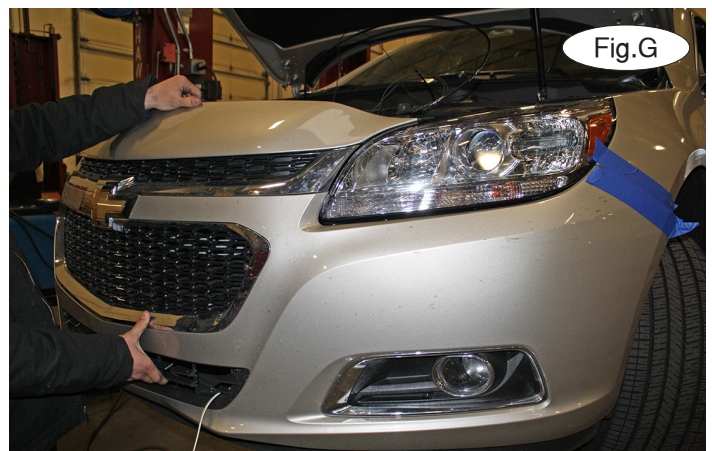



BASEPLATE KIT INSTALLATION INSTRUCTIONS

KIT# 523178-4

12/27/16
KS

ROADMASTER, Inc. 6110 NE 127th Ave. Vancouver, WA 98682 360-896-0407 fax 360-735-9300 www.roadmasterinc.com

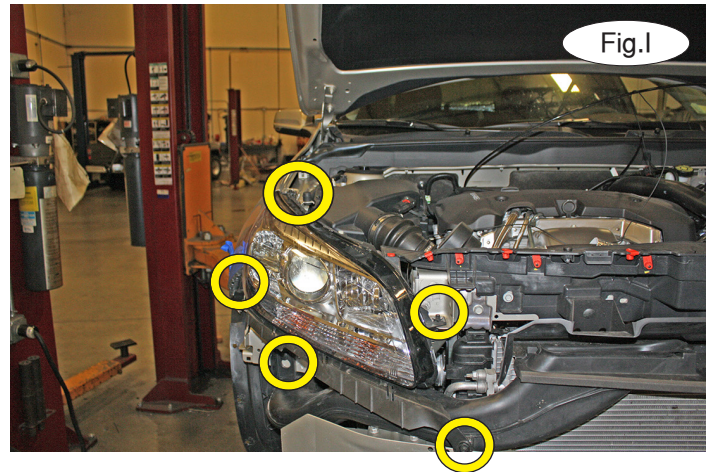
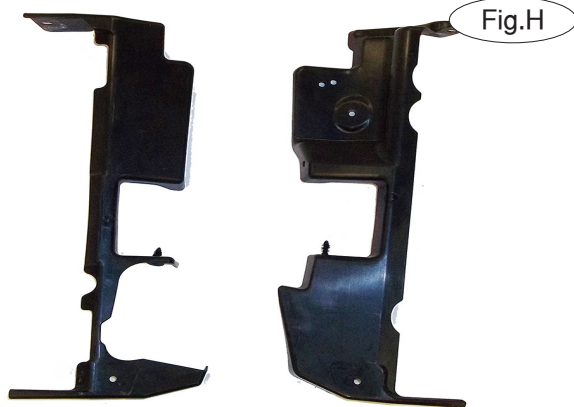

6. From the bottom of the driver's side air deflector, disconnect the ambient temperature sensor wiring loom. On each side, remove the air deflectors by removing three plastic fasteners (Fig.H). *Note:* they will not be replaced. Retain the air deflectors and their plastic fasteners for replacement in case the bracket is ever removed from the vehicle.

7. On each side, remove four 7mm (head) screws attaching the headlight to the unibody and set aside for now. *Note:* the passenger side has five 7mm (head) screws (Fig.I).

8. Remove three plastic fasteners attaching the air intake to the unibody and set it aside (Fig.J).

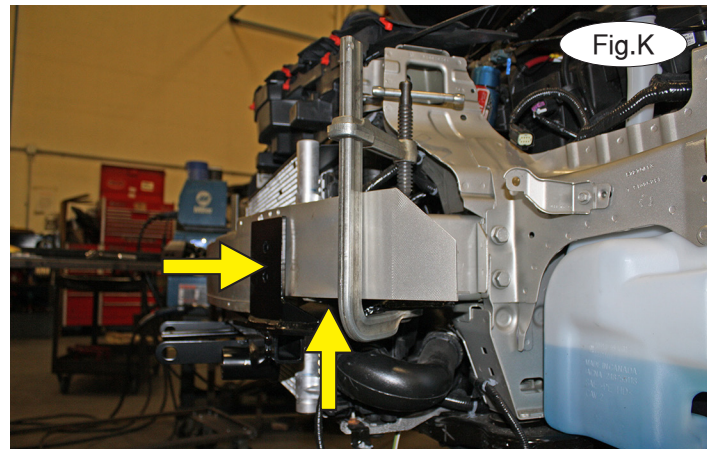
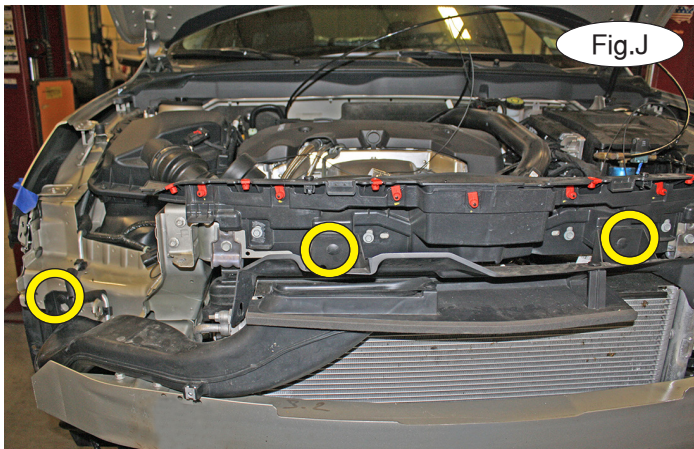

9. Place the main receiver brace under and around the bumper core and, ensuring that it is flush with the face and underside of the bumper core, clamp it in place (Fig.K).

10. On each side, using the side mounting point of the main receiver brace as a template, and ensuring that the drill is level, drill straight through the entire frame rail (Fig.L). *Note:* use a proper-length drill bit and caution to avoid damaging engine components.





BASEPLATE KIT INSTALLATION INSTRUCTIONS

KIT# 523178-4

12/27/16
KS

ROADMASTER, Inc. 6110 NE 127th Ave. Vancouver, WA 98682 360-896-0407 fax 360-735-9300 www.roadmasterinc.com

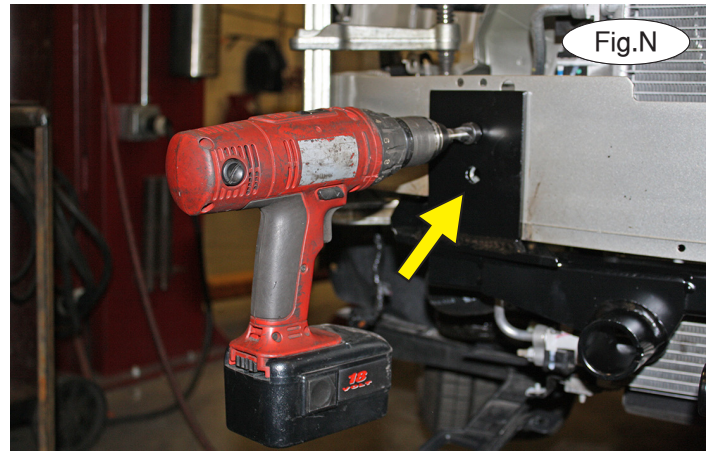
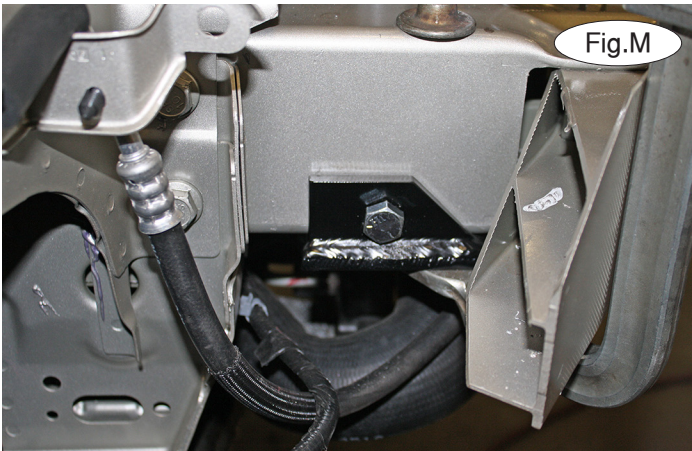

11. On each side, bolt through the hole you drilled in the previous step using the supplied $\frac{1}{2}$ " x $4\frac{1}{2}$ " bolt and finish with a $\frac{1}{2}$ " flat washer, lock washer and nut (Fig.M). *Note:* ensure proper alignment, as the bolts will receive Loctite® Red and will be torqued at the end of these instructions.

12. On each side, using the two front mounting points of the main receiver brace as templates, and ensuring that the drill is level, drill through the front of the bumper core (Fig.N). *Note:* use a proper-sized drill bit and caution to avoid damaging engine components.

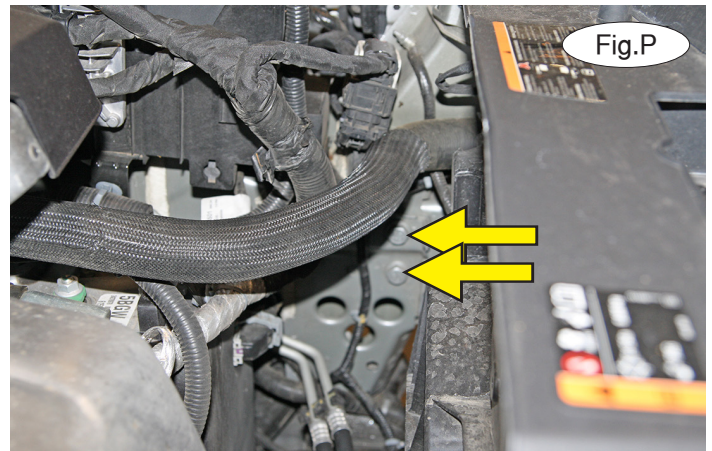
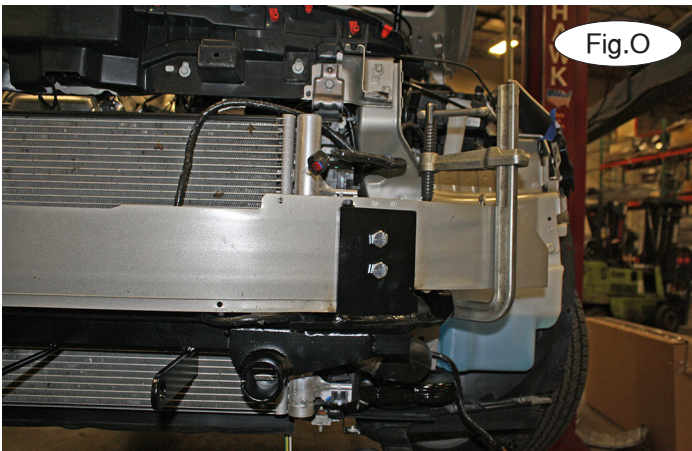

13. On each side, bolt through the holes you drilled in the previous step using the supplied $\frac{1}{2}$ " x $3\frac{1}{2}$ " bolts and finish with $\frac{1}{2}$ " flat washers, lock washers and nuts (Fig.O).

14. On each side, locate the two 18mm (head) bolts on the inside of the frame rail (Fig.P). Tighten these two bolts.

15. On each side, on the outside of the frame, locate two 18mm (head) frame bolts (Fig.Q) and remove them. Place Loctite® Red on the bolts and replace them and tighten.

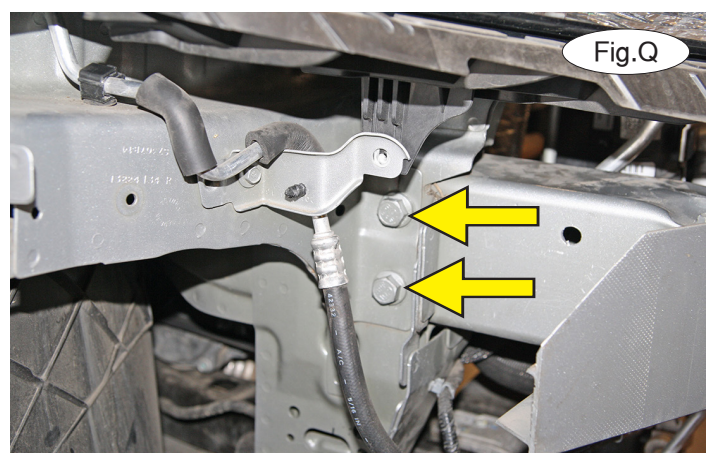



BASEPLATE KIT INSTALLATION INSTRUCTIONS

KIT# 523178-4

12/27/16
KS

ROADMASTER, Inc. 6110 NE 127th Ave. Vancouver, WA 98682 360-896-0407 fax 360-735-9300 www.roadmasterinc.com



16. On each side, on the outside of the frame rail, measure up 2" and over 1", perpendicular to the frame edge. Mark a hole, and then drill using a $\frac{1}{2}$ " bit (Fig.R). *Note:* ensure that the drill is straight and level, and then drill all the way through the frame, ensuring you do not contact engine components.

17. On the passenger side, place a $\frac{1}{2}$ " x 6" bolt through the lower mount of the rear support brace, a $1\frac{1}{4}$ " pipe spacer, and through the hole you drilled in the previous step (Fig.S). Finish with a $\frac{1}{2}$ " plate washer, lock washer and nut.

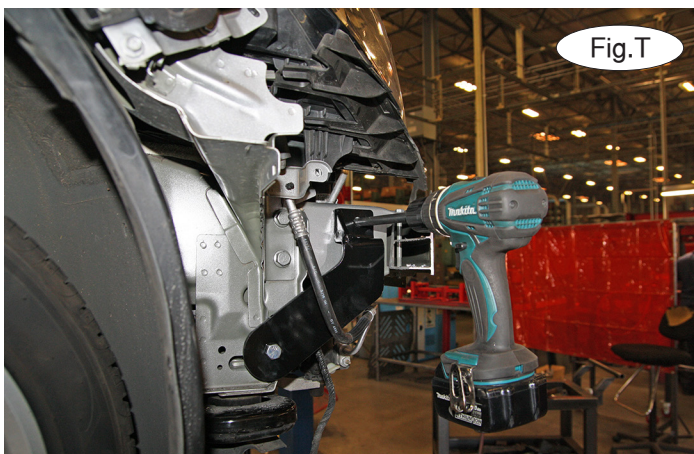

18. Level the bracket and then use the upper mount as a template for drilling a $\frac{1}{2}$ " hole (Fig.T). *Note:* ensure that the drill is straight and level, and then drill all the way through the frame, ensuring you do not contact engine components.

19. Bolt through the upper mount of the passenger side rear support brace using the supplied $\frac{1}{2}$ " x 5" bolt and finish with a $\frac{1}{2}$ " plate washer, lock washer and nut (Fig.U). *Note:* carefully bend the cooling line out of the way to allow clearance of the bolt (Fig.V).

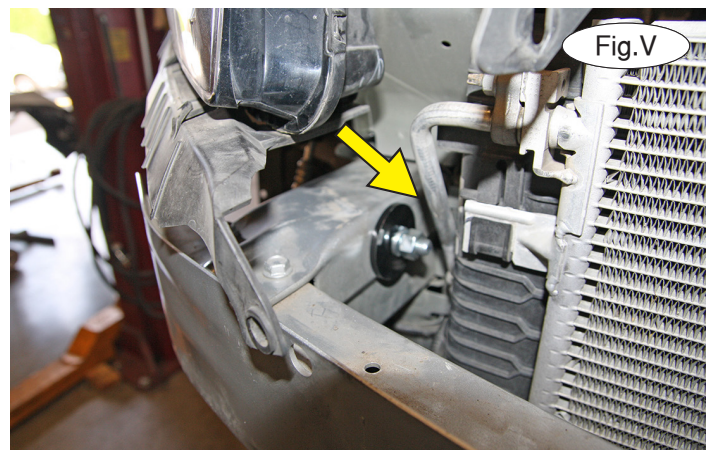



BASEPLATE KIT INSTALLATION INSTRUCTIONS

KIT# 523178-4

12/27/16
KS

ROADMASTER, Inc. 6110 NE 127th Ave. Vancouver, WA 98682 360-896-0407 fax 360-735-9300 www.roadmasterinc.com

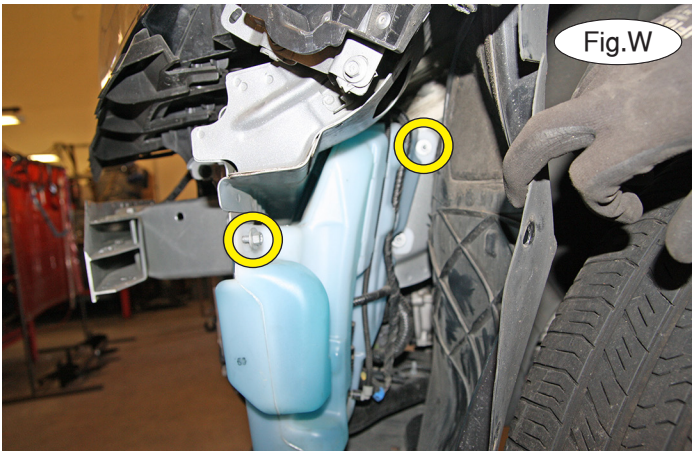

20. On the driver's side, remove two 10mm nuts attaching the washer bottle to the frame (Fig.W) and push it out of the way for now.

21. Repeat steps 17 through 19 but use a 1-1/8" pipe spacer instead (Fig.X).

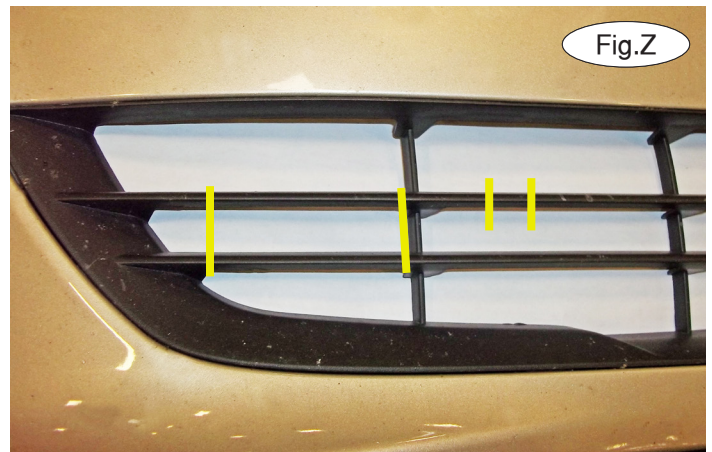
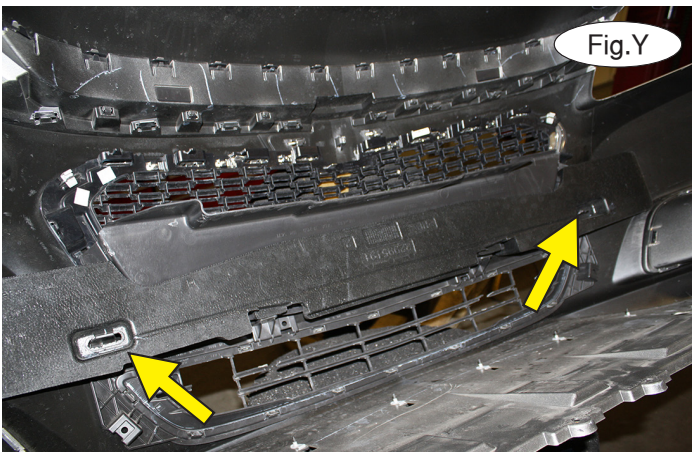

22. Tighten all bolts to the bolt torque requirements found at the end of these instructions. *Note:* use Loctite® Red on all nuts and bolts.

23. Remove the foam shock absorption pad from the back of the fascia by releasing the two clips (Fig.Y). *Note:* it will not be replaced. Retain the foam shock absorption pad for replacement in case the bracket is ever removed from the vehicle.

24. Reverse steps 7 and 8 to reinstall the headlights and air ducting.

25. Hold the fascia in place over the main receiver brace and mark it for trimming. Using the yellow lines in Figure Z as a reference, trim the fascia to allow clearance for the main receiver brace.



BASEPLATE KIT INSTALLATION INSTRUCTIONS

KIT# 523178-4

12/27/16
KS

ROADMASTER, Inc. 6110 NE 127th Ave. Vancouver, WA 98682 360-896-0407 fax 360-735-9300 www.roadmasterinc.com

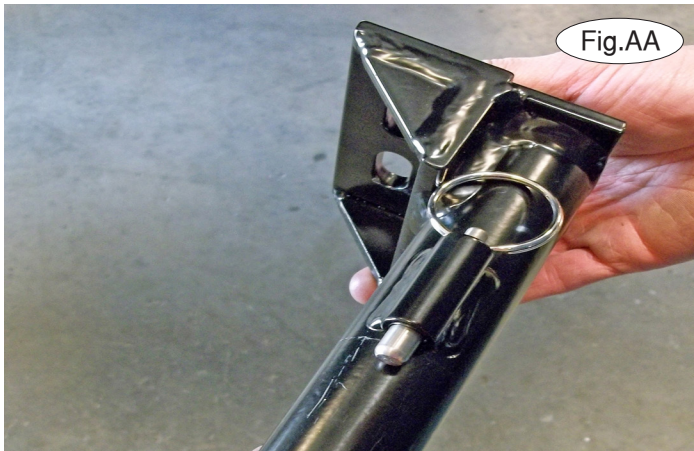

26. Reinstall the fascia, reversing steps 1 through 5.

27. **Note: the following four images are for illustration purposes only, as your specific application may be slightly different.**

The spring-loaded pin on the removable arm snaps into a notch on the receiver, locking the removable arm into its final towing position. Before inserting each arm into the receiver, verify that the spring is working by ensuring that the spring-loaded pin moves easily back and forth within the barrel when pulled and that it can be pulled flush with the face of the barrel (Fig.AA and Fig.BB).

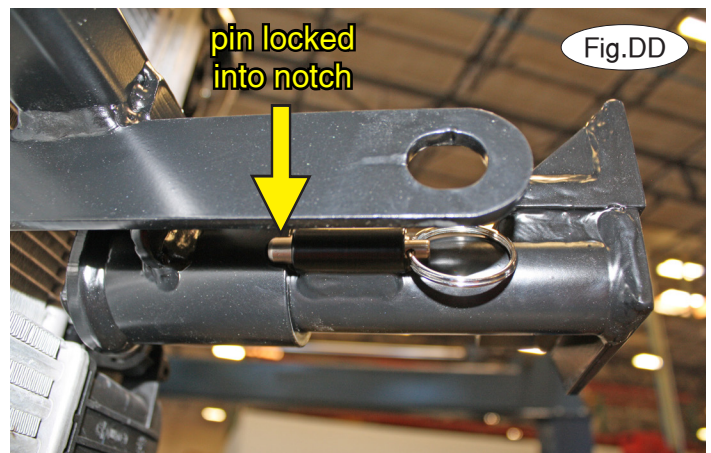
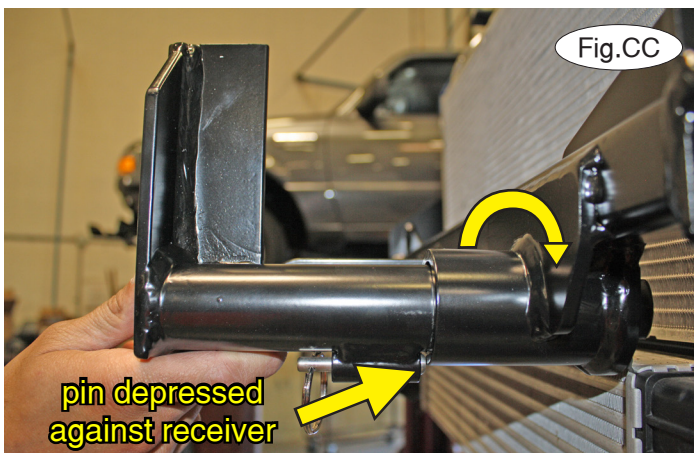

28. On each side, insert the removable front bracket arm into the front receiver 90 degrees from its final towing position, depressing the spring-loaded pin against the receiver (Fig.CC). Now, twist back 90 degrees until the spring-loaded pin snaps into place in the notch on the receiver, locking the arm into place in its final towing position (Fig.DD).

Please note: it is the owner's responsibility to ensure the locking of the pins before towing. Otherwise, failure of the towing system will result.

29. Install the tow bar to the mounting bracket according to the manufacturer's instructions.



BASEPLATE KIT INSTALLATION INSTRUCTIONS

KIT# 523178-4

12/27/16
KS

ROADMASTER, Inc. 6110 NE 127th Ave. Vancouver, WA 98682 360-896-0407 fax 360-735-9300 www.roadmasterinc.com

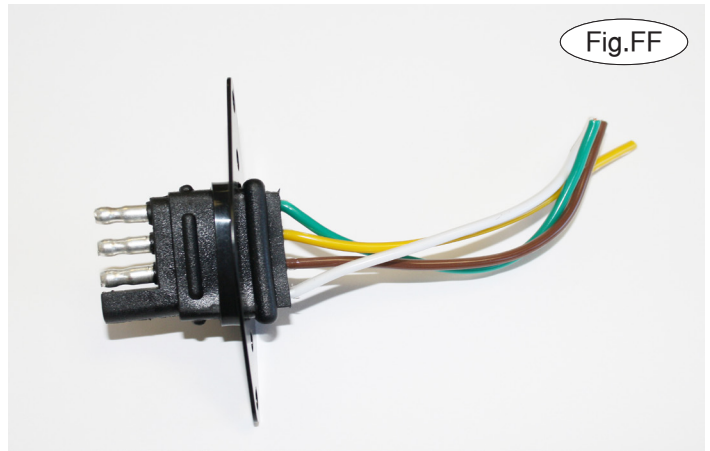
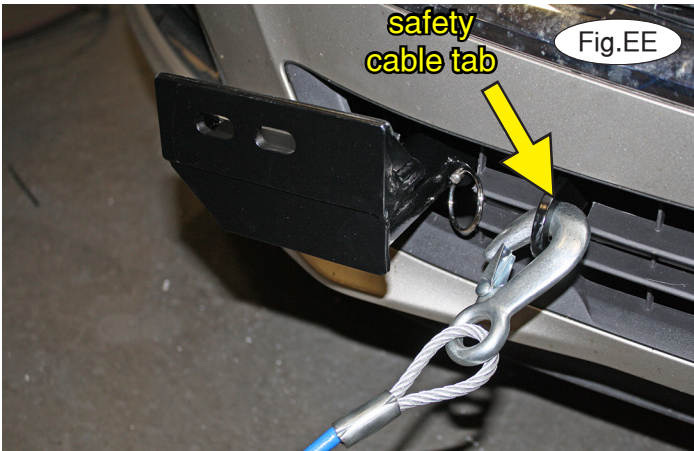

IMPORTANT!

Safety cables are required by law. When towing, connect safety cables to the safety cable tabs illustrated in Figure EE. Make certain there is adequate slack in the cables to allow a full turning radius; otherwise, damage will result. If necessary, longer cables or cable extensions are available.

Note: if the bracket is so equipped, the holes in the alignment tabs which are welded to the arms and main receivers are for padlocks only. Under no circumstances should you bolt the alignment tabs together. Bolting the alignment tabs together may result in non-warranty damage to the bracket.

Three options for attaching the wiring plug to the main receiver brace

For six-wire plugs: use the two supplied 3/4" self-tapping screws to attach the electrical plug directly to the rods on the front of the main receiver brace.

For four-wire round plugs: attach to the plug mounting plate and then use the two supplied 3/4" self-tapping screws to attach the mounting plate to the rods on the front of the main receiver brace.

For four-wire flat plugs: place the plug through the mounting plug plate, and then secure it using the supplied zip tie on the front of the plug (Fig.FF). Use the two supplied 3/4" self-tapping screws to attach the mounting plate to the rods on the front of the main receiver brace.

BOLT TORQUE REQUIREMENTS

Note: The torque values represented below are intended as general guidelines. Torque requirements for specific applications may vary. Roadmaster does not warrant this information to be accurate for all applications and disclaims all liability for any claims or damages which may result from its use.

STANDARD BOLTS

Thread Size	Grade	Torque
5/16.....	5.....	13 ft./lb.
3/8.....	5.....	23 ft./lb.
7/16.....	5.....	37 ft./lb.
1/2.....	5.....	56 ft./lb.
5/8.....	5.....	150 ft./lb.

METRIC BOLTS

Thread Size	Grade	Plated / Unplated
8mm-1.0	8.8	20 ft./lb. 18 ft./lb.
8mm-1.25	8.8	19 ft./lb. 18 ft./lb.
10mm-1.25	8.8	38 ft./lb. 36 ft./lb.
10mm-1.5	8.8	37 ft./lb. 35 ft./lb.

METRIC BOLTS

Thread Size	Grade	Plated / Unplated
12mm-1.25	8.8	70 ft./lb. 65 ft./lb.
12mm-1.5	8.8	66 ft./lb. 61 ft./lb.
12mm-1.75	8.8	65 ft./lb. 60 ft./lb.
14mm-2.0	8.8	104 ft./lb. 97 ft./lb.

All illustrations and specifications contained herein are based on the latest information available at the time of publication approval. ROADMASTER, INC. reserves the right to make changes at any time without notice in material, specification and models or to discontinue models.