



BASEPLATE KIT INSTALLATION INSTRUCTIONS

KIT# 523179-5

10/29/19
KS

ROADMASTER, Inc. 6110 NE 127th Ave. Vancouver, WA 98682 360-896-0407 fax 360-735-9300 www.roadmasterinc.com

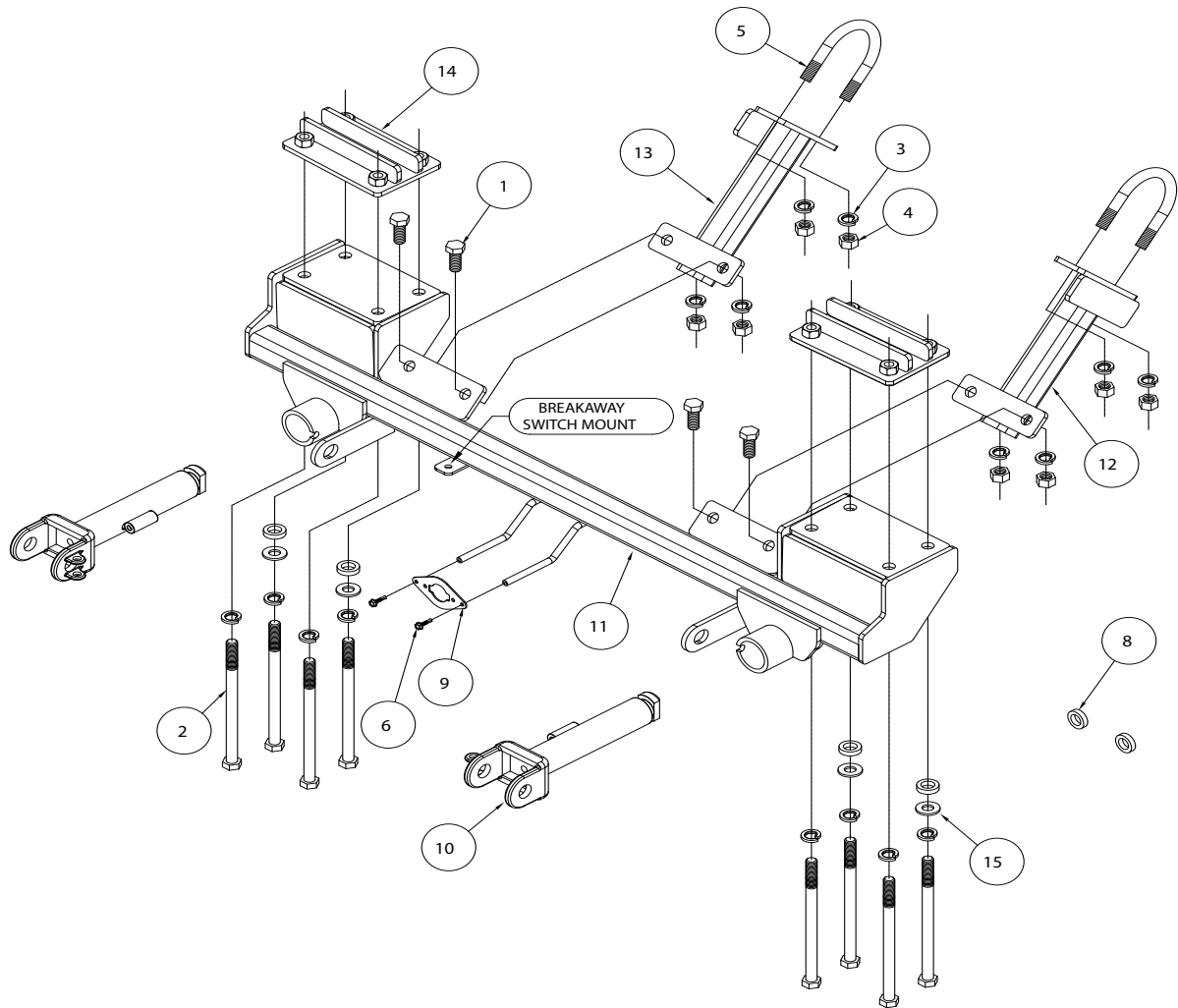

ITEM	QTY	NAME	PART #
1	4	1/2" x 1 1/4" BOLT	350094-00
2	8	1/2" x 7 1/2" BOLT	350112-80
3	16	1/2" LOCK WASHER	350309-00
4	8	1/2" HEX NUT	350258-00
5	2	1/2" x 3" x 3 1/2" U-BOLT	357019-00
6	2	#10 x 3/4" SELF DRILLING SCREW	350247-35
7	4	ZIP TIE	300140-8
8	6	1" O.D. x 0.188 WALL x 1/4" LONG TUBE SPACER	A-001022
9	1	WIRE PLUG PLATE	A-003801
10	2	ARM	C-002383
11	1	MAIN RECEIVER	C-002769
12	1	DRIVER SIDE BRACE	C-002770
13	1	PASSENGER SIDE BRACE	C-002771
14	2	BACKING PLATE	C-002772
15	4	1/2" SAE FLAT WASHER	350308-20

Important

Note: this bracket will not accommodate the Guardian rock shield, some models of the Tow Defender, Stowaway or the StowMaster and StowMaster All Terrain tow bars.



BASEPLATE KIT INSTALLATION INSTRUCTIONS

KIT# 523179-5

10/29/19
KS

ROADMASTER, Inc. 6110 NE 127th Ave. Vancouver, WA 98682 360-896-0407 fax 360-735-9300 www.roadmasterinc.com

This is one of our direct-connect series baseplates, which allows the visible front portion of the kit to be easily removed from the front of the vehicle (Fig.A and Fig.B). The bracket consists of a main receiver brace, two rear braces, two removable front braces, and a hardware pack.

The main receiver brace mounts to the frame rails and rear braces. The removable front braces install in the main receiver brace.

Before starting the installation, lay out the kit components in order, as they will be used. This will give you a visual idea of how the components work, and will also confirm that everything is present and accounted for.



Fig.A



Fig.B

IMPORTANT: All baseplates **must** be assembled with all the bolts left loose for final adjustment and positioning (before tightening) unless otherwise instructed. All bolts **must** be torqued for proper strength. If more than one bolt is used per fastening point, the diagram may only show one. Use flat washers over all slotted holes and lock washers on all fasteners.

WARNING

Failure to heed these warnings or follow the installation instructions may result in a voided warranty, loss of towed vehicle, personal injury or death.

- Do not weld or modify this baseplate or its components. Welding or modification will void the warranty.
- Do not use this document as a basis to design/fabricate a baseplate, as it may not show all parts or structural components.
- We strongly recommend professional installation.
- If the towed vehicle has been in an accident, it must be properly repaired before attaching the baseplate. Do not install the baseplate if any structural frame damage is found.
- The installer must use all bolts and parts supplied. If running changes were made by the vehicle manufacturer after this kit was designed, some bolts or other fasteners may no longer be the correct size. It is the installer's responsibility to verify this kit is securely fastened to the vehicle.
- Use Loctite® Red on all bolts used to secure this baseplate. Torque all bolts to the specifications found at the end of these instructions. Do not over-torque the bolts or failure may occur.
- The installer must inspect the baseplate to ensure adequate clearance, particularly around hoses, air conditioner lines, radiators, etc. or non-warranty failure may result.
- Roadmaster manufactures many styles of baseplates. If your baseplate has removable arms, they must be removed before driving the vehicle, unless the arms can be pinned or padlocked in place. If not secured, the arms could vibrate out.
- Some motorhome chassis have such a tight turning radius that you can damage your motorhome, towed vehicle, tow bar or baseplate while turning sharply. Before getting on the road, test your turning radius in an empty parking lot. Turning too sharply could result in non-warranty damage to your towing system, motorhome and/or towed vehicle.
- Do not back up with the towed vehicle attached or non-warranty damage will occur to your towing system or vehicles.
- The safety cables must connect the towing vehicle to the towed vehicle frame to frame, with the cables crossed, with enough slack for sharp turns. See cable instructions for proper routing. Failure to do so will result in non-warranty damage and/or the loss of the towed vehicle.
- This kit is designed for use with ROADMASTER tow bars and ROADMASTER adapters only. Using this kit with other brands, without an approved ROADMASTER adapter, may result in non-warranty damage or injury.
- Receiver extensions and out-of-level towing situations of 3 inches or more. This can cause the system to swing much higher and lower, causing excessive strain on the tow bar, baseplate and frame. That can cause the towing system to fail, causing property damage, personal injury or even death. If you must use a receiver extension or drop hitch to tow, it will reduce your receiver's weight capacity by 1/3 to avoid damaging your system. Never use more than one extension and/or drop hitch, as this will void your warranty.
- Every 3,000 miles, the owner must inspect all mounting points for cracks or fatigue, and check the fasteners for proper torque, according to the bolt torque requirements chart on the last page of these instructions.
- The owner must follow the vehicle manufacturer's instructions to prepare the vehicle for towing. Failure to do so may cause severe damage to the vehicle.
- This baseplate is only warranted for the original installation. Installing a used baseplate on another vehicle is not recommended and will void the warranty.



BASEPLATE KIT INSTALLATION INSTRUCTIONS

KIT# 523179-5

10/29/19
KS

ROADMASTER, Inc. 6110 NE 127th Ave. Vancouver, WA 98682 360-896-0407 fax 360-735-9300 www.roadmasterinc.com

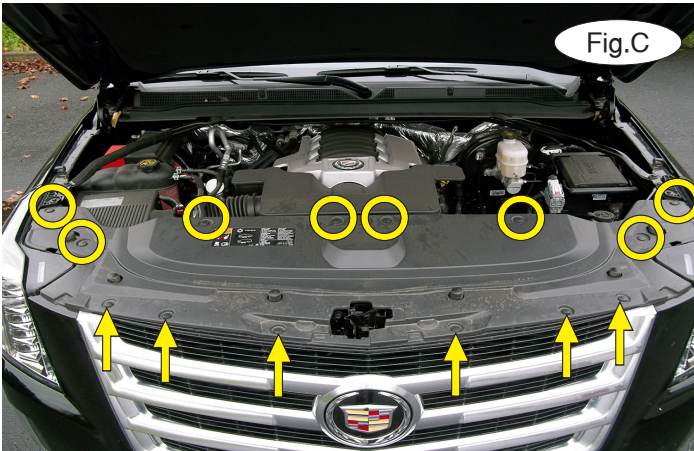

1. **Important:** please use all supplied bolts and parts and read all instructions carefully before beginning this installation. The majority of questions you may have can be answered within the text, and proper installation will ensure safe and secure travel. Now, begin the installation by removing eight plastic fasteners (it may be six, in some instances) along the rear of the radiator cover (Fig. C – circles). Then, remove six plastic fasteners attaching the front of the radiator cover to the top of the fascia (Fig.C – arrows). *Note:* These could be clips instead, as shown in Figure D.

2. On each side, remove three 10mm (head) bolts attaching the upper fascia to the core support (Fig.E).



3. On each side, remove six 7mm screws attaching the fender liner to the fascia and the fascia to the fender (Fig.F). *Note:* due to manufacturing variances, there could be five screws instead.

4. On each side, remove one plastic fastener and three 10mm (head) bolts attaching the bottom of the fascia to the fender liner and support bracket (Fig.G).

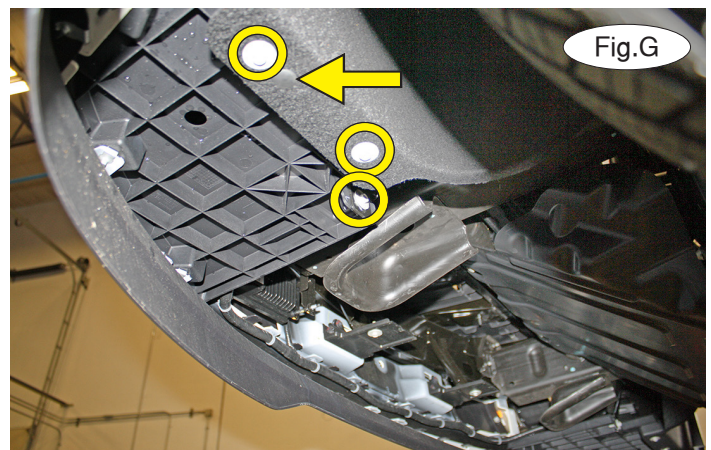



BASEPLATE KIT INSTALLATION INSTRUCTIONS

KIT# 523179-5

10/29/19
KS

ROADMASTER, Inc. 6110 NE 127th Ave. Vancouver, WA 98682 360-896-0407 fax 360-735-9300 www.roadmasterinc.com

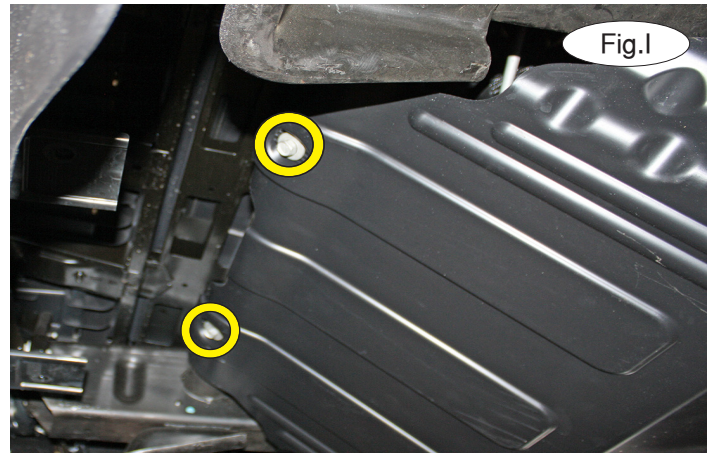

5. On each side, remove one 10mm (head) bolt attaching the fascia support to the bumper core (Fig.H).
6. Remove two 16mm (head) bolts and four 10mm (head) bolts attaching the skid plate to the frame (Fig.I and Fig.J).

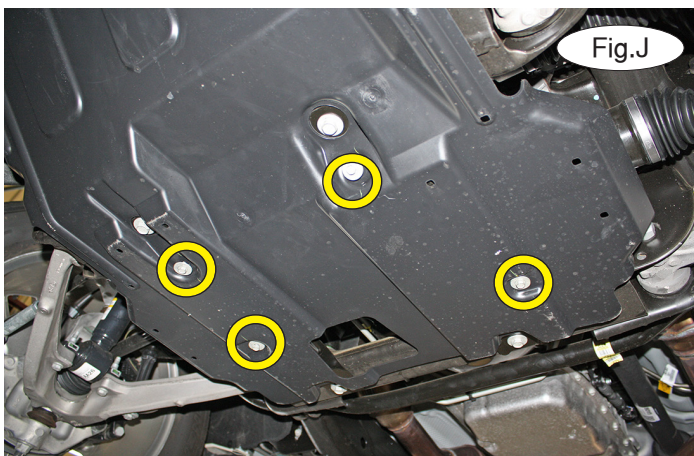

7. On each side, pull back the fender liner and loosen three 7mm screws attaching the fascia's locking strip to the vehicle (Fig.K).

8. Disconnect the wiring harness located on the top passenger side of the fascia (Fig.L).

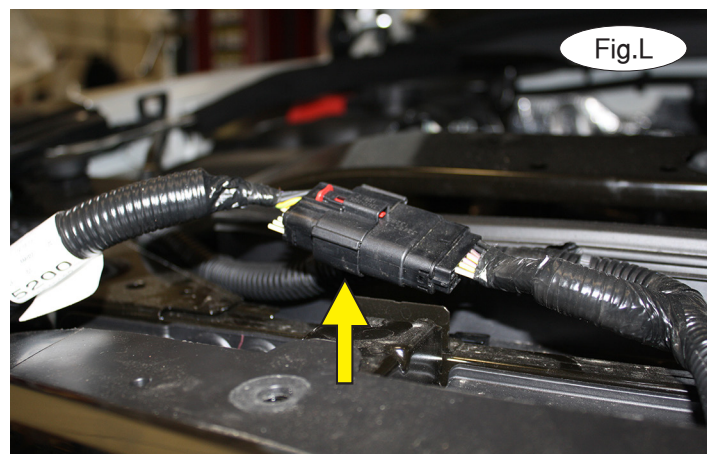



BASEPLATE KIT INSTALLATION INSTRUCTIONS

KIT# 523179-5

10/29/19
KS

ROADMASTER, Inc. 6110 NE 127th Ave. Vancouver, WA 98682 360-896-0407 fax 360-735-9300 www.roadmasterinc.com



9. On each side, in a recessed hole on the back of the fascia, locate and release a plastic clip attaching the fascia to the core support (Fig.M – yellow arrow). In order to release it, use a screwdriver and push up on the clip to release it. It helps to push out slightly on the bottom of the fascia. Now, pull out on each corner of the fascia to remove it (Fig.N).

10. Use a stand to hold the main receiver brace in place under the bumper core (Fig.O). **Caution! Under no circumstances should you attempt to move, adjust or disconnect the ACC unit (indicated in red in Figure O). Doing so may cause cruise control malfunction and/or computer error codes that may require the dealership to repair or reset.**

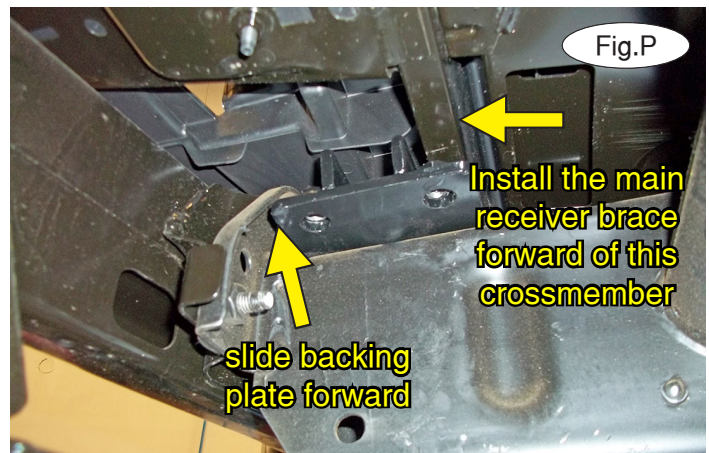

11. On each side, place one of the supplied backing plates over the top of the frame and **slide it as far forward as possible** (Fig.P). *Note:* refer to Figure P for clarification on where the main receiver brace installs.

Then, using the two supplied $\frac{1}{2}$ x $7\frac{1}{2}$ " bolts and $\frac{1}{2}$ " lock washers, bolt up through the main receiver brace and into the backing plate (Fig.Q). Repeat the process for the rear bolts but for each one, place a $\frac{1}{2}$ " lock washer, small $\frac{1}{2}$ " flat washer, and a 1" O.D. x .188 wall x $\frac{1}{4}$ " pipe spacer over the bolt before passing it through the main receiver brace and into the backing plate.





BASEPLATE KIT INSTALLATION INSTRUCTIONS

KIT# 523179-5

10/29/19
KS

ROADMASTER, Inc. 6110 NE 127th Ave. Vancouver, WA 98682 360-896-0407 fax 360-735-9300 www.roadmasterinc.com

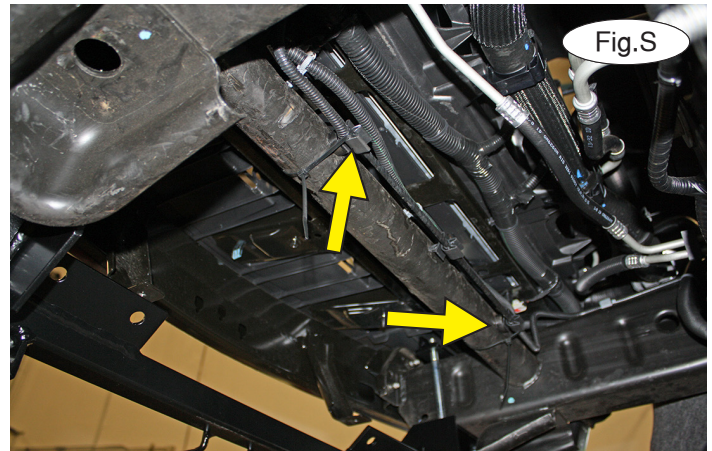
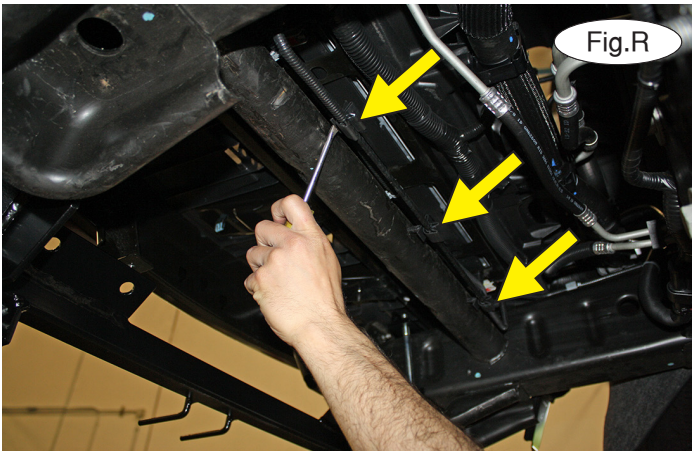

12. Carefully pull out the three fasteners securing the brake line to the crossmember (Fig.R). Then, pull out on one plastic clip attaching the wiring loom on each side of the crossmember. Place two of the supplied $\frac{1}{4}$ " x 1" x .188 pipe spacers between the two outside fasteners of the brake line and zip tie the line to the crossmember, securing the pipe spacers in place (Fig.S).

13. On each side, place the rear brace below the crossmember and place the U bolt around the crossmember, and bolt through the rear brace, finishing with a $\frac{1}{2}$ " lock washer and nut (Fig.T). *Note:* make certain that the gusset of the rear brace faces to the outside of the vehicle. *Note:* ensure proper alignment, as the bolts will receive Loctite® Red and will be torqued at the end of these instructions.

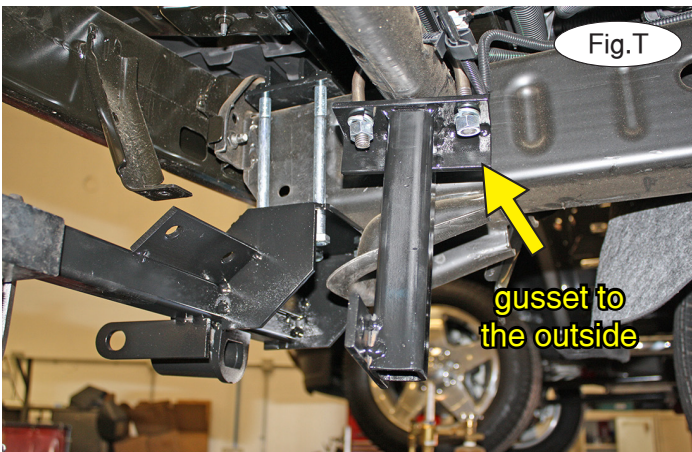

14. On each side, bolt the rear brace to the main receiver brace using two of the $\frac{1}{2}$ " x $1\frac{1}{4}$ " bolts. Bolt through the rear brace and the main receiver brace and finish with $\frac{1}{2}$ " lock washers and nuts (Fig.U).



BASEPLATE KIT INSTALLATION INSTRUCTIONS

KIT# 523179-5

10/29/19
KS

ROADMASTER, Inc. 6110 NE 127th Ave. Vancouver, WA 98682 360-896-0407 fax 360-735-9300 www.roadmasterinc.com

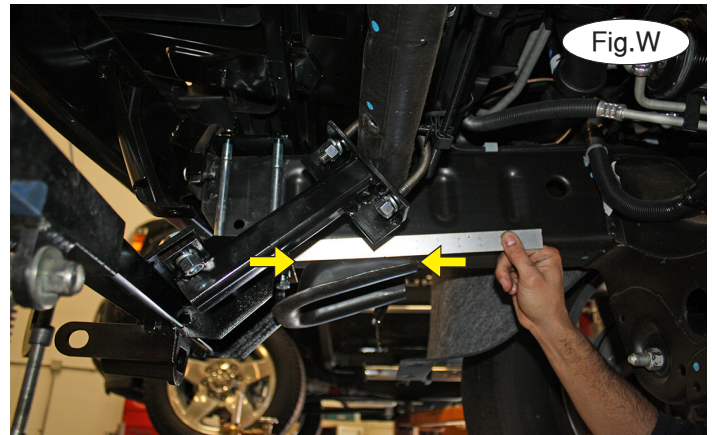
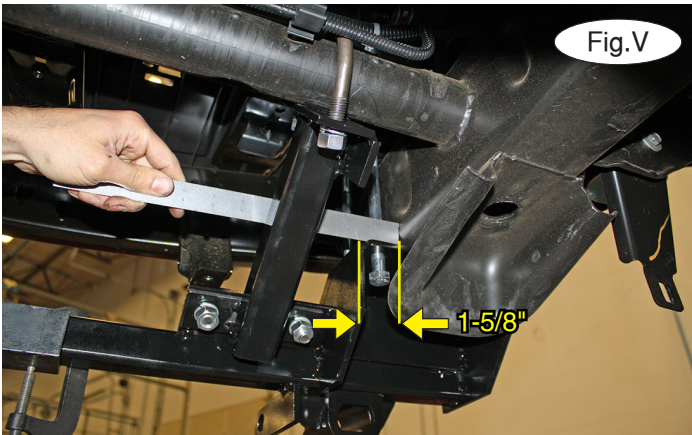

15. Make certain the bracket is even from side-to-side by measuring. First, measure from the inside of the frame to the outside edge of the vertical plate of the main receiver brace. The distance should be approximately 1-5/8" (Fig.V). Then, measure from the back edge of the horizontal plate of the main receiver brace to the back edge of the frame guard, ensuring that the measurement is equal on both sides of the vehicle (Fig.W). Then, tighten all bolts to the bolt torque requirements found at the end of these instructions. *Note:* use Loctite® Red on all nuts and bolts.

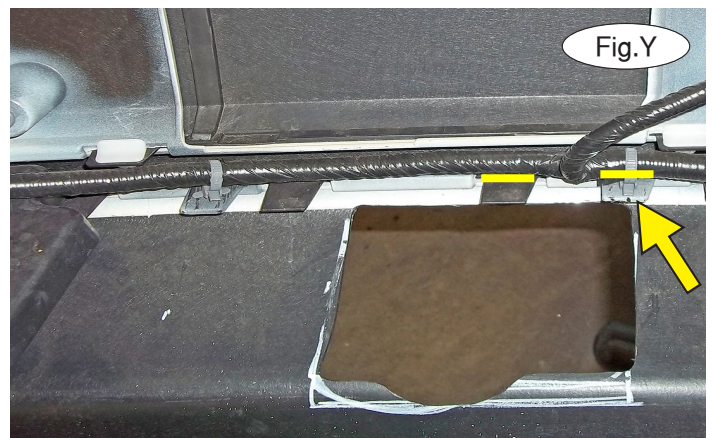
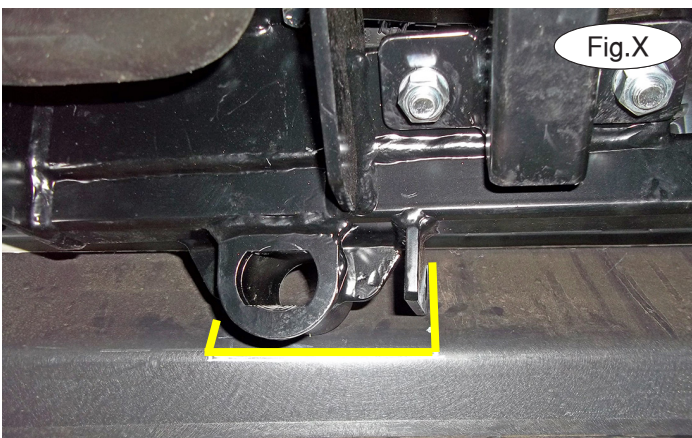

16. Temporarily hold the fascia in place over the receivers by replacing two of the 10mm (head) bolts you removed in step 2 to secure it in place. Then, mark inside the fascia for the trimming as shown, using the yellow lines in Figure X as a reference for trimming an approximately 5" square hole on each side (Fig.Y). You will also need to remove the plastic fastener attaching the wiring harness to the tab (yellow arrow) and then trim off the two tabs indicated with yellow lines (Fig.Y). *Note:* trim the tab indicated in Figure Z for Escalade models. Trimming may vary slightly.

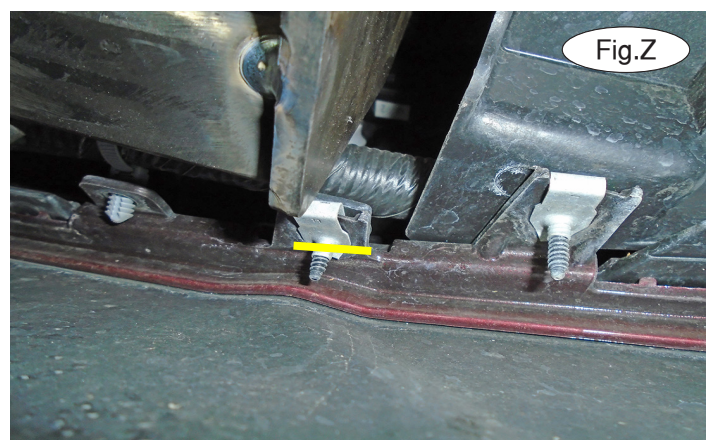



BASEPLATE KIT INSTALLATION INSTRUCTIONS

KIT# 523179-5

10/29/19
KS

ROADMASTER, Inc. 6110 NE 127th Ave. Vancouver, WA 98682 360-896-0407 fax 360-735-9300 www.roadmasterinc.com

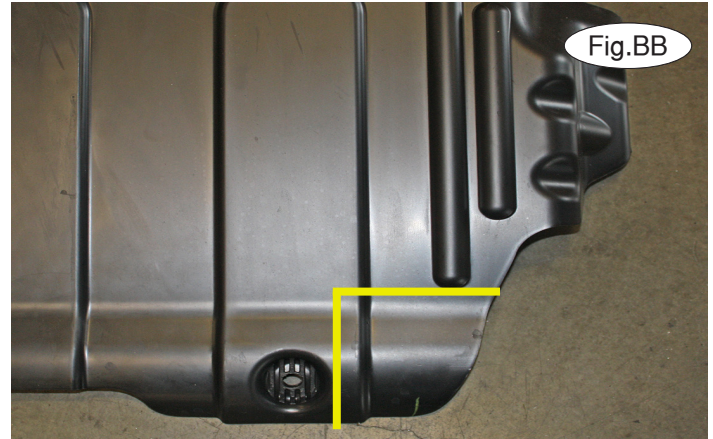
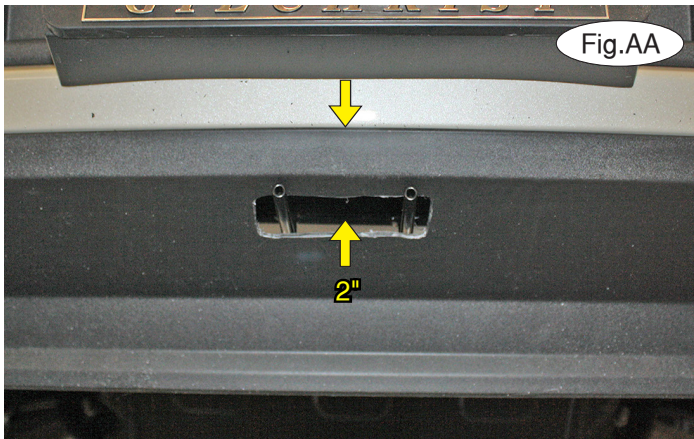

17. Looking straight on at the fascia, measure down 2" from the seam of the fascia, on center of the fascia, and trim a 1" x 4" rectangle to allow clearance for the wiring prongs (Fig.AA). Contour all holes as much as necessary to reach the desired level of detail.

18. Trim each front corner of the skid plate as shown in Figure BB to allow clearance for the rear braces.

19. Reverse steps 1 through 7 to reinstall the fascia and skid plate. **Note: ensure that the fascia wiring harness is secured well clear of the ACC unit when reinstalling the fascia. Otherwise, you may experience issues with the ACC unit.**

20. On each side, insert the removable front arm into the front receiver 90 degrees from its final towing position, depressing the spring-loaded pin against the receiver. Twist back 90 degrees until the spring-loaded pin snaps into place in the notch on the receiver, locking the arm into its final towing position. **Please note: it is the owner's responsibility to ensure the locking of the pins before towing. Otherwise, failure of the towing system will result.**

21. Install the tow bar to the mounting bracket according to the manufacturer's instructions.

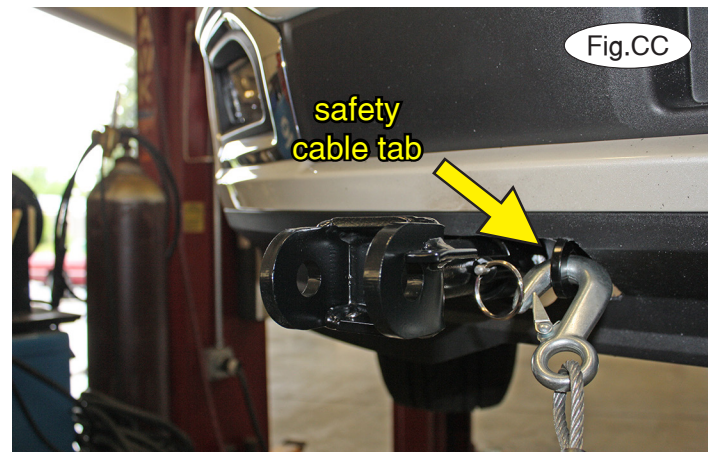

IMPORTANT!

Safety cables are required by law. When towing, connect safety cables to the safety cable tabs illustrated on the first page and in Figure CC. Make certain there is adequate slack in the cables to allow a full turning radius; otherwise, damage will result. If necessary, longer cables or cable extensions are available.



BASEPLATE KIT INSTALLATION INSTRUCTIONS

KIT# 523179-5

10/29/19
KS

ROADMASTER, Inc. 6110 NE 127th Ave. Vancouver, WA 98682 360-896-0407 fax 360-735-9300 www.roadmasterinc.com

Three options for attaching the wiring plug to the main receiver brace

For six-wire plugs: use the two supplied 3/4" self-tapping screws to attach the electrical plug directly to the rods on the front of the main receiver brace.

For four-wire round plugs: attach to the plug mounting plate and then use the two supplied 3/4" self-tapping screws to attach the mounting plate to the rods on the front of the main receiver brace.

For four-wire flat plugs: place the plug through the mounting plug plate, and then secure it using the supplied zip tie on the front of the plug (Fig.DD). Use the two supplied 3/4" self-tapping screws to attach the mounting plate to the rods on the front of the main receiver brace.

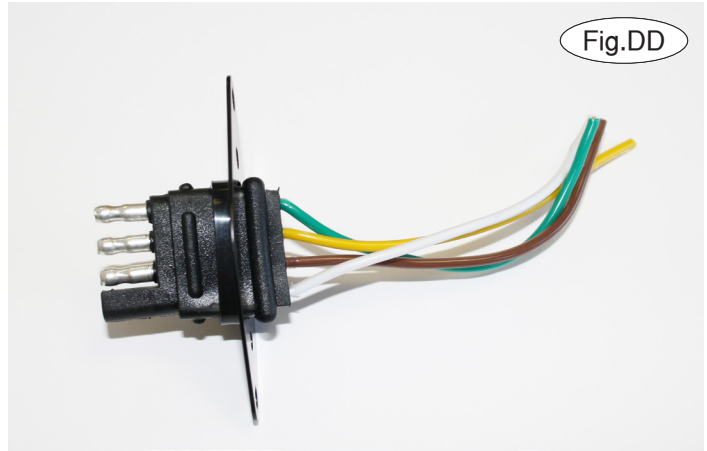

Fig.DD

BOLT TORQUE REQUIREMENTS

Note: The torque values represented below are intended as general guidelines. Torque requirements for specific applications may vary. Roadmaster does not warrant this information to be accurate for all applications and disclaims all liability for any claims or damages which may result from its use.

STANDARD BOLTS

Thread Size	Grade	Torque
5/16.....	5.....	13 ft./lb.
3/8.....	5.....	23 ft./lb.
7/16.....	5.....	37 ft./lb.
1/2.....	5.....	56 ft./lb.
5/8.....	5.....	150 ft./lb.

METRIC BOLTS

Thread Size	Grade	Plated / Unplated
8mm-1.0	8.8	20 ft./lb. 18 ft./lb.
8mm-1.25	8.8	19 ft./lb. 18 ft./lb.
10mm-1.25	8.8	38 ft./lb. 36 ft./lb.
10mm-1.5	8.8	37 ft./lb. 35 ft./lb.

METRIC BOLTS

Thread Size	Grade	Plated / Unplated
12mm-1.25	8.8	70 ft./lb. 65 ft./lb.
12mm-1.5	8.8	66 ft./lb. 61 ft./lb.
12mm-1.75	8.8	65 ft./lb. 60 ft./lb.
14mm-2.0	8.8	104 ft./lb. 97 ft./lb.

All illustrations and specifications contained herein are based on the latest information available at the time of publication approval. ROADMASTER, INC. reserves the right to make changes at any time without notice in material, specification and models or to discontinue models.