



# BASEPLATE KIT INSTALLATION INSTRUCTIONS

**KIT# 523186-5**

04/26/18  
KS

ROADMASTER, Inc. 6110 NE 127th Ave. Vancouver, WA 98682 360-896-0407 fax 360-735-9300 www.roadmasterinc.com

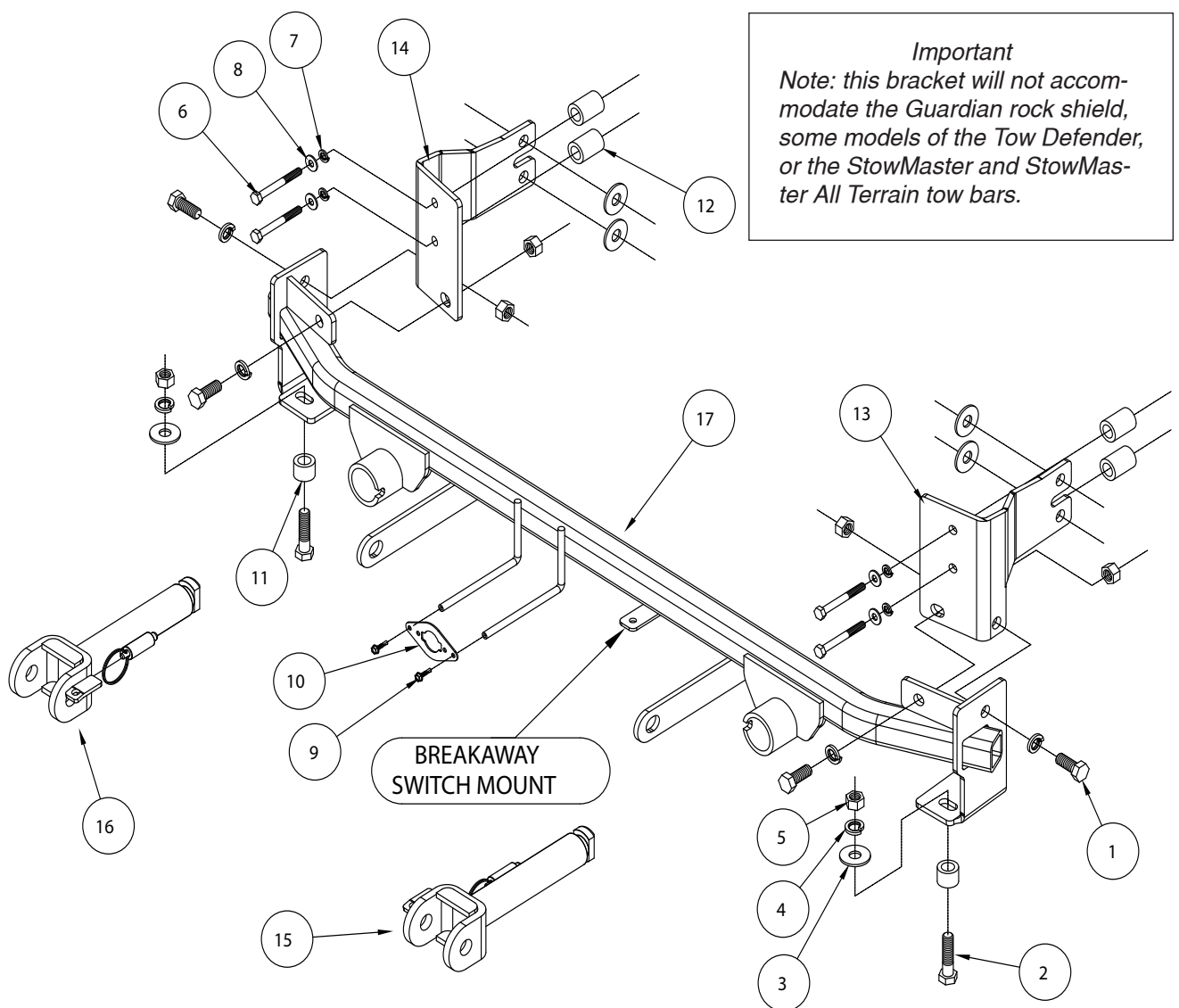

ITEM	QTY	NAME	PART #
1.....	4.....	1/2" x 1 1/4" BOLT .....	350094-00
2.....	2.....	1/2" x 2" BOLT .....	350097-00
3.....	6.....	1/2" FLAT WASHER .....	350308-00
4.....	6.....	1/2" LOCK WASHER.....	350309-00
5.....	6.....	1/2" NUT .....	350258-00
6.....	4.....	8mm x 1.25 x 70mm.....	356007-70
7.....	4.....	8mm LOCK WASHER.....	355705-00
8.....	4.....	5/16" FLAT WASHER .....	350302-00
9.....	2.....	#10 x 3/4" SELF DRILLING SCREW .....	350247-35
10.....	1.....	WIRE PLUG PLATE .....	A-003801
11.....	2.....	1" O.D. x 0.188 WALL x 3/4" TUBE SPACER .....	A-000112
12.....	4.....	1" O.D. x 0.188 WALL x 1 3/8" TUBE SPACER .....	A-003033
13.....	1.....	DRIVER SIDE UPPER MOUNTING PLATE .....	B-003163
14.....	1.....	PASSENGER SIDE UPPER MOUNTING PLATE.....	B-003164
15.....	1.....	DRIVER SIDE ARM .....	C-002383
16.....	1.....	PASSENGER SIDE ARM.....	C-002384
17.....	1.....	MAIN RECEIVER BRACE.....	C-003055



# BASEPLATE KIT INSTALLATION INSTRUCTIONS

**KIT# 523186-5**

04/26/18  
KS

ROADMASTER, Inc. 6110 NE 127th Ave. Vancouver, WA 98682 360-896-0407 fax 360-735-9300 www.roadmasterinc.com

This is one of our direct-connect series brackets, which allows the visible front portion of the bracket to be easily removed from the front of the vehicle (Fig.A and Fig.B). The bracket consists of a main receiver brace, two removable front braces, and a hardware pack.

The main receiver brace mounts to the sub-frame and rear support braces. The rear braces mount to the bumper core and frame rails. The removable front braces install in the main receiver brace.

Before starting the installation, lay out the kit components in order, as they will be used. This will give you a visual idea of how the components work, and will also confirm that everything is present and accounted for.



**IMPORTANT:** All baseplates **must** be assembled with all the bolts left loose for final adjustment and positioning (before tightening) unless otherwise instructed. All bolts **must** be torqued for proper strength. If more than one bolt is used per fastening point, the diagram may only show one. Use flat washers over all slotted holes and lock washers on all fasteners.

## WARNING

Failure to heed these warnings or follow the installation instructions may result in a voided warranty, loss of towed vehicle, personal injury or death.

- Do not weld or modify this baseplate or its components. Welding or modification will void the warranty.
- Do not use this document as a basis to design/fabricate a baseplate, as it may not show all parts or structural components.
- We strongly recommend professional installation.
- If the towed vehicle has been in an accident, it must be properly repaired before attaching the baseplate. Do not install the baseplate if any structural frame damage is found.
- The installer must use all bolts and parts supplied. If running changes were made by the vehicle manufacturer after this kit was designed, some bolts or other fasteners may no longer be the correct size. It is the installer's responsibility to verify this kit is securely fastened to the vehicle.
- Use Loctite® Red on all bolts used to secure this baseplate. Torque all bolts to the specifications found at the end of these instructions. Do not over-torque the bolts or failure may occur.
- The installer must inspect the baseplate to ensure adequate clearance, particularly around hoses, air conditioner lines, radiators, etc. or non-warranty failure may result.
- Roadmaster manufactures many styles of baseplates. If your baseplate has removable arms, they must be removed before driving the vehicle, unless the arms can be pinned or padlocked in place. If not secured, the arms could vibrate out.
- Some motorhome chassis have such a tight turning radius that you can damage your motorhome, towed vehicle, tow bar or baseplate while turning sharply. Before getting on the road, test your turning radius in an empty parking lot. Turning too sharply could result in non-warranty damage to your towing system, motorhome and/or towed vehicle.
- Do not back up with the towed vehicle attached or non-warranty damage will occur to your towing system or vehicles.
- The safety cables must connect the towing vehicle to the towed vehicle frame to frame, with the cables crossed, with enough slack for sharp turns. See cable instructions for proper routing. Failure to do so will result in non-warranty damage and/or the loss of the towed vehicle.
- This kit is designed for use with ROADMASTER tow bars and ROADMASTER adapters only. Using this kit with other brands, without an approved ROADMASTER adapter, may result in non-warranty damage or injury.
- Receiver extensions and out-of-level towing situations of 3 inches or more. This can cause the system to swing much higher and lower, causing excessive strain on the tow bar, baseplate and frame. That can cause the towing system to fail, causing property damage, personal injury or even death. If you must use a receiver extension or drop hitch to tow, it will reduce your receiver's weight capacity by 1/3 to avoid damaging your system. Never use more than one extension and/or drop hitch, as this will void your warranty.
- Every 3,000 miles, the owner must inspect all mounting points for cracks or fatigue, and check the fasteners for proper torque, according to the bolt torque requirements chart on the last page of these instructions.
- The owner must follow the vehicle manufacturer's instructions to prepare the vehicle for towing. Failure to do so may cause severe damage to the vehicle.
- This baseplate is only warranted for the original installation. Installing a used baseplate on another vehicle is not recommended and will void the warranty.



# BASEPLATE KIT INSTALLATION INSTRUCTIONS

**KIT# 523186-5**

04/26/18  
KS

ROADMASTER, Inc. 6110 NE 127th Ave. Vancouver, WA 98682 360-896-0407 fax 360-735-9300 www.roadmasterinc.com

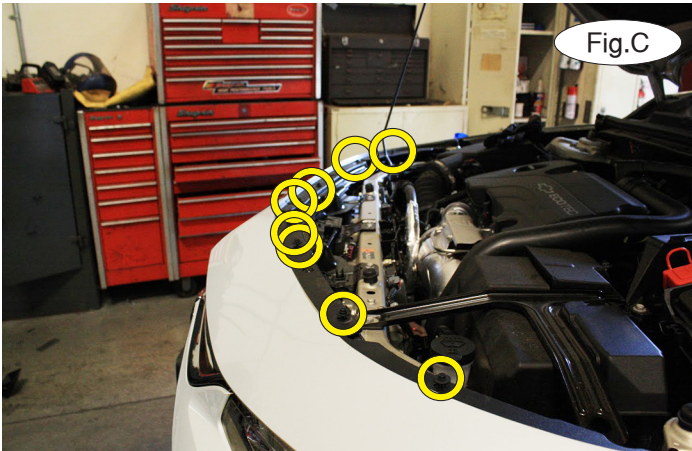

1. **Important:** please use all supplied bolts and parts and read all instructions carefully before beginning this installation. The majority of questions you may have can be answered within the text, and proper installation will ensure safe and secure travel. Now, begin the installation. Remove eight 7mm (head) screws attaching the top of the fascia to the core support (Fig.C). *Note:* due to manufacturing variances, the fasteners may be T15 Torx instead.

2. On each side, remove one 10mm (head) bolt attaching the upper corner of the fascia to the fender, just above the headlight (Fig.D). Then, remove the retaining clip and set it aside (Fig.E).

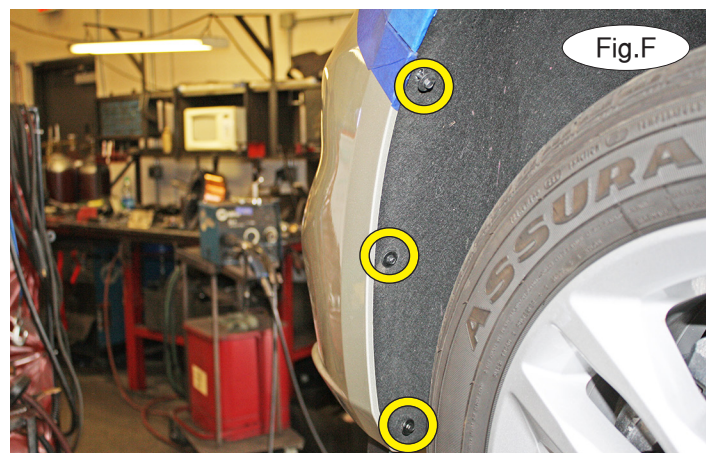

3. On each side, remove three 7mm (head) screws attaching the fender liner to the fascia (Fig.F). *Note:* due to manufacturing variances, the fasteners may be T15 Torx instead.

4. On each side, pull back the fender liner and remove one 7mm (head) bolt attaching the corner of the fascia to the fender (Fig.G).

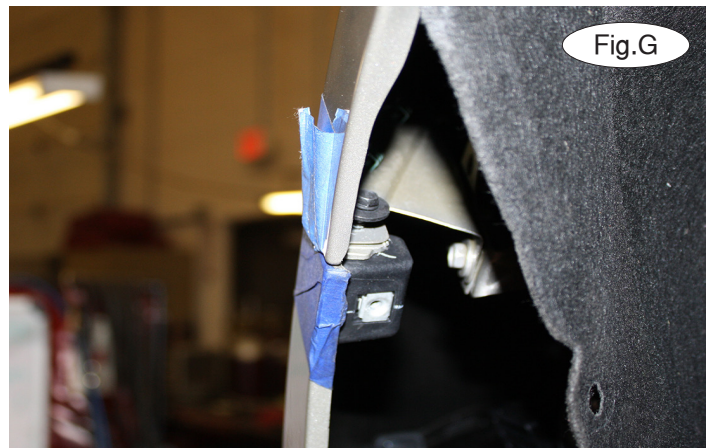



# BASEPLATE KIT INSTALLATION INSTRUCTIONS

**KIT# 523186-5**

04/26/18  
KS

ROADMASTER, Inc. 6110 NE 127th Ave. Vancouver, WA 98682 360-896-0407 fax 360-735-9300 www.roadmasterinc.com

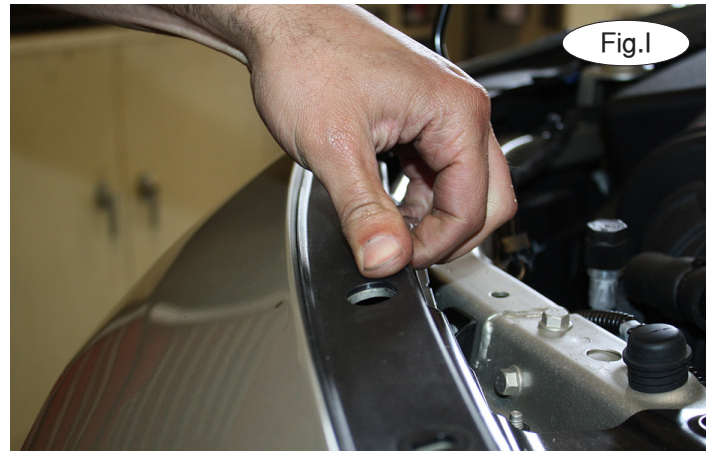
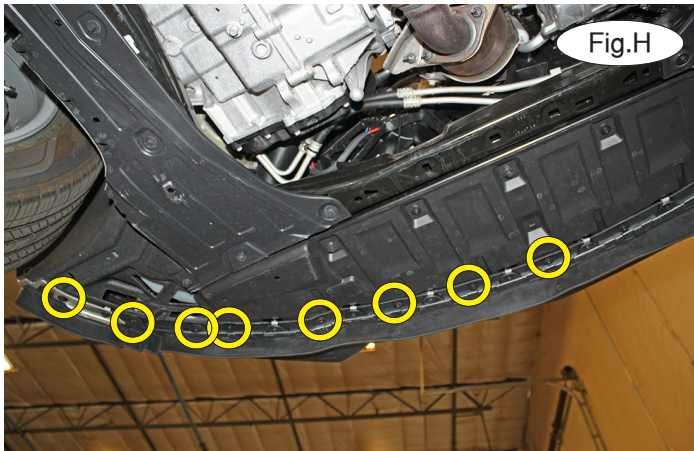

5. On each side, remove seven T15 Torx bolts and one T15 Torx bolt in the middle attaching the splash shielding to the fascia (Fig.H). *Note:* due to manufacturing variances, the fasteners may be 7mm (head) bolts instead.

6. On each side, pull up on the top of the fascia to release it from the retaining pin (Fig.I).

7. On each side, release the locking strip attaching the fender to fascia above and below the headlight (Fig.J). Disconnect any electrical connectors and then set the fascia aside. Remove the foam shock absorption pad and set it aside for now.



8. On each side, remove the headlight by removing four 7mm (head) screws attaching the headlight to the frame (Fig.K and Fig.L).

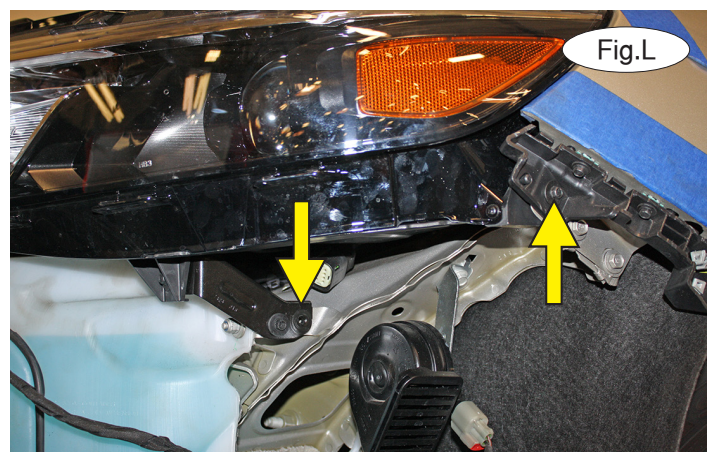



# BASEPLATE KIT INSTALLATION INSTRUCTIONS

**KIT# 523186-5**

04/26/18  
KS

ROADMASTER, Inc. 6110 NE 127th Ave. Vancouver, WA 98682 360-896-0407 fax 360-735-9300 www.roadmasterinc.com

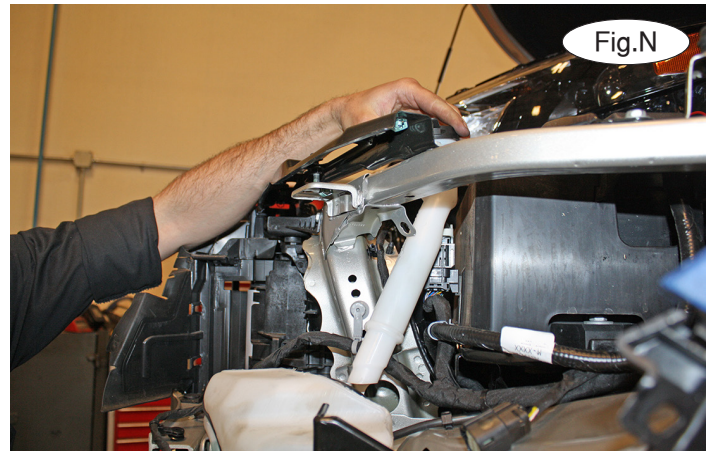

9. Disconnect any electrical connectors, and pull up on the plastic tab to release it (Fig.M). Now, set the headlight aside.
10. On the driver's side only, pull straight out and up to disconnect the filler neck from the washer bottle (Fig.N).

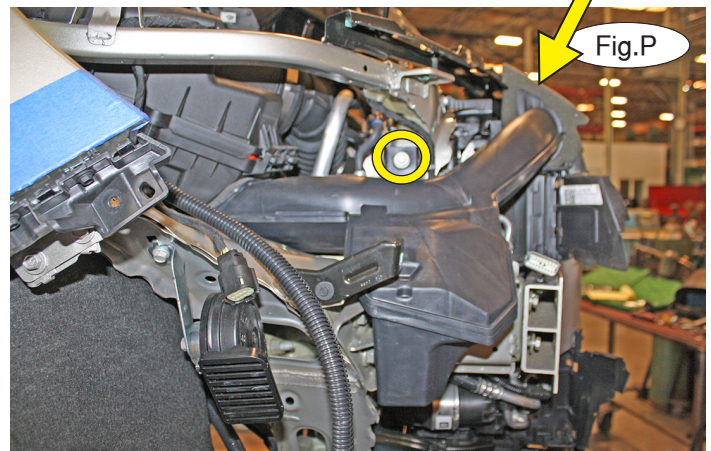
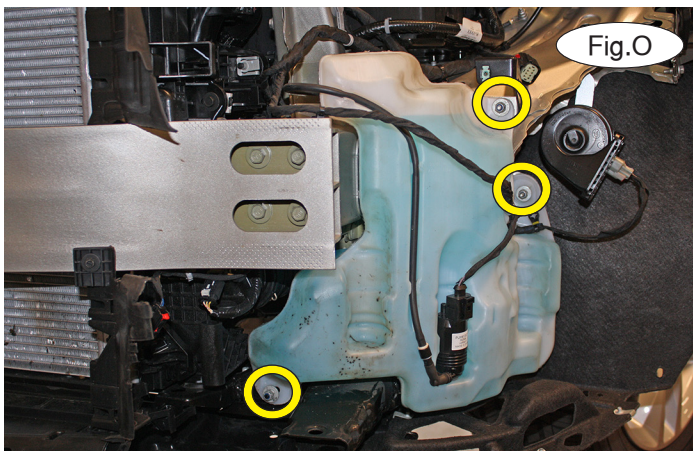

11. On the driver's side only, remove three 10mm (head) nuts attaching the washer bottle to the frame (Fig.O). Secure the washer bottle away from the frame or drain it and set it aside for now.

12. Remove one 10mm (head) screw and one plastic fastener attaching the air ducting to the frame (Fig.P).

13. Remove one 7mm (head) screw attaching the vertical section of the air dam to the bumper core and then remove one plastic fastener from the bottom of the air dam (Fig.Q).

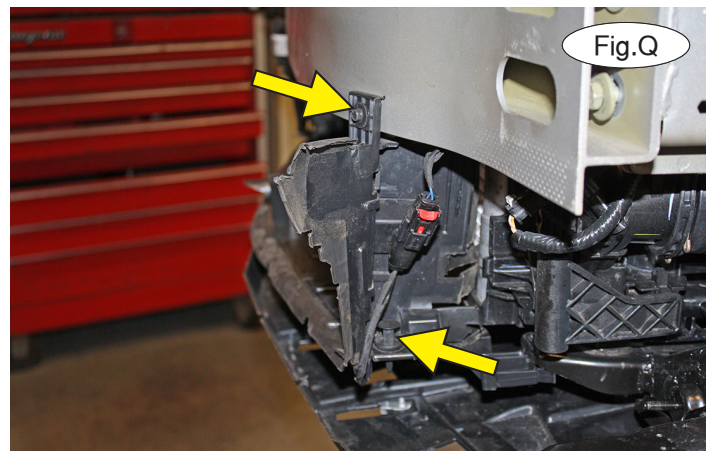



# BASEPLATE KIT INSTALLATION INSTRUCTIONS

**KIT# 523186-5**

04/26/18  
KS

ROADMASTER, Inc. 6110 NE 127th Ave. Vancouver, WA 98682 360-896-0407 fax 360-735-9300 www.roadmasterinc.com

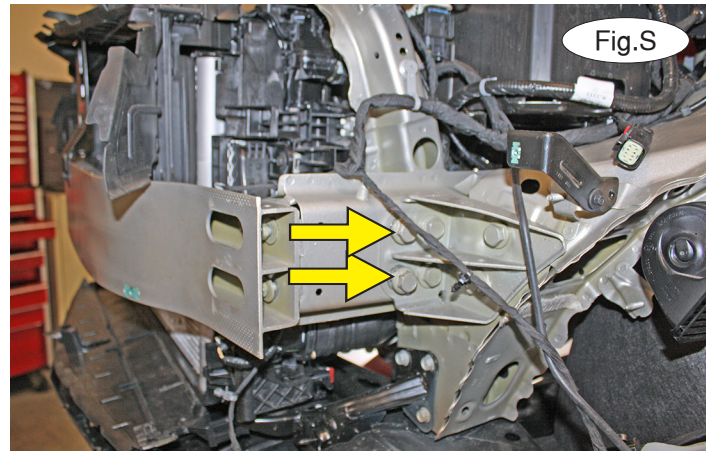
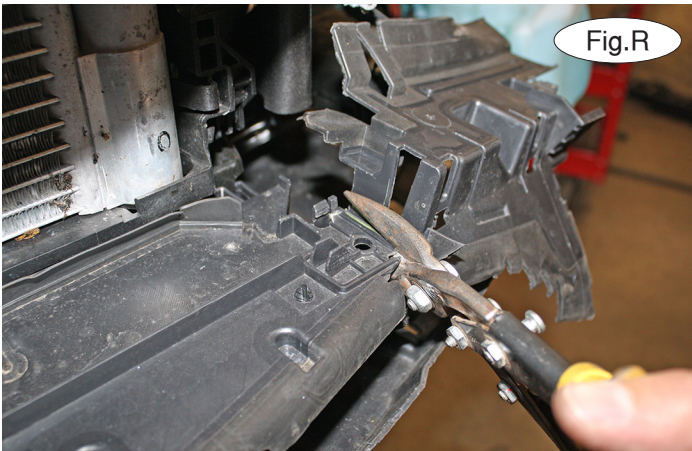

14. On each side, lay the air dam flat and trim it as shown in Figure R to allow clearance for the main receiver brace.
15. On each side, remove the two forwardmost 18mm (head) bolts attaching the bumper core to the frame rail (Fig.S).
16. On each side, remove the two outermost 13mm (head) bolts attaching the bumper core to the frame rail (Fig.T).
17. On each side, use a ½" drill bit or a die grinder to enlarge the existing hole in the framing as showing in Figure U.

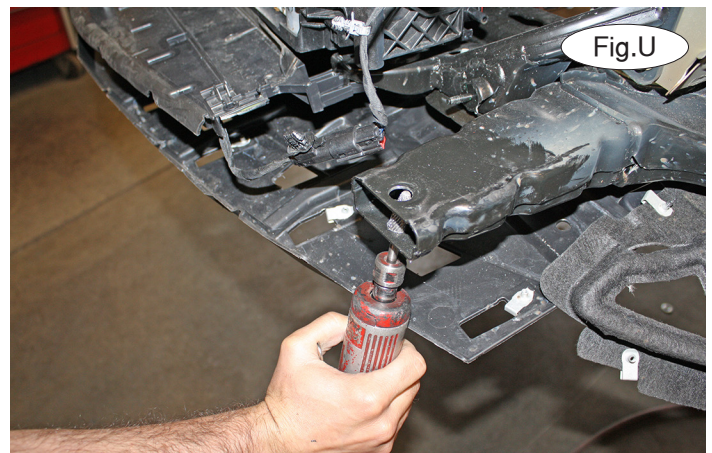
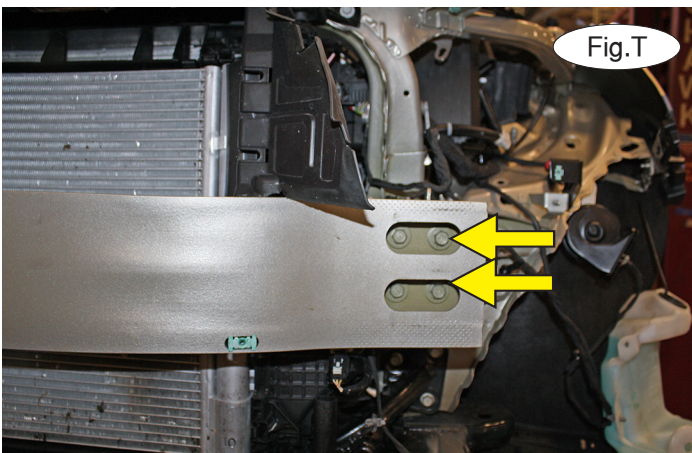

18. On each side, place the rear support brace over the bumper core and one of the supplied ½" flat washers between the frame and the support, and then replace the 18mm (head) bolts you removed in step 15. Turn the bolts a couple of threads only. Then, place one of the supplied 1" x .188 wall x 1 3/8" pipe spacers inside the frame, behind the front mounting points and bolt through the rear support brace, pipe spacers and into the bumper core using two of the supplied 8mm x 1.25 x 70mm bolts, 8mm lock washers and 8mm nuts (Fig.V).

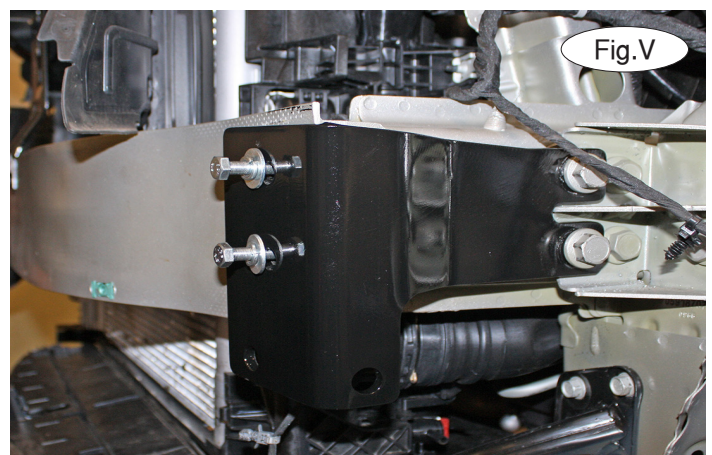



# BASEPLATE KIT INSTALLATION INSTRUCTIONS

**KIT# 523186-5**

04/26/18  
KS

ROADMASTER, Inc. 6110 NE 127th Ave. Vancouver, WA 98682 360-896-0407 fax 360-735-9300 www.roadmasterinc.com

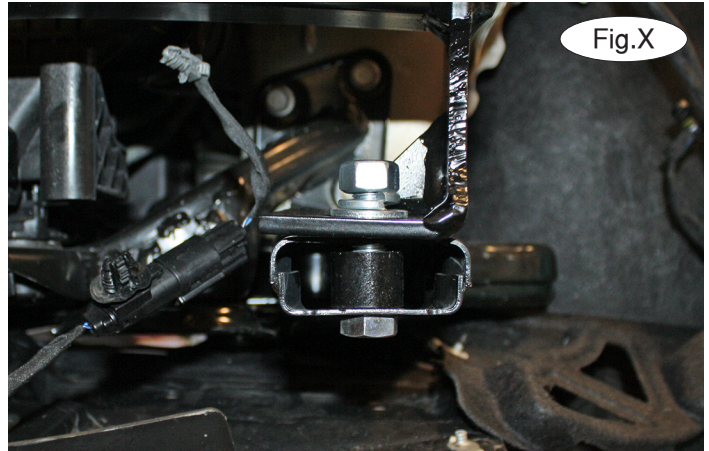
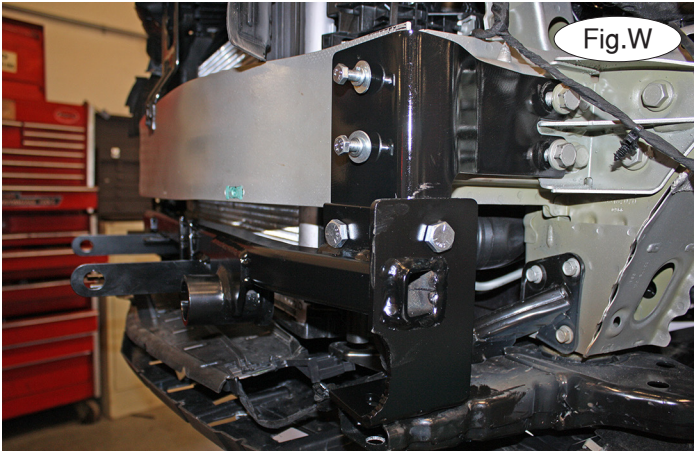

19. Now, place the main receiver brace over the rear support braces and on each side, bolt it to the brace using the two supplied  $\frac{1}{2}$ " x  $1\frac{1}{4}$ " bolts,  $\frac{1}{2}$ " lock washers and  $\frac{1}{2}$ " nuts (Fig.W).

20. On each side, place one of the supplied 1" x .188 wall x  $\frac{3}{4}$ " pipe spacers inside the framing and then bolt up through the frame, pipe spacer and the main receiver brace using the supplied  $\frac{1}{2}$ " x 2" bolt,  $\frac{1}{2}$ " flat washer, lock washer and nut (Fig.X).



21. Tighten all bolts to the bolt torque requirements found at the end of these instructions. *Note:* use Loctite® Red on all nuts and bolts.

22. Reinstall the washer bottle, reversing step 11. Trim the foam shock absorption pad as shown in Figure Y and then reinstall it. Now, reinstall the fascia, reversing steps 1 through 7.

23. *Note: the following four images are for illustration purposes only, as your specific application may be slightly different.*

The spring-loaded pin on the removable arm snaps into a notch on the receiver, locking the removable arm into its final towing position. Before inserting each arm into the receiver, verify that the spring is working by ensuring that the spring-loaded pin moves easily back and forth within the barrel when pulled and that it can be pulled flush with the face of the barrel (Fig.Z and Fig.AA).





# BASEPLATE KIT INSTALLATION INSTRUCTIONS

**KIT# 523186-5**

04/26/18  
KS

ROADMASTER, Inc. 6110 NE 127th Ave. Vancouver, WA 98682 360-896-0407 fax 360-735-9300 www.roadmasterinc.com

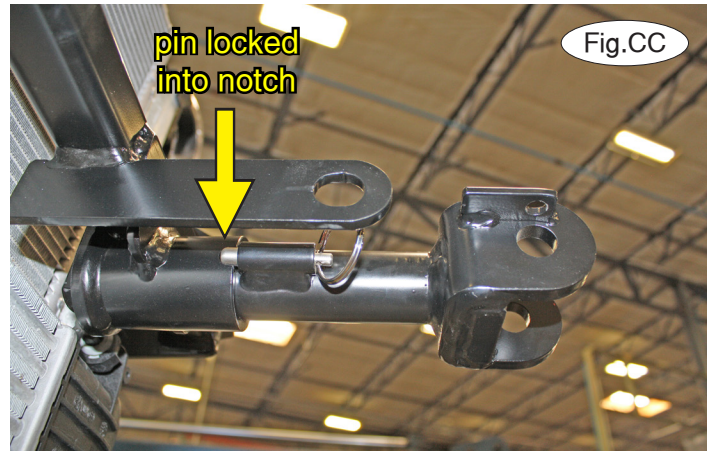
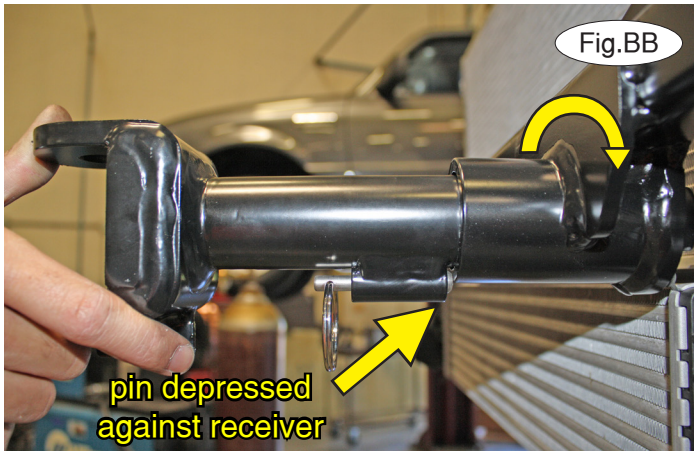

24. On each side, insert the removable front bracket arm into the front receiver 90 degrees from its final towing position, depressing the spring-loaded pin against the receiver (Fig.BB). Now, twist back 90 degrees until the spring-loaded pin snaps into place in the notch on the receiver, locking the arm into place in its final towing position (Fig.CC).

**Please note: it is the owner's responsibility to ensure the locking of the pins before towing. Otherwise, failure of the towing system will result.**

25. Install the tow bar to the mounting bracket according to the manufacturer's instructions.

### **IMPORTANT!**

**Safety cables are required by law. When towing, connect safety cables to the safety cable tabs illustrated in Figure DD. Make certain there is adequate slack in the cables to allow a full turning radius; otherwise, damage will result. If necessary, longer cables or cable extensions are available.**

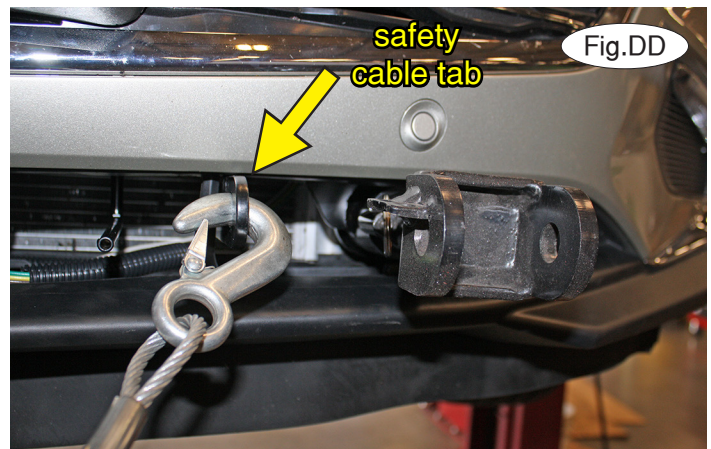



# BASEPLATE KIT INSTALLATION INSTRUCTIONS

**KIT# 523186-5**

04/26/18  
KS

ROADMASTER, Inc. 6110 NE 127th Ave. Vancouver, WA 98682 360-896-0407 fax 360-735-9300 www.roadmasterinc.com

## Three options for attaching the wiring plug to the main receiver brace

**For six-wire plugs:** use the two supplied 3/4" self-tapping screws to attach the electrical plug directly to the rods on the front of the main receiver brace.

**For four-wire round plugs:** attach to the plug mounting plate and then use the two supplied 3/4" self-tapping screws to attach the mounting plate to the rods on the front of the main receiver brace.

**For four-wire flat plugs:** place the plug through the mounting plug plate, and then secure it using the supplied zip tie on the front of the plug (Fig.EE). Use the two supplied 3/4" self-tapping screws to attach the mounting plate to the rods on the front of the main receiver brace.

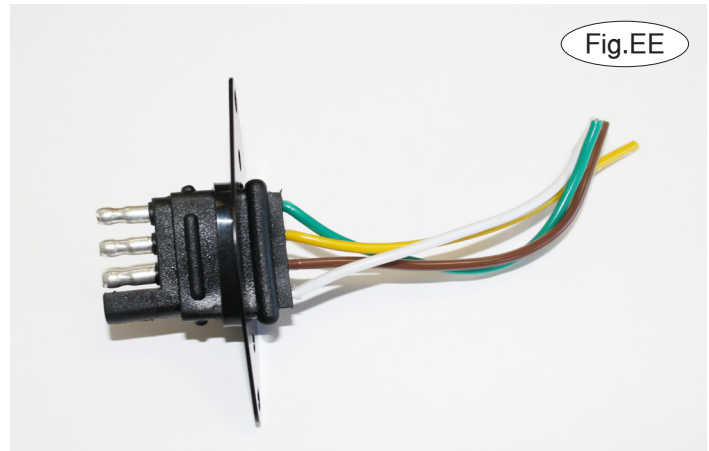

## BOLT TORQUE REQUIREMENTS

Note: The torque values represented below are intended as general guidelines. Torque requirements for specific applications may vary. Roadmaster does not warrant this information to be accurate for all applications and disclaims all liability for any claims or damages which may result from its use.

### STANDARD BOLTS

Thread Size	Grade	Torque
5/16.....	5.....	13 ft./lb.
3/8.....	5.....	23 ft./lb.
7/16.....	5.....	37 ft./lb.
1/2.....	5.....	56 ft./lb.
5/8.....	5.....	150 ft./lb.

### METRIC BOLTS

Thread Size	Grade	Plated / Unplated
8mm-1.0.....	8.8.....	20 ft./lb. 18 ft./lb.
8mm-1.25.....	8.8.....	19 ft./lb. 18 ft./lb.
10mm-1.25.....	8.8.....	38 ft./lb. 36 ft./lb.
10mm-1.5.....	8.8.....	37 ft./lb. 35 ft./lb.

### METRIC BOLTS

Thread Size	Grade	Plated / Unplated
12mm-1.25.....	8.8.....	70 ft./lb. 65 ft./lb.
12mm-1.5.....	8.8.....	66 ft./lb. 61 ft./lb.
12mm-1.75.....	8.8.....	65 ft./lb. 60 ft./lb.
14mm-2.0.....	8.8.....	104 ft./lb. 97 ft./lb.

All illustrations and specifications contained herein are based on the latest information available at the time of publication approval. ROADMASTER, INC. reserves the right to make changes at any time without notice in material, specification and models or to discontinue models.