



# BASEPLATE KIT INSTALLATION INSTRUCTIONS

**KIT# 523206-4**

05/07/21  
KS

ROADMASTER, Inc. 6110 NE 127th Ave. Vancouver, WA 98682 360-896-0407 fax 360-735-9300 www.roadmasterinc.com

## Recommended Tools

Ratchet	Flathead screwdriver
7mm, 13mm, 15mm, 17mm sockets	T15 Torx screwdriver or bit
3/4" wrench	Needlenose pliers
3/4" socket	

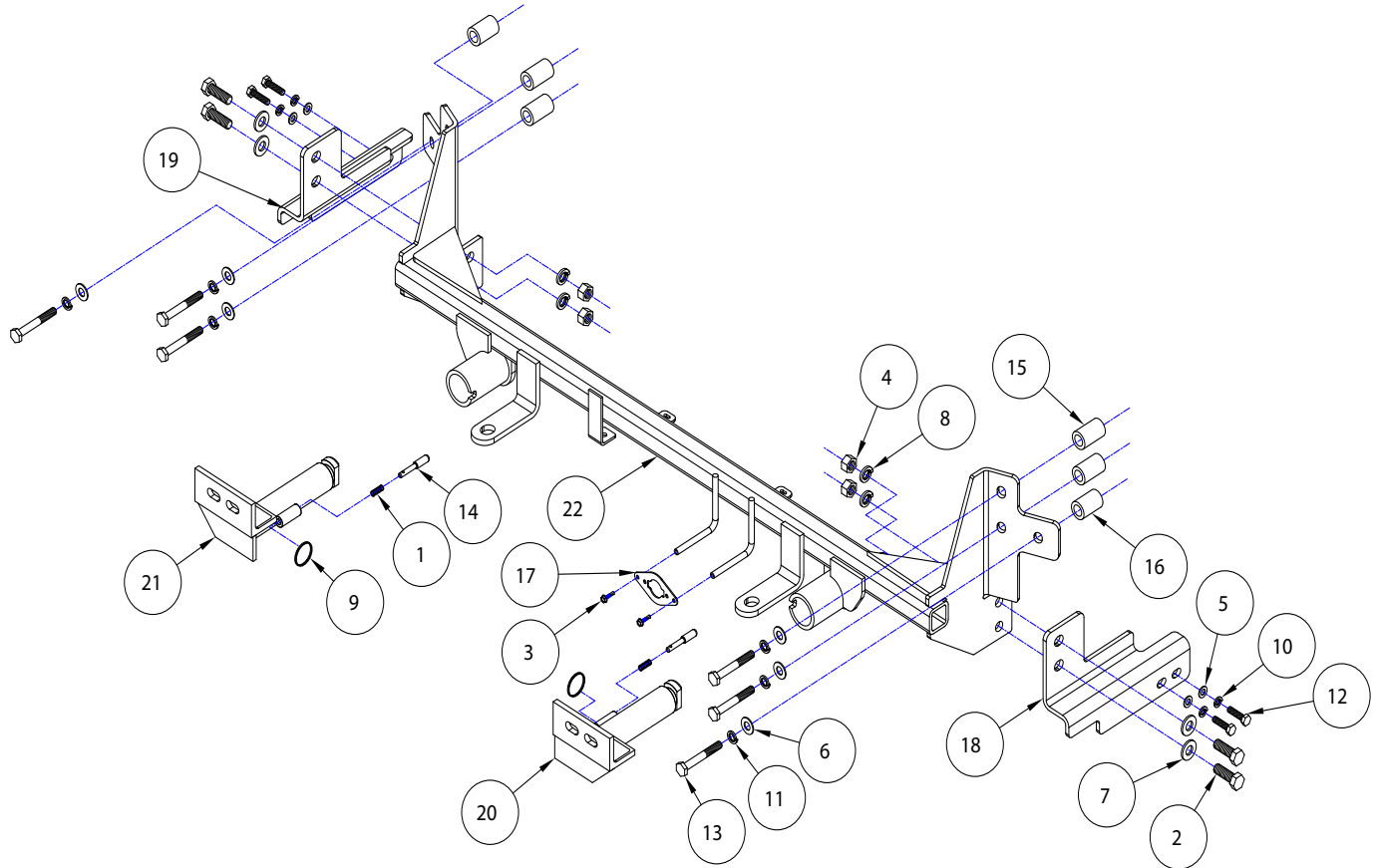

ITEM	QTY	DESCRIPTION	MATERIAL#
1	2	SPRING	200148-00
2	4	1/2" x 1 1/2" BOLT	350095-00
3	2	#10 x 3/4" SELF DRILLING SCREW	350247-35
4	4	1/2" HEX NUT	350258-00
5	4	3/8" FLAT WASHER	350304-00
6	6	7/16" FLAT WASHERS	350306-00
7	4	1/2" SAE WASHER	350308-20
8	4	1/2" LOCK WASHER	350309-00
9	2	RING	350520-00
10	4	M8 LOCK WASHER	355705-00
11	6	M10 LOCK WASHER	355715-00
12	4	M8 x 1.25 x 30 mm BOLT	356001-00
13	6	M10 x 1.5 x 75 mm BOLT	356114-00
14	2	LOCK PIN	A000008
15	4	1" O.D. x 0.188" WALL x 1 5/8" TUBE SPACER	A001442
16	2	1" O.D. x 0.188" WALL x 1 1/2" TUBE SPACER	A002898
17	1	WIRE PLUG PLATE	A003801
18	1	DRIVER SIDE BRACE	B003888
19	1	PASSENGER SIDE BRACE	B003889
20	1	DRIVER SIDE ARM	C002540
21	1	PASSENGER SIDE ARM	C002541
22	1	MAIN RECEIVER	C003549
23	6	4" ZIP TIE	300140-04



# BASEPLATE KIT INSTALLATION INSTRUCTIONS

**KIT# 523206-4**

05/07/21  
KS

ROADMASTER, Inc. 6110 NE 127th Ave. Vancouver, WA 98682 360-896-0407 fax 360-735-9300 www.roadmasterinc.com

This is one of our crossbar-style baseplates, which allows the visible front portion of the bracket to be easily removed from the front of the vehicle (Fig.A and Fig.B).

The baseplate mounts to the side-specific braces and the frame of the vehicle and consists of two side-specific braces, two removable front braces, and a hardware pack.

Before starting the installation, lay out the kit components in order, as they will be used. This will give you a visual idea of how the components work, and will also confirm that everything is present and accounted for.



**IMPORTANT:** All baseplates **must** be assembled with all the bolts left loose for final adjustment and positioning (before tightening) unless otherwise instructed. All bolts **must** be torqued for proper strength. If more than one bolt is used per fastening point, the diagram may only show one. Use flat washers over all slotted holes and lock washers on all fasteners.

## WARNING

Failure to heed these warnings or follow the installation instructions may result in a voided warranty, loss of towed vehicle, personal injury or death.

- Do not weld or modify this baseplate or its components. Welding or modification will void the warranty.
- Do not use this document as a basis to design/fabricate a baseplate, as it may not show all parts or structural components.
- We strongly recommend professional installation.
- If the towed vehicle has been in an accident, it must be properly repaired before attaching the baseplate. Do not install the baseplate if any structural frame damage is found.
- The installer must use all bolts and parts supplied. If running changes were made by the vehicle manufacturer after this kit was designed, some bolts or other fasteners may no longer be the correct size. It is the installer's responsibility to verify this kit is securely fastened to the vehicle.
- Use Loctite® Red on all bolts used to secure this baseplate. Torque all bolts to the specifications found at the end of these instructions. Do not over-torque the bolts or failure may occur.
- The installer must inspect the baseplate to ensure adequate clearance, particularly around hoses, air conditioner lines, radiators, etc. or non-warranty failure may result.
- Roadmaster manufactures many styles of baseplates. If your baseplate has removable arms, they must be removed before driving the vehicle, unless the arms can be pinned or padlocked in place. If not secured, the arms could vibrate out.
- Some motorhome chassis have such a tight turning radius that you can damage your motorhome, towed vehicle, tow bar or baseplate while turning sharply. Before getting on the road, test your turning radius in an empty parking lot. Turning too sharply could result in non-warranty damage to your towing system, motorhome and/or towed vehicle.
- Do not back up with the towed vehicle attached or non-warranty damage will occur to your towing system or vehicles.
- The safety cables must connect the towing vehicle to the towed vehicle frame to frame, with the cables crossed, with enough slack for sharp turns. See cable instructions for proper routing. Failure to do so will result in non-warranty damage and/or the loss of the towed vehicle.
- This kit is designed for use with ROADMASTER tow bars and ROADMASTER adapters only. Using this kit with other brands, without an approved ROADMASTER adapter, may result in non-warranty damage or injury.
- Receiver extensions and out-of-level towing situations of 3 inches or more. This can cause the system to swing much higher and lower, causing excessive strain on the tow bar, baseplate and frame. That can cause the towing system to fail, causing property damage, personal injury or even death. If you must use a receiver extension or drop hitch to tow, it will reduce your receiver's weight capacity by 1/3 to avoid damaging your system. Never use more than one extension and/or drop hitch, as this will void your warranty.
- Every 3,000 miles, the owner must inspect all mounting points for cracks or fatigue, and check the fasteners for proper torque, according to the bolt torque requirements chart on the last page of these instructions.
- The owner must follow the vehicle manufacturer's instructions to prepare the vehicle for towing. Failure to do so may cause severe damage to the vehicle.
- This baseplate is only warranted for the original installation. Installing a used baseplate on another vehicle is not recommended and will void the warranty.



# BASEPLATE KIT INSTALLATION INSTRUCTIONS

**KIT# 523206-4**

05/07/21  
KS

ROADMASTER, Inc. 6110 NE 127th Ave. Vancouver, WA 98682 360-896-0407 fax 360-735-9300 www.roadmasterinc.com

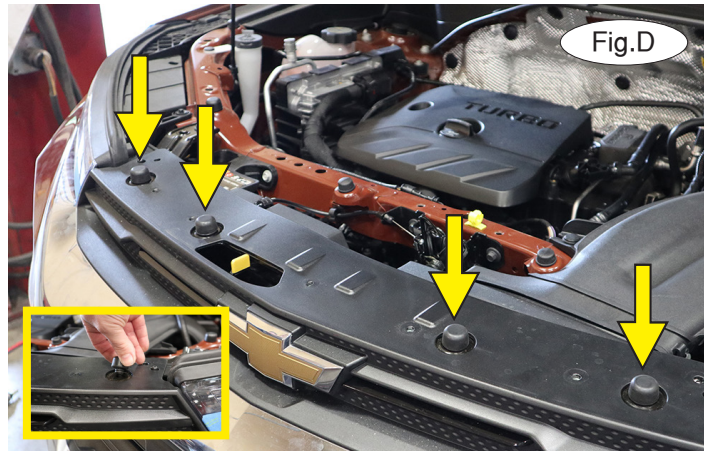
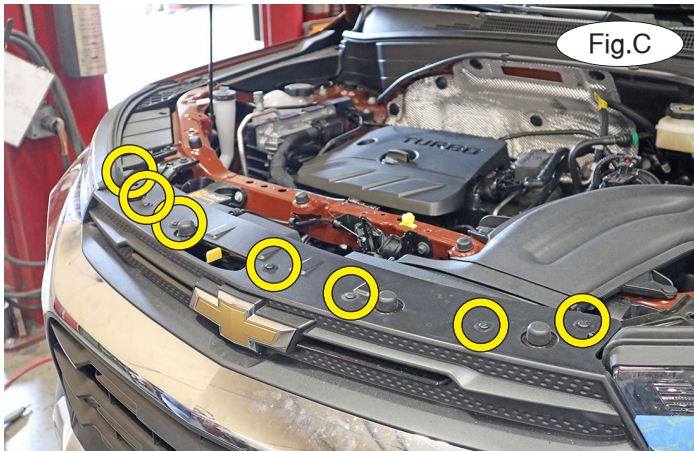

**Important:** please use all supplied bolts and parts and read all instructions carefully before beginning this installation. The majority of questions you may have can be answered within the text, and proper installation will ensure safe and secure travel.

1. Remove seven T15 screws attaching the top of the fascia to the radiator support (Fig.C).
2. Remove the four bump stops (Fig.D – arrows) by gently pulling up and twisting counterclockwise on each one (Fig.D –inset).

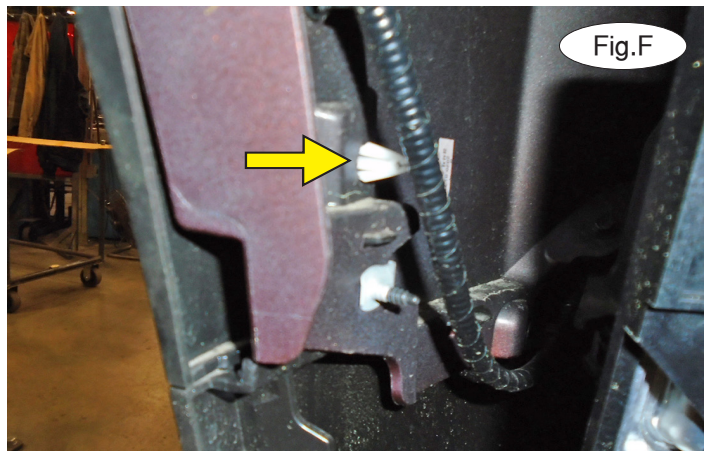

3. On each side, turn the wheel inward and remove four T15 screws attaching the fender liner to the fascia (Fig.E).
4. On each side, pull back the fender liner and use a pair of needlenose pliers or fingers to squeeze each arrowhead clip to release the front half of the fender well trim piece (Fig.F and Fig.G).





# BASEPLATE KIT INSTALLATION INSTRUCTIONS

**KIT# 523206-4**

05/07/21  
KS

ROADMASTER, Inc. 6110 NE 127th Ave. Vancouver, WA 98682 360-896-0407 fax 360-735-9300 www.roadmasterinc.com



5. On each side, use a ratchet and 7mm socket to remove the screw attaching the rear of the fascia to the fender (Fig.H).

6. On each side, remove six T15 screws attaching the fascia to the fender liner and lower radiator support (Fig.I).



7. On each side, simultaneously lift up to release the locking clip on the top of the fascia (Fig.J) while pulling out on the corner to remove it (Fig.K). Unplug any electrical harnesses and carefully set the fascia aside for now. **Note: Do not turn the vehicle on at any point once the fascia has been removed, as it may trigger a check engine light on the dash.**

8. On each side, remove three 7mm screws attaching the lower bumper stiffener to the subframe (Fig.L – circles). Then, remove one plastic fastener on each side (Fig.L – arrow). Set the lower bumper stiffener aside for now.

9. On each side, carefully trim off the upper mount of the lower air dam, as shown in Figure M.

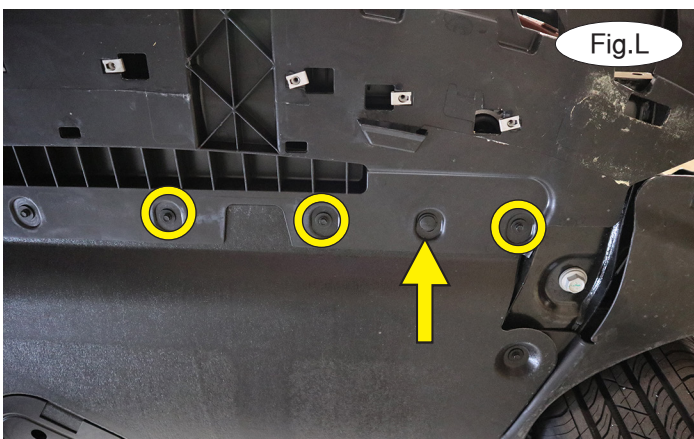



# BASEPLATE KIT INSTALLATION INSTRUCTIONS

**KIT# 523206-4**

05/07/21  
KS

ROADMASTER, Inc. 6110 NE 127th Ave. Vancouver, WA 98682 360-896-0407 fax 360-735-9300 www.roadmasterinc.com

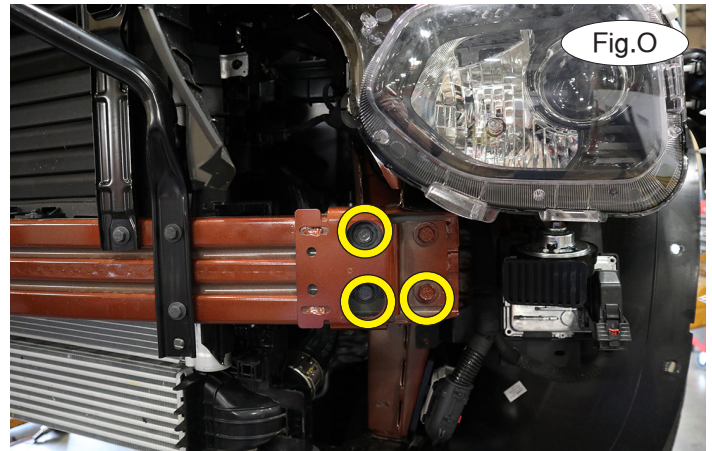

10. On each side, use a flathead screwdriver to push in the retaining clip and pull outward to remove the remaining section of the lower air dam (Fig.N). It will not be replaced.
11. On each side, use a 15mm socket to remove the three indicated bumper core mount bolts (Fig.O). Retain the hardware for replacement in case the baseplate is ever removed.

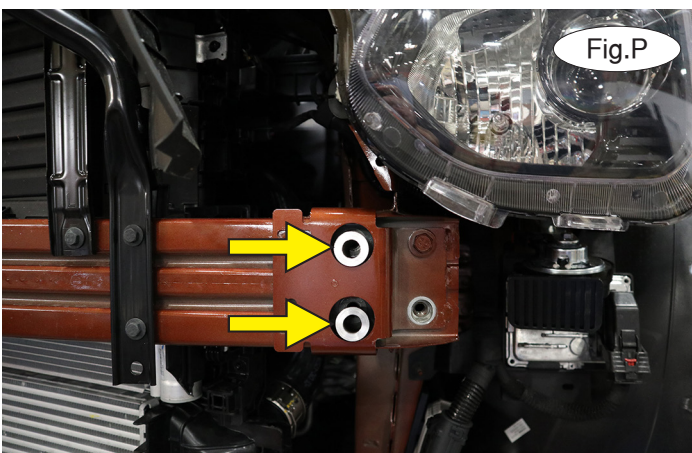

12. **Important! Before proceeding, ensure you measure each pipe spacer before installing it, or the baseplate will not tighten securely.**

On each side, place two 1" O.D. x .188 wall x 1-5/8" pipe spacers over each of the inner bumper core mount holes (Fig.P). Locate the six supplied M10 x 1.5 x 75mm bolts and place an M10 lock washer and 7/16" flat washer over each one. Using a second person for assistance, hold the baseplate in place and, on each side, bolt through the two inner mounts and pipe spacers installed earlier in this step. *Note:* Only turn the bolts until a few threads catch (Fig.Q).

Then, place a 1" O.D. x .188 wall x 1½" pipe spacer between the baseplate and bumper core and bolt through the baseplate and pipe spacer and into the lower outside mount (Fig.R).

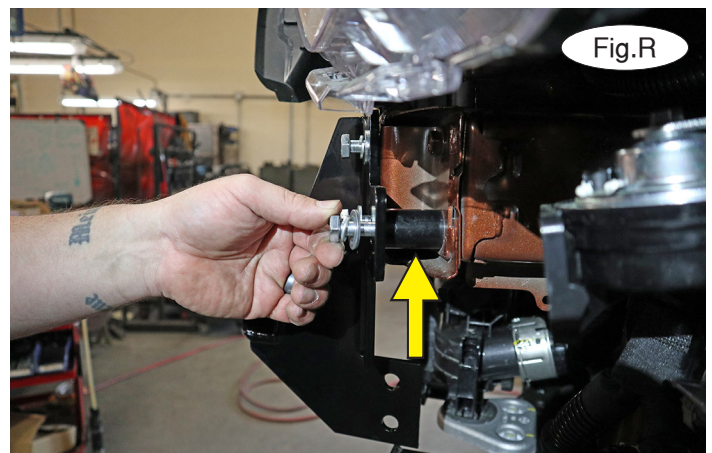

All illustrations and specifications contained herein are based on the latest information available at the time of publication approval. ROADMASTER, INC. reserves the right to make changes at any time without notice in material, specification and models or to discontinue models.



# BASEPLATE KIT INSTALLATION INSTRUCTIONS

**KIT# 523206-4**

05/07/21  
KS

ROADMASTER, Inc. 6110 NE 127th Ave. Vancouver, WA 98682 360-896-0407 fax 360-735-9300 www.roadmasterinc.com

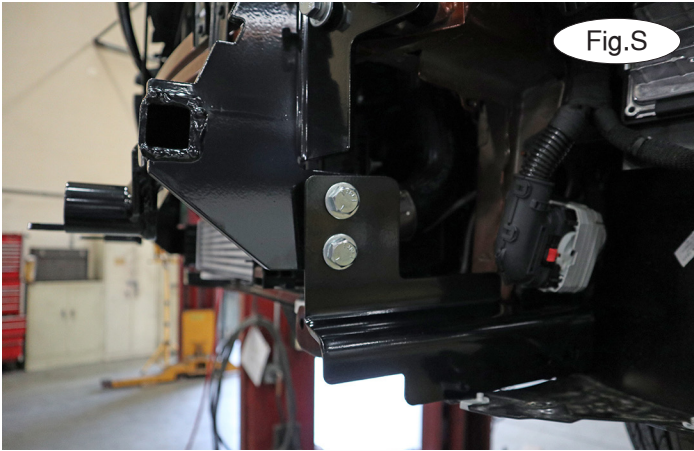

13. Working on the driver's side only, use the drawing on page 1 to locate the driver's side-specific brace. Place ½" small flat washers over two ½" x 1½" bolts, pass the bolts through the side-specific brace and the main receiver, and finish each bolt with a ½" lock washer and ½" nut (Fig.S). Thread them on until they are flush with the ends of the bolts (Fig.T).

14. Use two of the supplied M8 x 1.25 x 30mm bolts, M8 lock washers and 3/8" flat washers and loosely bolt through the two rear mounts of the side-specific brace and into the existing weld nuts in the subframe (Fig.U).

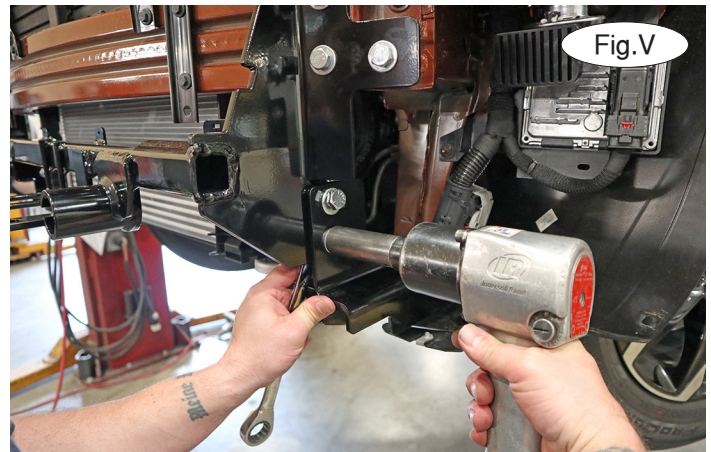
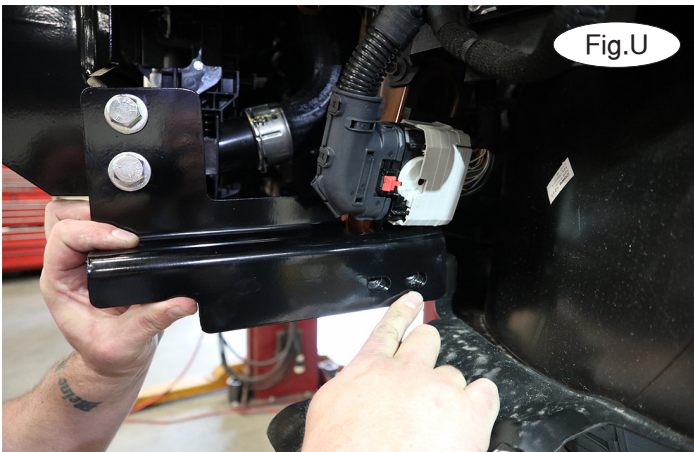

15. Repeat steps 13 and 14 for the passenger side.

16. On each side, push up on the baseplate and then use a 17mm socket to tighten the M10 bolts you previously installed in step 12. Then, apply upward force on the side-specific brace and use a ¾" socket and wrench to tighten the forwardmost bolts (Fig.V). Use a 13mm socket to tighten the two lower bolts. Tighten all bolts to the bolt torque requirements found at the end of these instructions. *Note: use Loctite® Red on all nuts and bolts.*



# BASEPLATE KIT INSTALLATION INSTRUCTIONS

**KIT# 523206-4**

05/07/21  
KS

ROADMASTER, Inc. 6110 NE 127th Ave. Vancouver, WA 98682 360-896-0407 fax 360-735-9300 www.roadmasterinc.com

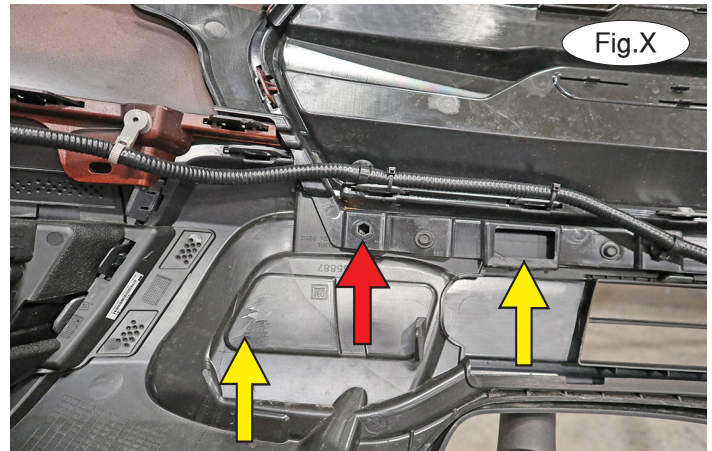
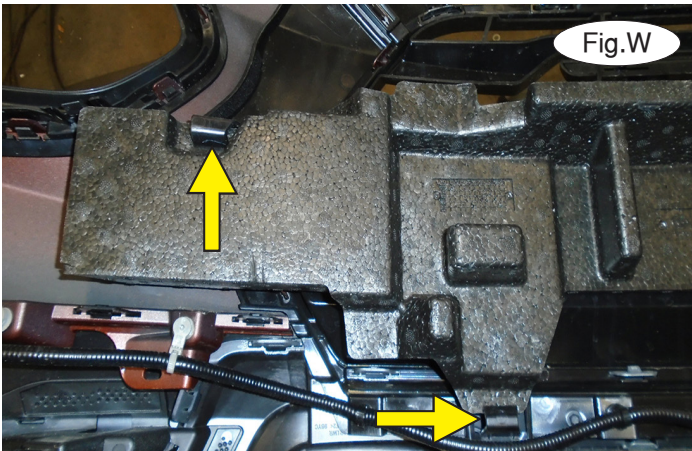

17. On the back of the fascia, remove the foam shock absorption pad by releasing the two clips on each side (Fig.W). It will not be replaced.

18. You will need to relocate the fascia wiring harness to allow clearance for the main receiver brace. To do this, on each side, remove one wiring clip attaching the harness to the back of the fascia (Fig.X and Y – red arrow). Then, use the included zip ties to reattach it to the fascia mounting clips as shown. Now, trim off the outer alignment tab on each side and the lower absorption pad clip (Fig.X and Y – yellow arrows). These figures show the final placement of the wiring harness and the completed trimming.

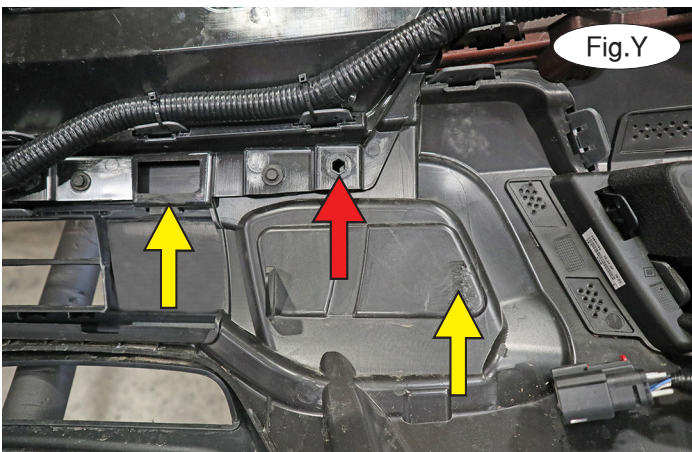

19. **For Activ trim levels only:** Trim the fascia as shown in Figure Z (passenger side). **For all other trim levels:** Cut out the included template on the last page and use it to cut a 2-1/8" hole in the fascia on each side (Fig.AA – driver's side). *Note:* Due to manufacturing variances, additional trimming may be necessary to allow clearance for the main receiver brace.

20. Reinstall the fascia and bumper stiffener, reversing steps 1 through 8.





# BASEPLATE KIT INSTALLATION INSTRUCTIONS

**KIT# 523206-4**

05/07/21  
KS

ROADMASTER, Inc. 6110 NE 127th Ave. Vancouver, WA 98682 360-896-0407 fax 360-735-9300 www.roadmasterinc.com

21. On each side, insert the removable front arm into the front receiver 90 degrees from its final towing position, depressing the spring-loaded pin against the receiver. Twist back 90 degrees until the spring-loaded pin snaps into place in the notch on the receiver, locking the arm into place in its final towing position.

**Please note: it is the owner's responsibility to ensure the locking of the pins before towing. Otherwise, failure of the towing system will result.**

22. Install the tow bar to the mounting bracket according to the manufacturer's instructions.



### IMPORTANT!

**Safety cables are required by law. When towing, connect safety cables to the safety cable tabs illustrated on the first page and in Figure BB. Make certain there is adequate slack in the cables to allow a full turning radius; otherwise, damage will result. If necessary, longer cables or cable extensions are available.**

### Three options for attaching the wiring plug to the main receiver brace

**For six-wire plugs:** use the two supplied 3/4" self-tapping screws to attach the electrical plug directly to the rods on the front of the main receiver brace.

**For four-wire round plugs:** attach to the plug mounting plate and then use the two supplied 3/4" self-tapping screws to attach the mounting plate to the rods on the front of the main receiver brace.

**For four-wire flat plugs:** place the plug through the mounting plug plate, and then secure it using the supplied zip tie on the front of the plug (Fig.CC). Use the two supplied 3/4" self-tapping screws to attach the mounting plate to the rods on the front of the main receiver brace.

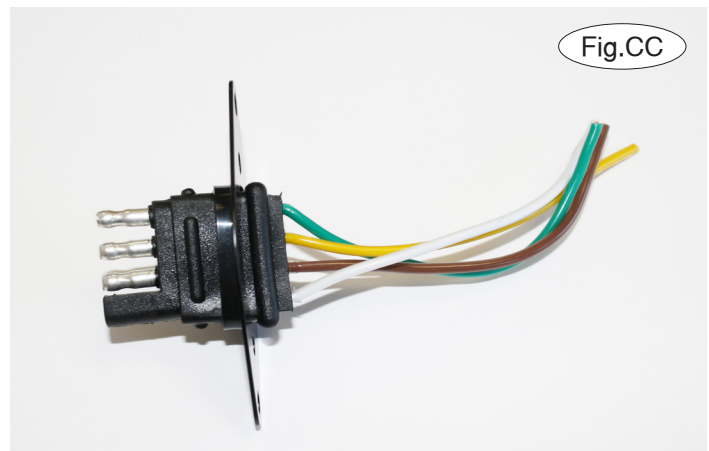

### BOLT TORQUE REQUIREMENTS

Note: The torque values represented below are intended as general guidelines. Torque requirements for specific applications may vary. Roadmaster does not warrant this information to be accurate for all applications and disclaims all liability for any claims or damages which may result from its use.

#### STANDARD BOLTS

Thread Size	Grade	Torque
5/16-18	5	13 ft./lb.
3/8-16	5	23 ft./lb.
7/16-14	5	37 ft./lb.
1/2-13	5	57 ft./lb.
5/8-11	5	112 ft./lb.

#### METRIC BOLTS

Thread Size	Grade	Torque
6mm-1.0	8.8	6 ft./lb.
8mm-1.0	8.8	18 ft./lb.
8mm-1.25	8.8	16 ft./lb.
10mm-1.25	8.8	36 ft./lb.
10mm-1.5	8.8	31 ft./lb.

#### METRIC BOLTS

Thread Size	Grade	Torque
12mm-1.25	8.8	64 ft./lb.
12mm-1.5	8.8	60 ft./lb.
12mm-1.75	8.8	55 ft./lb.
14mm-2.0	8.8	88 ft./lb.

All illustrations and specifications contained herein are based on the latest information available at the time of publication approval. ROADMASTER, INC. reserves the right to make changes at any time without notice in material, specification and models or to discontinue models.

*Trimming Template for non-Activ models only*

