



BASEPLATE KIT INSTALLATION INSTRUCTIONS

KIT# 523218-4

11/1/23
KS

ROADMASTER, Inc. 6110 NE 127th Ave. Vancouver, WA 98682 360-896-0407 fax 360-735-9300 www.roadmasterinc.com

Ratchets
7mm and 10mm sockets
9/16" and 3/4" wrenches and sockets
17/32" bit and drill
T15 Torx driver

What You'll Need

Needlenose pliers
Flathead screwdriver

Reciprocating saw
Permanent marker
Torque wrench
Loctite® Red or Blue
Panel tool

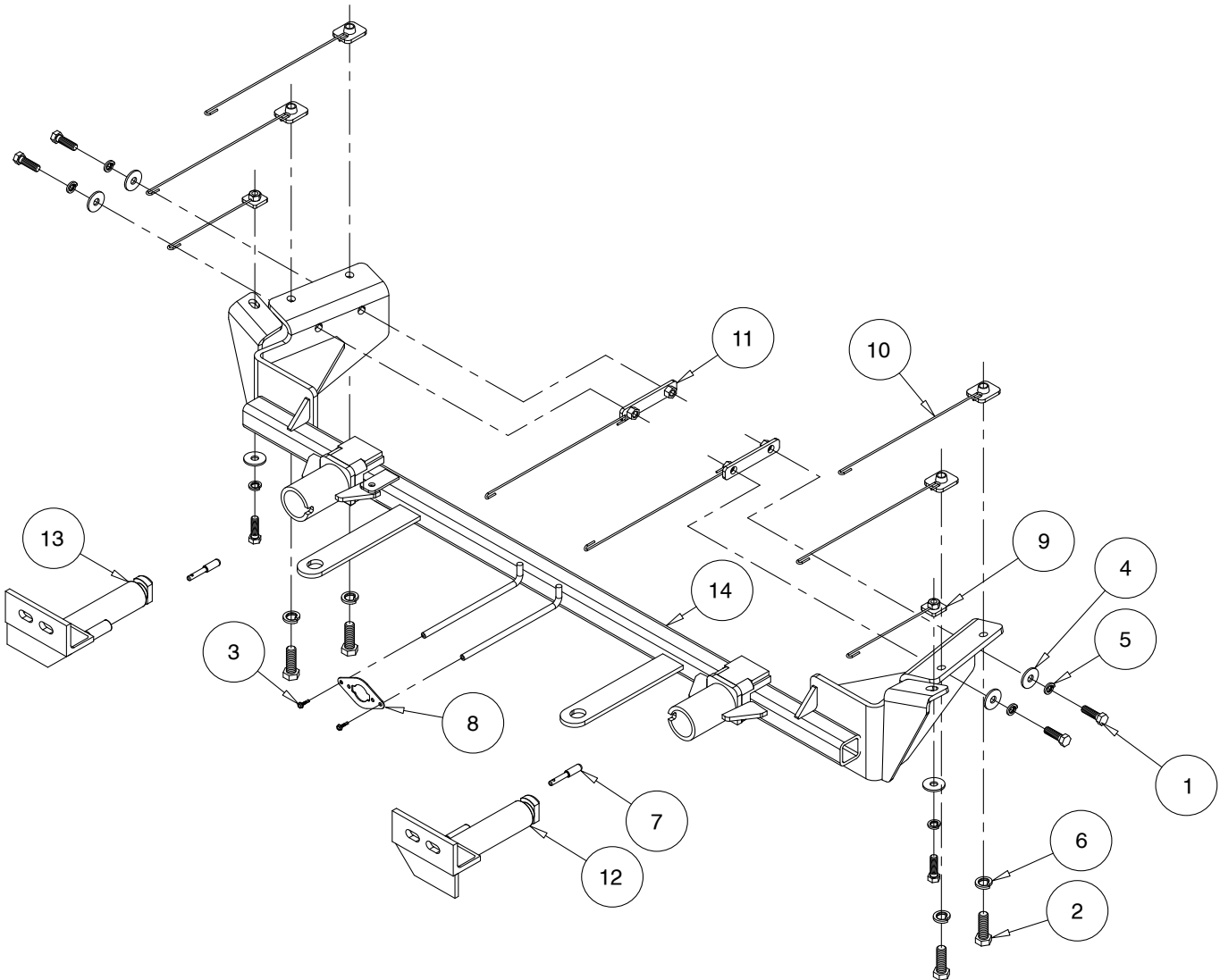

ITEM	QTY	DESCRIPTION	PART#
1.....	6.....	3/8" x 1 1/4" BOLT.....	350056-00
2.....	4.....	1/2 x 1 1/2" BOLT.....	350095-00
3.....	2.....	#10 x 3/4" SELF DRILLING SCREW.....	350247-35
4.....	6.....	3/8" FLAT WASHER.....	350304-00
5.....	6.....	3/8" LOCK WASHER.....	350305-00
6.....	4.....	1/2" LOCK WASHER.....	350309-00
7.....	2.....	LOCK PIN.....	A000008
8.....	1.....	WIRE PLUG PLATE.....	A003801
9.....	2.....	1" x 1" BACKING PLATE W/ 3/8" NUT & 6" ROD.....	C001948
10.....	4.....	1 1/4" x 1 1/2" THREADED BACKING PLATE W/ 10" ROD.....	C002501
11.....	2.....	3/4" x 4" BACKING PLATE W/ 3/8" NUTS & 10" ROD.....	C003438
12.....	1.....	DRIVER SIDE ARM.....	C003698
13.....	1.....	PASSENGER SIDE ARM.....	C003699
14.....	1.....	MAIN RECEIVER.....	C003700



BASEPLATE KIT INSTALLATION INSTRUCTIONS

KIT# 523218-4

11/1/23
KS

ROADMASTER, Inc. 6110 NE 127th Ave. Vancouver, WA 98682 360-896-0407 fax 360-735-9300 www.roadmasterinc.com

This is one of our crossbar-style baseplates, which allows the visible front portion of the bracket to be easily removed from the front of the vehicle (Fig.A and Fig.B).

The baseplate mounts to the frame of the vehicle and consists of a main receiver brace, two rear support braces, two removable front braces, and a hardware pack.

Before starting the installation, lay out the kit components in order, as they will be used. This will give you a visual idea of how the components work, and will also confirm that everything is present and accounted for.



IMPORTANT: All baseplates **must** be assembled with all the bolts left loose for final adjustment and positioning (before tightening) unless otherwise instructed. All bolts **must** be torqued for proper strength. If more than one bolt is used per fastening point, the diagram may only show one. Use flat washers over all slotted holes and lock washers on all fasteners.

WARNING

Failure to heed these warnings or follow the installation instructions may result in a voided warranty, loss of towed vehicle, personal injury or death.

- Do not weld or modify this baseplate or its components. Welding or modification will void the warranty.
- Do not use this document as a basis to design/fabricate a baseplate, as it may not show all parts or structural components.
- We strongly recommend professional installation.
- If the towed vehicle has been in an accident, it must be properly repaired before attaching the baseplate. Do not install the baseplate if any structural frame damage is found.
- The installer must use all bolts and parts supplied. If running changes were made by the vehicle manufacturer after this kit was designed, some bolts or other fasteners may no longer be the correct size. It is the installer's responsibility to verify this kit is securely fastened to the vehicle.
- Use Loctite® Red on all bolts used to secure this baseplate. Torque all bolts to the specifications found at the end of these instructions. Do not over-torque the bolts or failure may occur.
- The installer must inspect the baseplate to ensure adequate clearance, particularly around hoses, air conditioner lines, radiators, etc. or non-warranty failure may result.
- Roadmaster manufactures many styles of baseplates. If your baseplate has removable arms, they must be removed before driving the vehicle, unless the arms can be pinned or padlocked in place. If not secured, the arms could vibrate out.
- Some motorhome chassis have such a tight turning radius that you can damage your motorhome, towed vehicle, tow bar or baseplate while turning sharply. Before getting on the road, test your turning radius in an empty parking lot. Turning too sharply could result in non-warranty damage to your towing system, motorhome and/or towed vehicle.
- Do not back up with the towed vehicle attached or non-warranty damage will occur to your towing system or vehicles.
- The safety cables must connect the towing vehicle to the towed vehicle frame to frame, with the cables crossed, with enough slack for sharp turns. See cable instructions for proper routing. Failure to do so will result in non-warranty damage and/or the loss of the towed vehicle.
- This kit is designed for use with ROADMASTER tow bars and ROADMASTER adapters only. Using this kit with other brands, without an approved ROADMASTER adapter, may result in non-warranty damage or injury.
- Receiver extensions and out-of-level towing situations of 3 inches or more. This can cause the system to swing much higher and lower, causing excessive strain on the tow bar, baseplate and frame. That can cause the towing system to fail, causing property damage, personal injury or even death. If you must use a receiver extension or drop hitch to tow, it will reduce your receiver's weight capacity by 1/3 to avoid damaging your system. Never use more than one extension and/or drop hitch, as this will void your warranty.
- Every 3,000 miles, the owner must inspect all mounting points for cracks or fatigue, and check the fasteners for proper torque, according to the bolt torque requirements chart on the last page of these instructions.
- The owner must follow the vehicle manufacturer's instructions to prepare the vehicle for towing. Failure to do so may cause severe damage to the vehicle.
- This baseplate is only warranted for the original installation. Installing a used baseplate on another vehicle is not recommended and will void the warranty.



BASEPLATE KIT INSTALLATION INSTRUCTIONS

KIT# 523218-4

11/1/23
KS

ROADMASTER, Inc. 6110 NE 127th Ave. Vancouver, WA 98682 360-896-0407 fax 360-735-9300 www.roadmasterinc.com

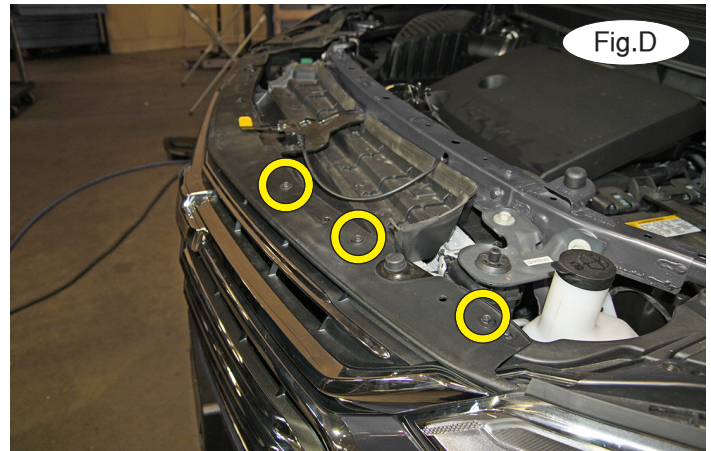
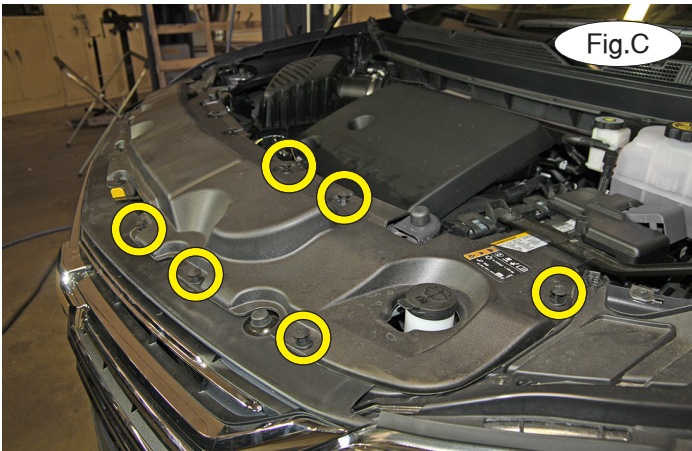

Important: please use all supplied bolts and parts and read all instructions carefully before beginning this installation. The majority of questions you may have can be answered within the text, and proper installation will ensure safe and secure travel.

1. On each side, remove six plastic fasteners attaching the radiator cover to the fascia and core support (Fig.C). Set it aside for now.
2. On each side, remove three 7mm (head) screws attaching the fascia to the core support (Fig.D).

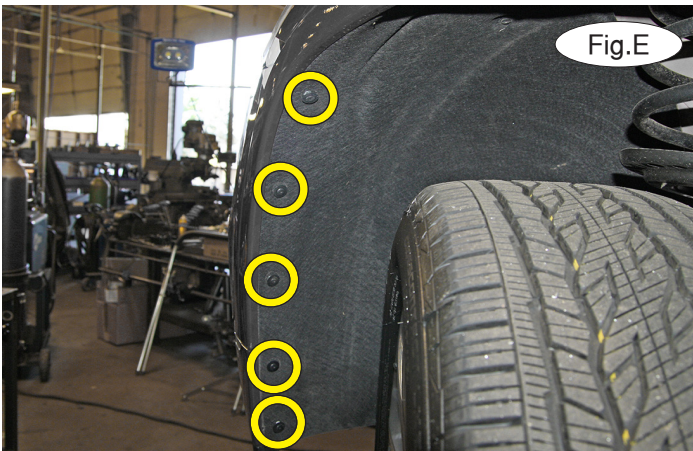

3. On each side, remove five T15 (head) screws attaching the fender liner to the fascia (Fig.E).
4. On each side, pull out on the bottom of the fender well trim to release the first five clips attaching it to the fender and fascia. *Note: It may be helpful to release the top two clips from inside the fender (Fig.F).*
5. On each side, remove one 7mm (head) screw attaching the fender to the frame (Fig.G – arrow) and three 10mm head bolts attaching the back of the fog light to the frame (Fig.G – circles).

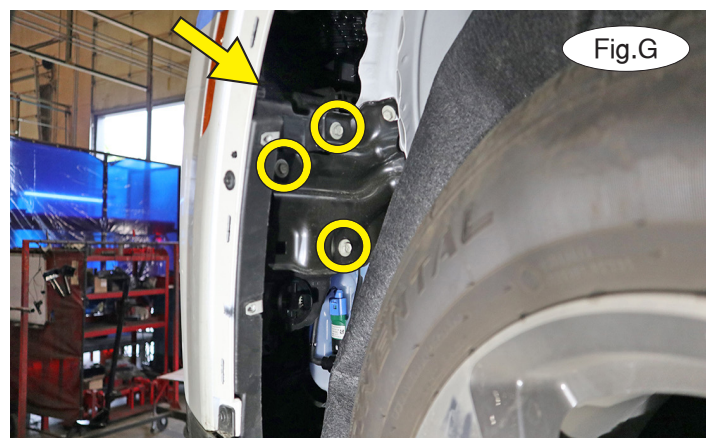



BASEPLATE KIT INSTALLATION INSTRUCTIONS

KIT# 523218-4

11/1/23
KS

ROADMASTER, Inc. 6110 NE 127th Ave. Vancouver, WA 98682 360-896-0407 fax 360-735-9300 www.roadmasterinc.com

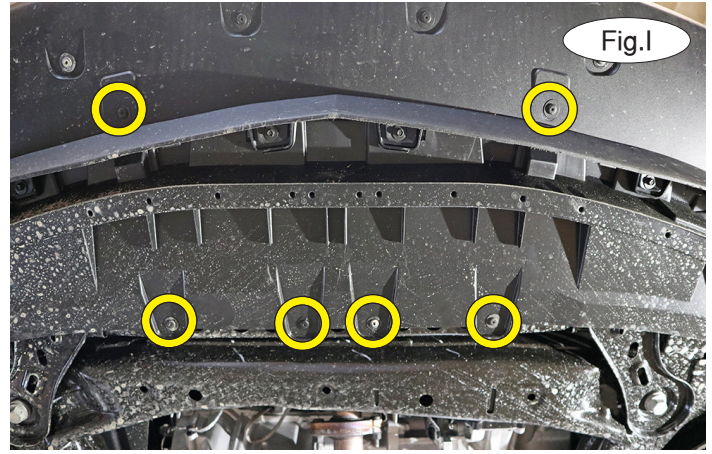

6. On each side, remove three T15 Torx (head) screws attaching the bottom of the fender well to the fascia (Fig.H).
7. Remove six T15 Torx (head) screws attaching the bottom of the fascia to the subframe (Fig.I).



8. On each side, disconnect any wiring harnesses attaching the fascia to the vehicle. Then, lift up on the top of the grille and pull out on the corner to release the fascia (Fig.J). Set the fascia aside for now.

9. Use a panel tool or flathead screwdriver to release the plug (Fig.K). Remove three 7mm screws attaching the ACC bracket to the bumper core (Fig.L). Set aside the ACC unit and its bracket for now.

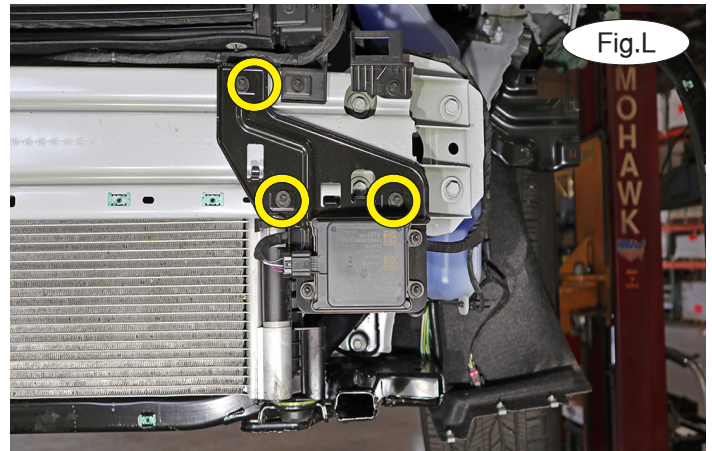



BASEPLATE KIT INSTALLATION INSTRUCTIONS

KIT# 523218-4

11/1/23
KS

ROADMASTER, Inc. 6110 NE 127th Ave. Vancouver, WA 98682 360-896-0407 fax 360-735-9300 www.roadmasterinc.com

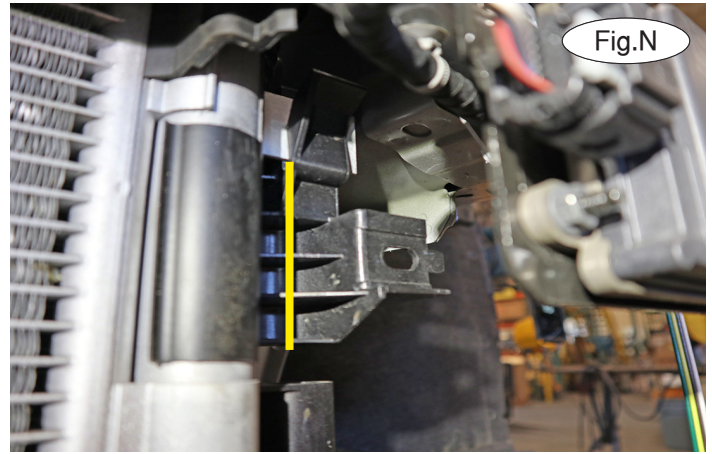
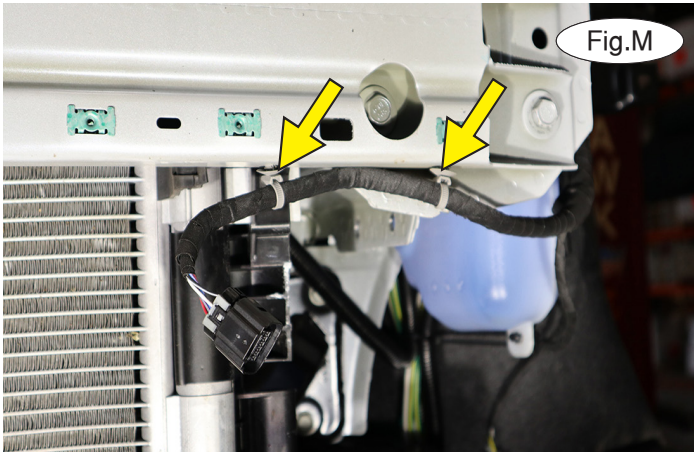

10. Release two wiring harness clips attaching the ACC harness to the bumper core (Fig.M).

11. On the driver's side only, trim off the shutter housing mount using the yellow line as a reference (Fig.N).

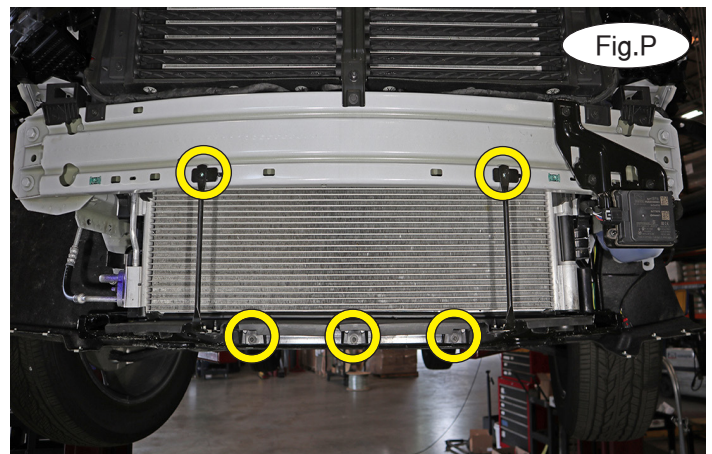
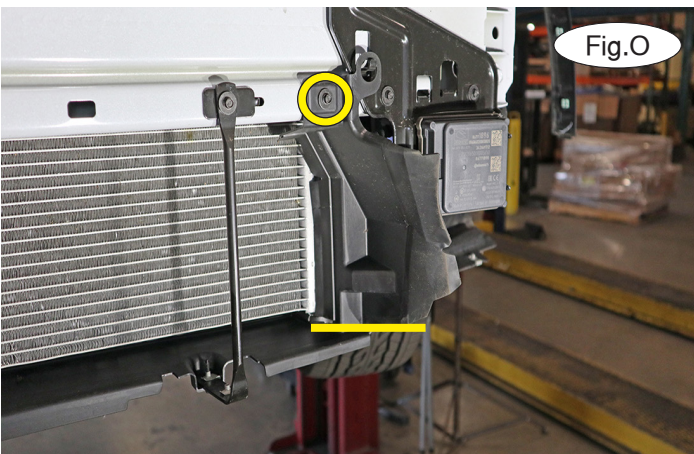

12. On each side, trim off the air dam using the yellow line as a reference (Fig.O – driver's side). Then, remove the 7mm bolt attaching it to the bumper core (Fig.O – circle).

13. Remove five 7mm bolts attaching the air dam and bumper support to the vehicle (Fig.P). It will not be replaced.

14. On each side, trim the bottom of the bumper core flange using the yellow line in Figure Q as a guide for trimming.





BASEPLATE KIT INSTALLATION INSTRUCTIONS

KIT# 523218-4

11/1/23
KS

ROADMASTER, Inc. 6110 NE 127th Ave. Vancouver, WA 98682 360-896-0407 fax 360-735-9300 www.roadmasterinc.com

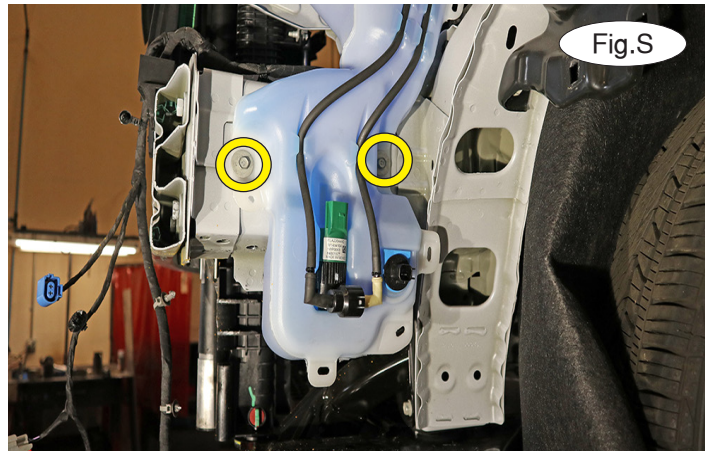

15. On the driver's side only, unclip and disconnect all washer bottle wiring harnesses (Fig.R) and then remove two 10mm (head) bolts attaching the washer bottle to the bumper core (Fig.S). Now, detach and disconnect the fluid lines from the reservoir and temporarily cap the release valves to avoid fluid loss. Remove one 10mm nut attaching the washer bottle to the core support (Fig.T). Then, gently maneuver it out of the framing and set it aside for now.

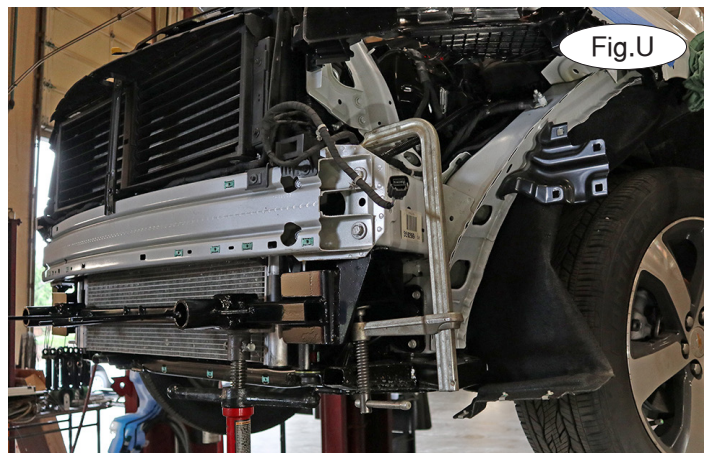
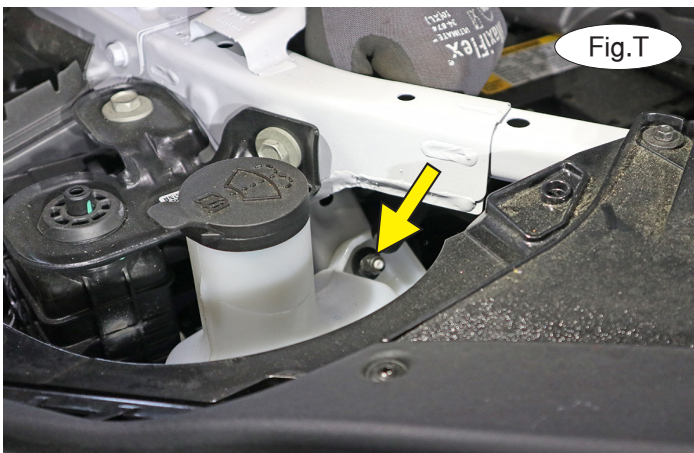

16. Hold the main receiver brace under the bumper core and alongside the pinch weld on each side. Place the brace so that the forwardmost hole aligns with the existing hole in the frame. Use a jackstand and large C clamp to hold it snug against the bumper core (Fig.U). Then, working on the driver's side only, mark the holes and drill them out – the upper holes are 1/2" (Fig.V – arrows) and the lower ones are 3/8" (Fig.V – circles).

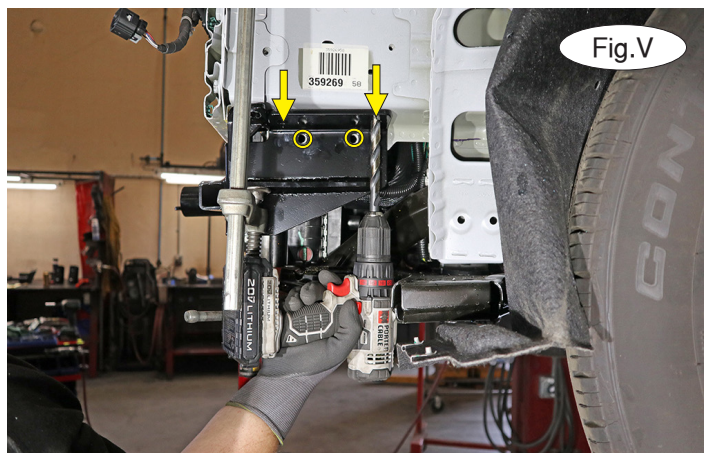



BASEPLATE KIT INSTALLATION INSTRUCTIONS

KIT# 523218-4

11/1/23
KS

ROADMASTER, Inc. 6110 NE 127th Ave. Vancouver, WA 98682 360-896-0407 fax 360-735-9300 www.roadmasterinc.com

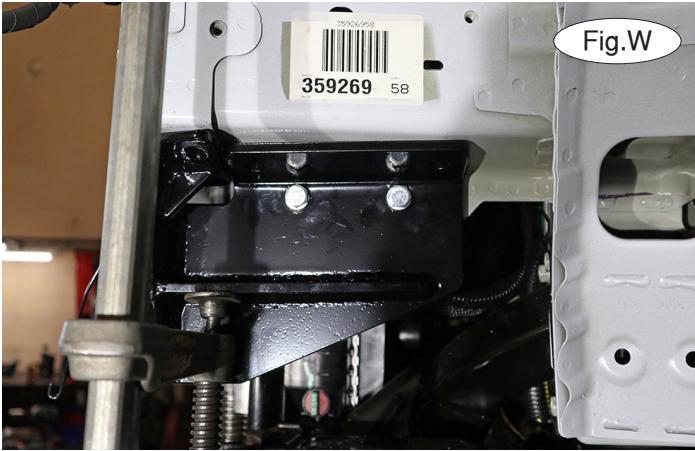

17. Place two 3/8" lock washers over two 3/8" x 1/4" bolts. Then, place a double-nutted backing plate with 10" inch rod on the inside of the frame and bolt through the lower holes of the brace and into the threaded backing plate (Fig.W).

18. Place two 3/16" x 1 1/4" x 1 1/2" threaded backing plates with 10" rod through the access hole in the end of the bumper core (Fig.X) and over the upper holes you drilled in step 16. Now, place two 1/2" lock washers over two 1/2" x 1 1/2" bolts and bolt up into the threaded backing plates (Fig.Y – arrows).

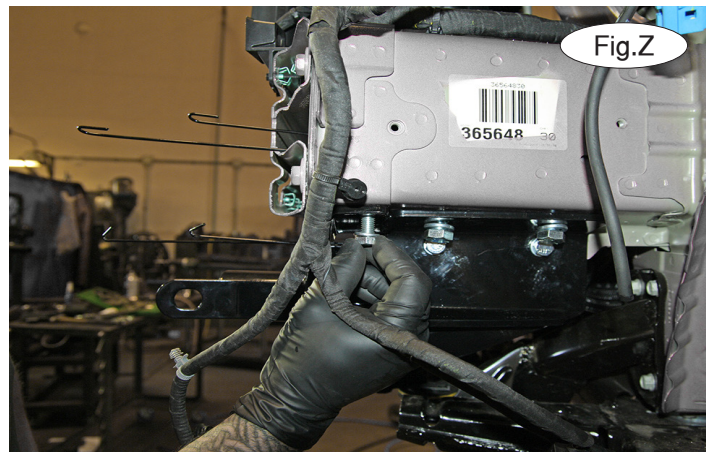
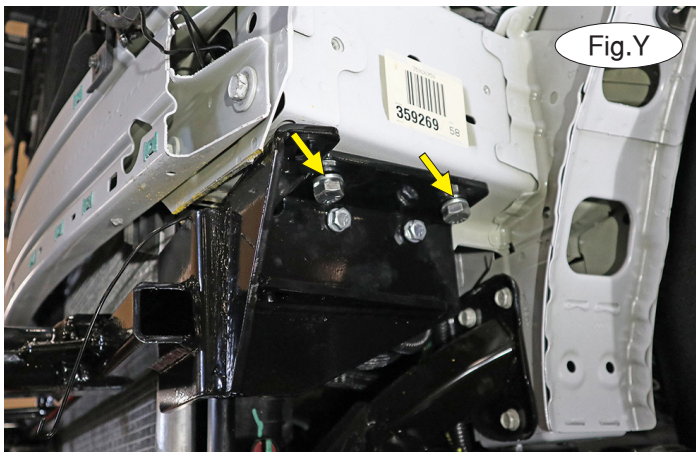

19. Place a 3/8" nutted backing plate with 6" rod inside the bumper core over the forwardmost mount. Place a 3/8" lock washer over a 3/8" x 1/4" bolt and bolt up into the threaded backing plate (Fig.Z).

20. Repeat steps 14 through 18 for the passenger side of the vehicle.

21. Torque the upper 1/2" bolts to the bolt torque requirements found at the end of these instructions. Then, tighten the lower 3/8" bolts and then the remaining 3/8" bolts. **Note: Use Loctite® Red on all nuts and bolts. IMPORTANT! Do not use an impact gun, or you will break off the factory weld nuts.** Trim the rods off, or bend them out of the way.

22. Reinstall the washer bottle by reversing step 14.



BASEPLATE KIT INSTALLATION INSTRUCTIONS

KIT# 523218-4

11/1/23
KS

ROADMASTER, Inc. 6110 NE 127th Ave. Vancouver, WA 98682 360-896-0407 fax 360-735-9300 www.roadmasterinc.com



Fig.AA

23. On each side, trim just enough to allow clearance for the receiver, safety cable tab and locking pin on the arm (Fig. AA). Then, reinstall the fascia, reversing steps 1 through 8.

24. On each side, insert the removable front arm into the front receiver 90 degrees from its final towing position, depressing the spring-loaded pin against the receiver. Twist back 90 degrees until the spring-loaded pin snaps into place in the notch on the receiver, locking the arm into place in its final towing position. **Please note: It is the owner's responsibility to ensure the locking of the pins before towing. Otherwise, failure of the towing system will result.**

25. Install the tow bar to the baseplate according to the manufacturer's instructions.

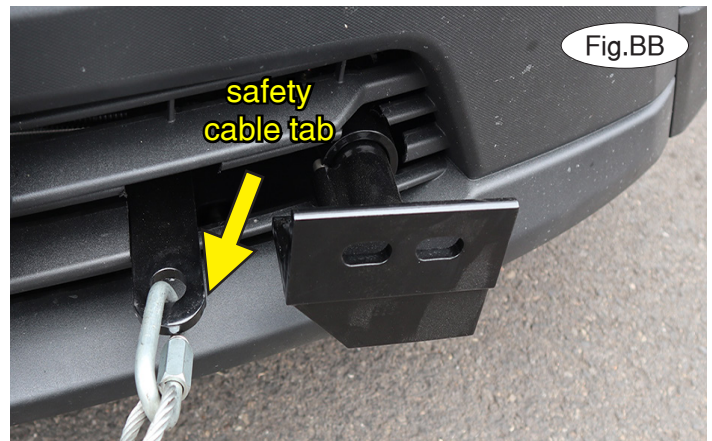

Fig.BB

IMPORTANT!

Safety cables are required by law. When towing, connect safety cables to the safety cable tabs illustrated in Figure BB. Make certain there is adequate slack in the cables to allow a full turning radius; otherwise, damage will result. If necessary, longer cables or cable extensions are available.



BASEPLATE KIT INSTALLATION INSTRUCTIONS

KIT# 523218-4

11/1/23
KS

ROADMASTER, Inc. 6110 NE 127th Ave. Vancouver, WA 98682 360-896-0407 fax 360-735-9300 www.roadmasterinc.com

Three options for attaching the wiring plug to the main receiver brace

For six-wire plugs: use the two supplied 3/4" self-tapping screws to attach the electrical plug directly to the rods on the front of the main receiver brace.

For four-wire round plugs: attach to the plug mounting plate and then use the two supplied 3/4" self-tapping screws to attach the mounting plate to the rods on the front of the main receiver brace.

For four-wire flat plugs: place the plug through the mounting plug plate, and then secure it using the supplied zip tie on the front of the plug (Fig.CC). Use the two supplied 3/4" self-tapping screws to attach the mounting plate to the rods on the front of the main receiver brace.

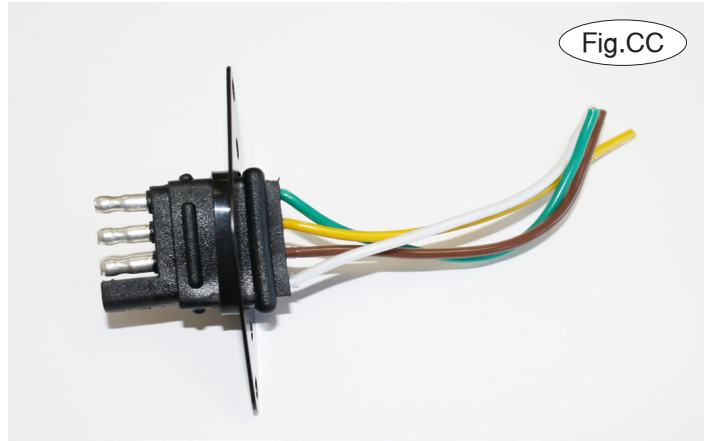

Fig.CC

BOLT TORQUE REQUIREMENTS

Note: The torque values represented below are intended as general guidelines. Torque requirements for specific applications may vary. Roadmaster does not warrant this information to be accurate for all applications and disclaims all liability for any claims or damages which may result from its use.

STANDARD BOLTS

Thread Size	Grade	Torque
5/16-18	5	13 ft./lb.
3/8-16	5	23 ft./lb.
7/16-14	5	37 ft./lb.
1/2-13	5	57 ft./lb.
5/8-11	5	112 ft./lb.

METRIC BOLTS

Thread Size	Grade	Torque
6mm-1.0	8.8	6 ft./lb.
8mm-1.0	8.8	18 ft./lb.
8mm-1.25	8.8	16 ft./lb.
10mm-1.25	8.8	36 ft./lb.
10mm-1.5	8.8	31 ft./lb.

METRIC BOLTS

Thread Size	Grade	Torque
12mm-1.25	8.8	64 ft./lb.
12mm-1.5	8.8	60 ft./lb.
12mm-1.75	8.8	55 ft./lb.
14mm-2.0	8.8	88 ft./lb.

All illustrations and specifications contained herein are based on the latest information available at the time of publication approval. ROADMASTER, INC. reserves the right to make changes at any time without notice in material, specification and models or to discontinue models.