



BASEPLATE KIT INSTALLATION INSTRUCTIONS

KIT# 523222-4

04/16/2024
RS

ROADMASTER, Inc. 6110 NE 127th Ave. Vancouver, WA 98682 360-896-0407 fax 360-735-9300 www.roadmasterinc.com

Second person to assist
Ratchet and extensions
7, 13, 15, and 18mm sockets

What You'll Need
3/4" and 18mm wrench
T15 Torx driver

Panel tool
Torque wrench
Loctite® Red or Blue

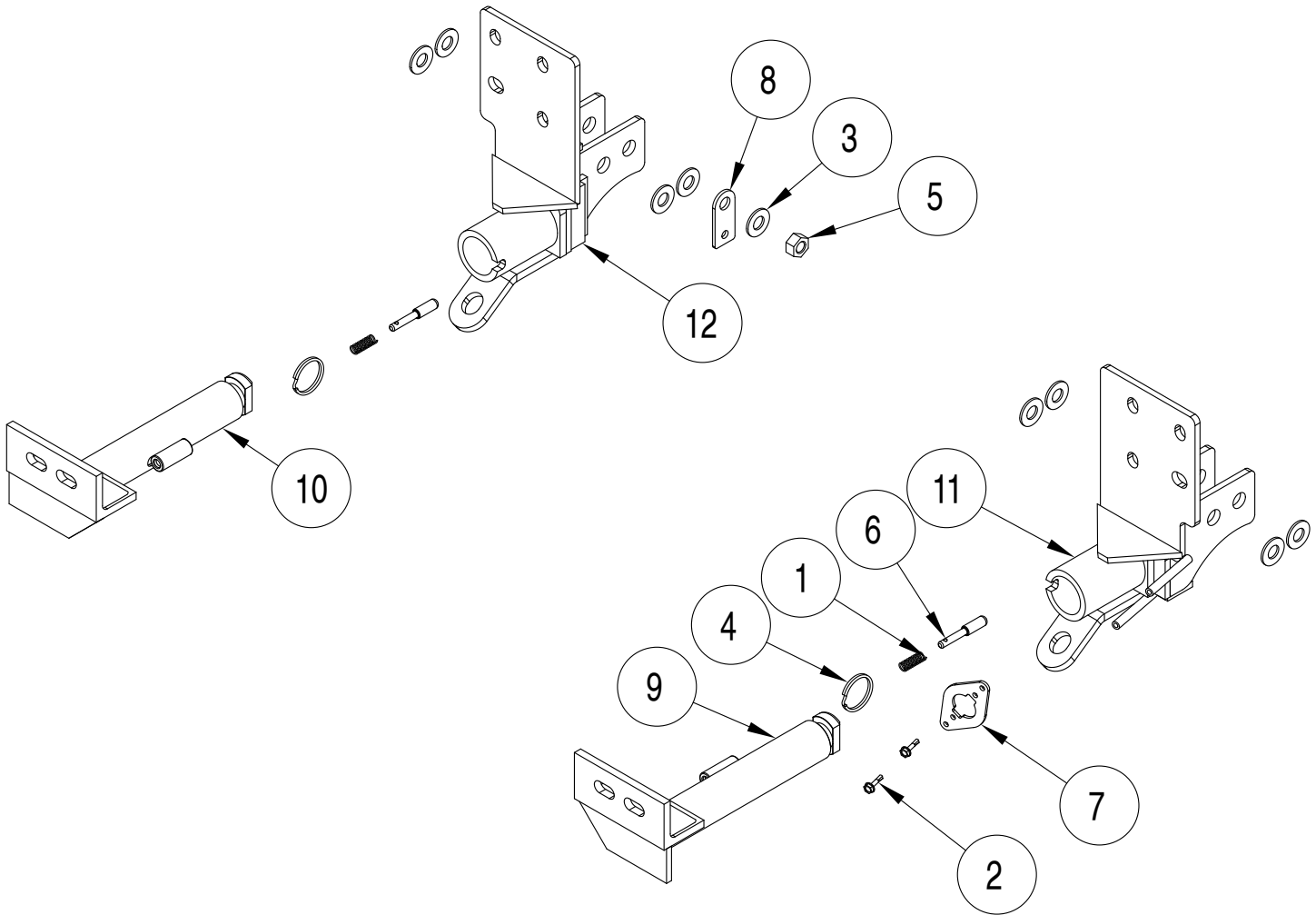

ITEM	QTY	DESCRIPTION	PART NUMBER
1	2	SPRING	200146-00
2	2	#10 x 3/4" SELF DRILLING SCREW	350247-35
3	9	1/2" SAE WASHER	350308-20
4	2	RING	350520-00
5	1	M12 x 1.75 HEX NUT	357212-00
6	2	LOCK PIN	A000008
7	1	WIRE PLUG PLATE	A003801
8	1	BRAKEAWAY TAB	A006652
9	1	DRIVER SIDE ARM	C003766
10	1	PASSENGER SIDE ARM	C003767
11	1	DRIVER SIDE RECEIVER	C003768
12	1	PASSENGER SIDE RECEIVER	C003769



BASEPLATE KIT INSTALLATION INSTRUCTIONS

KIT# 523222-4

04/16/2024
RS

ROADMASTER, Inc. 6110 NE 127th Ave. Vancouver, WA 98682 360-896-0407 fax 360-735-9300 www.roadmasterinc.com

This is one of our crossbar-style baseplates, which allows the visible front portion of the bracket to be easily removed from the front of the vehicle (Fig.A and Fig.B). The baseplate consists of two main receiver braces, two removable front braces and a hardware pack.

The main receiver braces mount to the frame rails, bumper core and tow hook mounts. The removable front braces install in the main receiver braces.

Before starting the installation, lay out the kit components in order, as they will be used. This will give you a visual idea of how the components work, and will also confirm that everything is present and accounted for.



IMPORTANT: All baseplates **must** be assembled with all the bolts left loose for final adjustment and positioning (before tightening) unless otherwise instructed. All bolts **must** be torqued for proper strength. If more than one bolt is used per fastening point, the diagram may only show one. Use flat washers over all slotted holes and lock washers on all fasteners.

WARNING

Failure to heed these warnings or follow the installation instructions may result in a voided warranty, loss of towed vehicle, personal injury or death.

- Do not weld or modify this baseplate or its components. Welding or modification will void the warranty.
- Do not use this document as a basis to design/fabricate a baseplate, as it may not show all parts or structural components.
- We strongly recommend professional installation.
- If the towed vehicle has been in an accident, it must be properly repaired before attaching the baseplate. Do not install the baseplate if any structural frame damage is found.
- The installer must use all bolts and parts supplied. If running changes were made by the vehicle manufacturer after this kit was designed, some bolts or other fasteners may no longer be the correct size. It is the installer's responsibility to verify this kit is securely fastened to the vehicle.
- Use Loctite® Red on all bolts used to secure this baseplate. Torque all bolts to the specifications found at the end of these instructions. Do not over-torque the bolts or failure may occur.
- The installer must inspect the baseplate to ensure adequate clearance, particularly around hoses, air conditioner lines, radiators, etc. or non-warranty failure may result.
- Roadmaster manufactures many styles of baseplates. If your baseplate has removable arms, they must be removed before driving the vehicle, unless the arms can be pinned or padlocked in place. If not secured, the arms could vibrate out.
- Some motorhome chassis have such a tight turning radius that you can damage your motorhome, towed vehicle, tow bar or baseplate while turning sharply. Before getting on the road, test your turning radius in an empty parking lot. Turning too sharply could result in non-warranty damage to your towing system, motorhome and/or towed vehicle.
- Do not back up with the towed vehicle attached or non-warranty damage will occur to your towing system or vehicles.
- The safety cables must connect the towing vehicle to the towed vehicle frame to frame, with the cables crossed, with enough slack for sharp turns. See cable instructions for proper routing. Failure to do so will result in non-warranty damage and/or the loss of the towed vehicle.
- This kit is designed for use with ROADMASTER tow bars and ROADMASTER adapters only. Using this kit with other brands, without an approved ROADMASTER adapter, may result in non-warranty damage or injury.
- Receiver extensions and out-of-level towing situations of 3 inches or more. This can cause the system to swing much higher and lower, causing excessive strain on the tow bar, baseplate and frame. That can cause the towing system to fail, causing property damage, personal injury or even death. If you must use a receiver extension or drop hitch to tow, it will reduce your receiver's weight capacity by 1/3 to avoid damaging your system. Never use more than one extension and/or drop hitch, as this will void your warranty.
- Every 3,000 miles, the owner must inspect all mounting points for cracks or fatigue, and check the fasteners for proper torque, according to the bolt torque requirements chart on the last page of these instructions.
- The owner must follow the vehicle manufacturer's instructions to prepare the vehicle for towing. Failure to do so may cause severe damage to the vehicle.
- This baseplate is only warranted for the original installation. Installing a used baseplate on another vehicle is not recommended and will void the warranty.



BASEPLATE KIT INSTALLATION INSTRUCTIONS

KIT# 523222-4

04/16/2024
RS

ROADMASTER, Inc. 6110 NE 127th Ave. Vancouver, WA 98682 360-896-0407 fax 360-735-9300 www.roadmasterinc.com

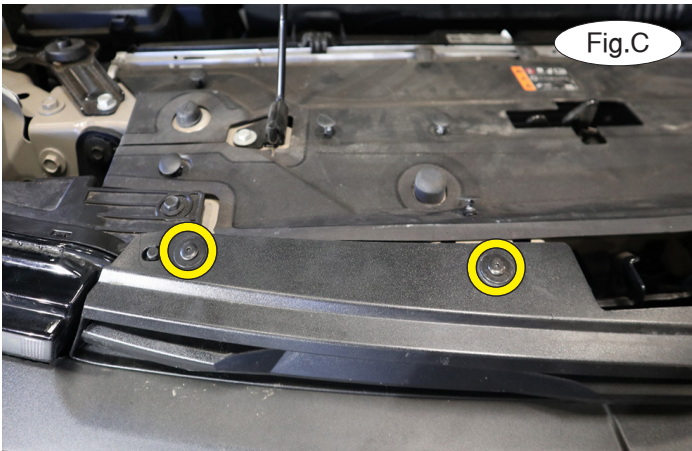

Important: Please use all supplied bolts and parts and read all instructions carefully before beginning this installation. The majority of questions you may have can be answered within the text, and proper installation will ensure safe and secure travel.

1. On each side, remove two T15 Torx screws attaching the top of the grill to the core support (Fig C).
2. On each side, pull firmly on the fender flare until you release two orange clips. Now, prop it with a soft rag (Fig D).
Note: Due to manufacturing variances in trim level, your vehicle may not have fender flares. If it doesn't, proceed to the next step.

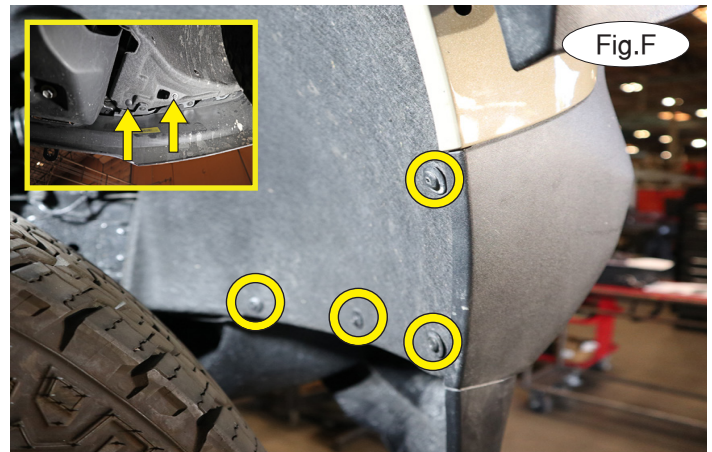
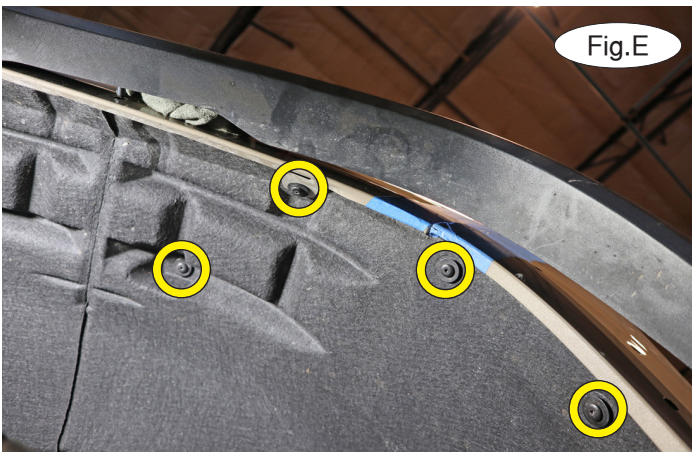

3. On each side, remove eight T15 Torx screws attaching the fender to the fascia (Fig E and F). On the ZR2 Models there may be seven T15 Torx screws. *Note: Due to manufacturing variances in trim level, there may also be an additional T15 screw and a plastic fastener to remove (Fig.F – inset).*

4. On each side, pull the fender liner back and remove two T15 Torx screws attaching the subframe to the fascia (Fig.G).

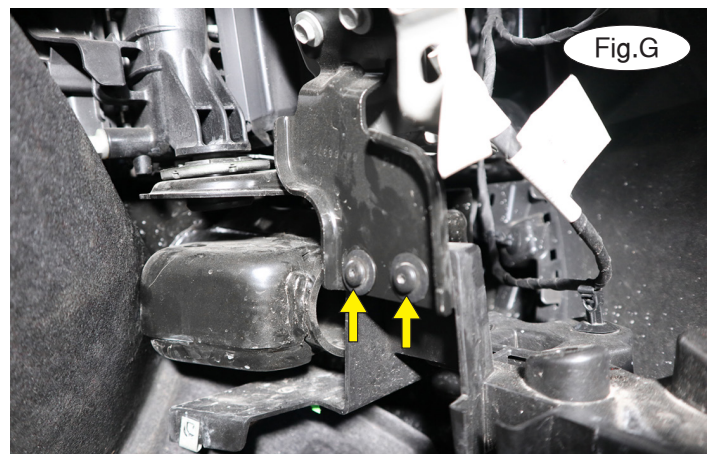



BASEPLATE KIT INSTALLATION INSTRUCTIONS

KIT# 523222-4

04/16/2024
RS

ROADMASTER, Inc. 6110 NE 127th Ave. Vancouver, WA 98682 360-896-0407 fax 360-735-9300 www.roadmasterinc.com

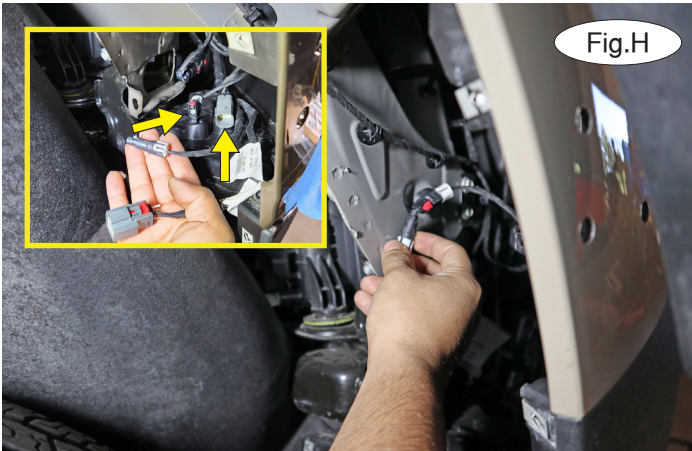

Fig.H



Fig.I

5. On the passenger side only, disconnect the front camera (Fig H). If the vehicle is equipped with fog lights, disconnect them as well. *Note: For the ZR2 model; unplug both camera and fog lights, two will also need to be unplugged from a mount before removing the fascia. (Fig. H inset).*

6. **If you are installing on the ZR2 model:** steps 6, 7, and 8 are different. See Page 8 for supplemental instructions. On each side, remove two T15 Torx screws attaching the bottom of the fascia to the bottom of the bumper core (Fig. I).



Fig.J



Fig.K

7. On each side, pull firmly up and out at the seam to release the fascia (Fig.J). Then, pull up to release the top of the fascia from the retaining pin (Fig.K). Set the fascia aside for now.

8. Remove five plastic fasteners attaching the splash shield to the bottom of the core support (Fig L – arrows). Then, remove five 13mm bolts attaching the splash shield to the lower control arm bracket (Fig.L – circles).

9. On each side, use an 18mm wrench to remove two 12mm bolts and nuts attaching the tow hook to the frame (Fig.M). The tow hooks will not be replaced but retain the hardware for replacement in a future step.

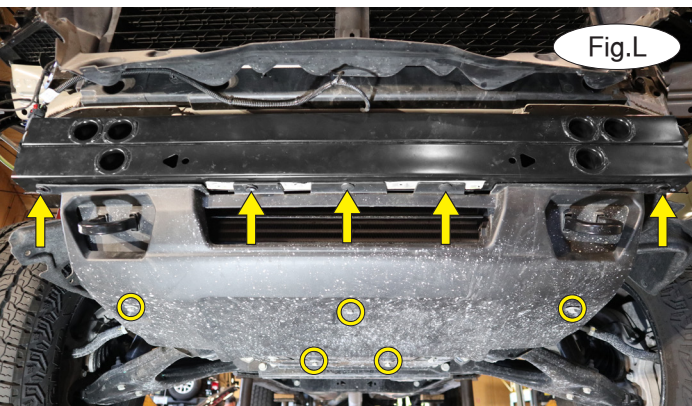

Fig.L



Fig.M



BASEPLATE KIT INSTALLATION INSTRUCTIONS

KIT# 523222-4

04/16/2024
RS

ROADMASTER, Inc. 6110 NE 127th Ave. Vancouver, WA 98682 360-896-0407 fax 360-735-9300 www.roadmasterinc.com

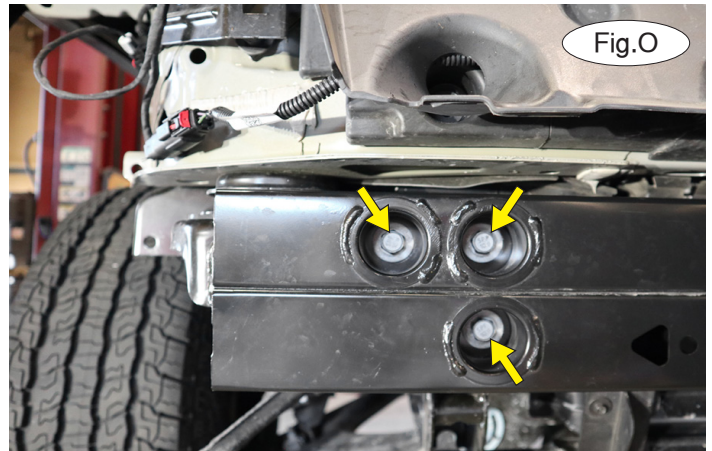
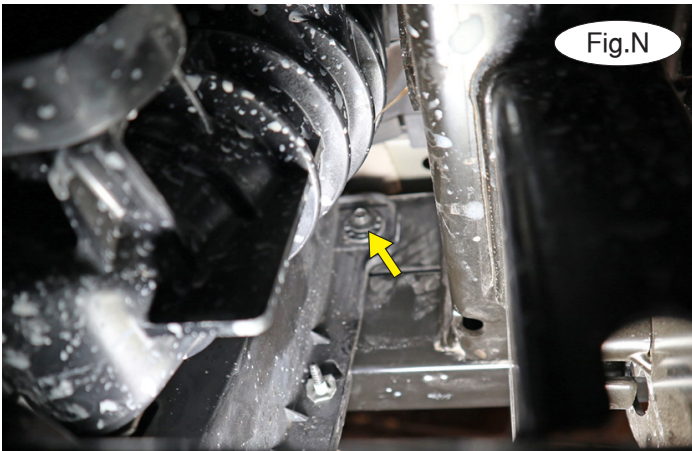

10. On each side, remove one 7mm screw from behind the bumper core attaching the lower shutter assembly to the back of the bumper core (Fig N).

11. On each side, remove three 15mm bolts attaching the bumper core to the frame (Fig O). Set it aside for now (Fig.P). Retain the hardware for replacement in a future step.

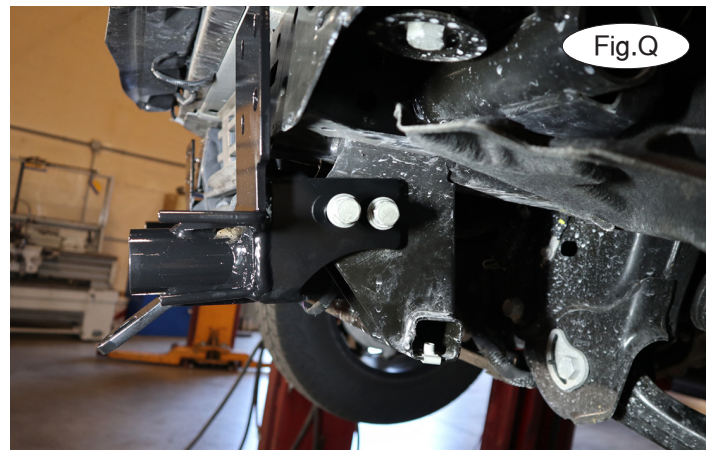

12. On each side, use the drawing on page one to locate the side-specific rear brace. Place ½" SAE washers on the tow hook bolts that you removed in step 9. Bolt through the brace and tow hook mount. Finish each bolt with an ½" SAE washer, Loctite and one of the factory nuts (Fig.Q). Do not fully tighten these until step 14.

13. Replace the bumper core and the factory 15mm bolts (Fig.R). *Note: For the ZR2 model: reattach the skid plate and rock guard, reversing steps S1, S2, S3, and S4.*

14. Replace the 7mm screws, reversing step 10.





BASEPLATE KIT INSTALLATION INSTRUCTIONS

KIT# 523222-4

04/16/2024
RS

ROADMASTER, Inc. 6110 NE 127th Ave. Vancouver, WA 98682 360-896-0407 fax 360-735-9300 www.roadmasterinc.com



15. **If you are not using our Breakaway:** Proceed to step 16. **If you are using our Breakaway:** Install it now on the passenger side rear tow hook bolt. Place a 1/2" SAE washer over the bolt threads and bolt through the provided two hole backing plate, and finish with a 12mm x 1.75 nut (Fig.S). Tighten the nut using a 3/4" wrench.

16. Place Loctite on all bolts and then tighten to the bolt torque requirements found at the end of these instructions.



17. **If you are NOT using our Breakaway:** Trim the driver's side and passenger side fascia as shown in Figure T. **If you are using our Breakaway:** Trim the passenger side as shown in Figure U, allowing clearance for the Breakaway switch. The trimming on the driver's side remains the same.

18. **If you are NOT using our Breakaway:** Trim the driver's side and passenger side splash shield as shown in Figure V. **If you are using our Breakaway:** Trim the passenger side as shown in Figure W, allowing clearance for the Breakaway switch. The trimming on the driver's side remains the same.

19. For the ZR2 model additional trimming maybe required to the bottom skid plate.

19. Reinstall the splash shield and the fascia, reversing steps 1 through 8.





BASEPLATE KIT INSTALLATION INSTRUCTIONS

KIT# 523222-4

04/16/2024
RS

ROADMASTER, Inc. 6110 NE 127th Ave. Vancouver, WA 98682 360-896-0407 fax 360-735-9300 www.roadmasterinc.com

20. On each side, insert the removable front arm into the front receiver 90 degrees from its final towing position, depressing the spring-loaded pin against the receiver. Twist back 90 degrees until the spring-loaded pin snaps into place in the notch on the receiver, locking the arm into place in its final towing position. **Please note: It is the owner's responsibility to ensure the locking of the pins before towing. Otherwise, failure of the towing system will result.**

IMPORTANT!

Safety cables are required by law. When towing, connect safety cables to the safety cable tabs illustrated in Figure X. Make certain there is adequate slack in the cables to allow a full turning radius; otherwise, damage will result. If necessary, longer cables or cable extensions are available.



Three options for attaching the wiring plug to the main receiver brace

For six-wire plugs: Use the two supplied 3/4" self-tapping screws to attach the electrical plug directly to the rods on the front of the main receiver brace.

For four-wire round plugs: Attach to the plug mounting plate and then use the two supplied 3/4" self-tapping screws to attach the mounting plate to the rods on the front of the main receiver brace.

For four-wire flat plugs: Place the plug through the mounting plug plate, and then secure it using the supplied zip tie on the front of the plug (Fig.Y). Use the two supplied 3/4" self-tapping screws to attach the mounting plate to the rods on the front of the main receiver brace.

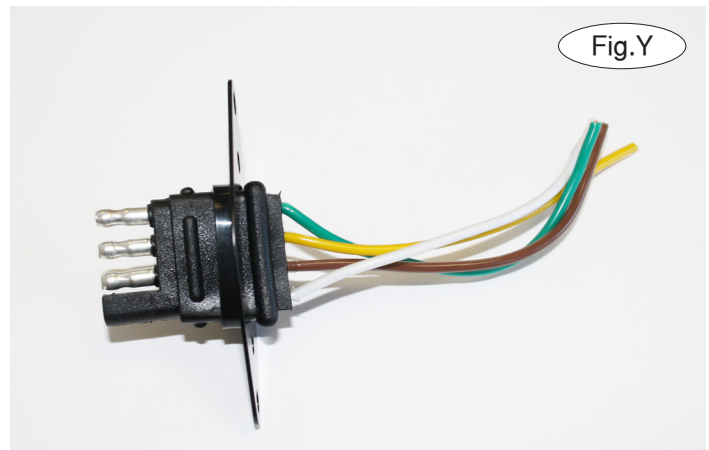

BOLT TORQUE REQUIREMENTS

Note: The torque values represented below are intended as general guidelines. Torque requirements for specific applications may vary. Roadmaster does not warrant this information to be accurate for all applications and disclaims all liability for any claims or damages which may result from its use.

STANDARD BOLTS

Thread Size	Grade	Torque
5/16.....	5.....	13 ft./lb.
3/8.....	5.....	23 ft./lb.
7/16.....	5.....	37 ft./lb.
1/2.....	5.....	56 ft./lb.
5/8.....	5.....	150 ft./lb.

METRIC BOLTS

Thread Size	Grade	Plated / Unplated
8mm-1.0	8.8	20 ft./lb. 18 ft./lb.
8mm-1.25	8.8	19 ft./lb. 18 ft./lb.
10mm-1.25	8.8	38 ft./lb. 36 ft./lb.
10mm-1.5	8.8	37 ft./lb. 35 ft./lb.

METRIC BOLTS

Thread Size	Grade	Plated / Unplated
12mm-1.25	8.8	70 ft./lb. 65 ft./lb.
12mm-1.5	8.8	66 ft./lb. 61 ft./lb.
12mm-1.75	8.8	65 ft./lb. 60 ft./lb.
14mm-2.0	8.8	104 ft./lb. 97 ft./lb.



BASEPLATE KIT INSTALLATION INSTRUCTIONS

KIT# 523222-4

04/16/2024
RS

ROADMASTER, Inc. 6110 NE 127th Ave. Vancouver, WA 98682 360-896-0407 fax 360-735-9300 www.roadmasterinc.com

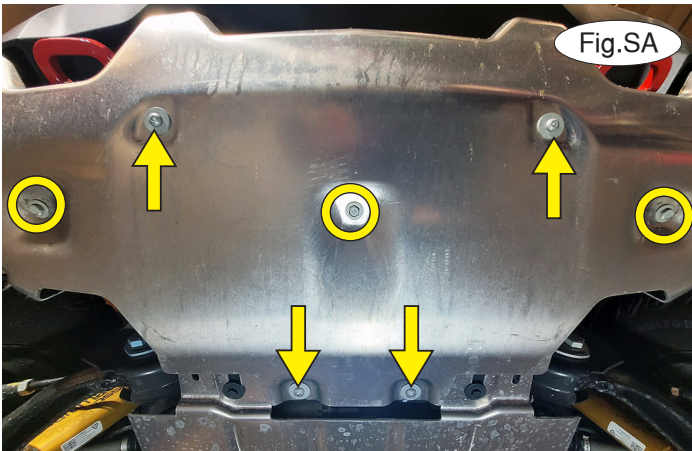

IMPORTANT NOTE: These Steps only apply for the ZR2 model and can be safely ignored otherwise.

S1. After disconnecting the front camera and fog lights, as detailed in step 5, remove four T40 Torx screws (Fig.SA Arrows) and three 13mm bolts (Fig.SA Circles) attaching the bottom skid plate to the frame. Set aside the skid plate for now.

S2. Remove four T15 Torx screws attaching the fascia to the bottom of the bumper core (Fig.SB).



S3. On each side, pull firmly up and out at the seam to release the fascia (Fig.SC). Then, pull up to release the top of the fascia from the retaining pin (Fig.SD). Set aside the fascia for now.

S4. Remove four 13mm bolts attaching the lower rock guard from the bottom bumper core and frame (Fig.SE).

S5. Proceed with steps 9 to 20 as normal, as detailed on page 4.

