



BASEPLATE KIT INSTALLATION INSTRUCTIONS

KIT# 523228-5

10/25
RS

ROADMASTER, Inc.

6110 NE 127th Ave.

Vancouver, WA 98682

360-896-0407

www.RoadmasterInc.com

A second person to help
Flathead screwdriver
T15 Driver
Needle nose pliers
7mm, 10mm, 13mm, 15mm sockets

What You'll Need

10mm wrench
9/16", 3/4" sockets
9/16", 3/4" wrenches
Ratchets
13/32" drill bit

Permanent marker
Reciprocating saw and die grinder
Tape measure
Torque wrench
Threadlocker Red

Need Help? Call Toll-Free

1-800-669-9690

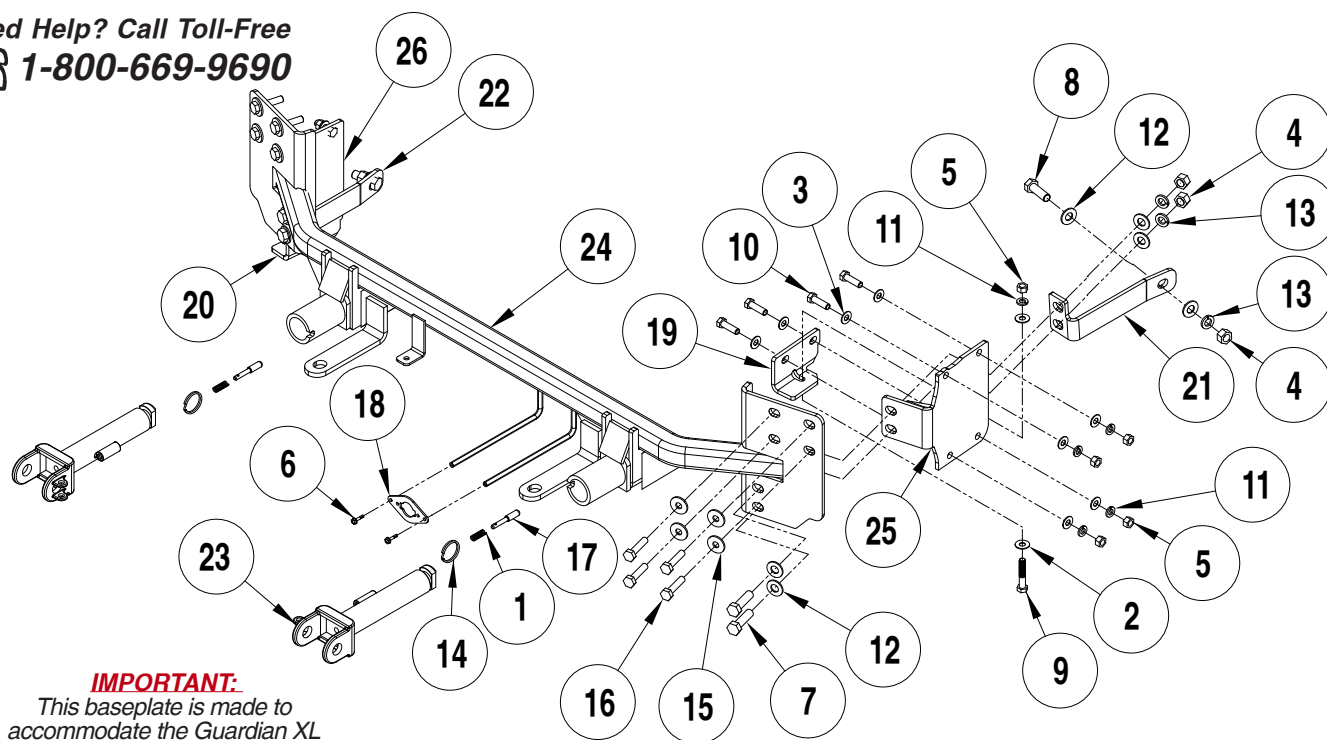

IMPORTANT:

This baseplate is made to accommodate the Guardian XL (#4100). It will not accommodate the Guardian (#4000), some models of the Tow Defender, or StowMaster tow bars.

ITEM..	QTY....	DESCRIPTION.....	PART
1.....	2.....	SPRING.....	200146-00
2.....	4.....	3/8" FLAT WASHER.....	350304-00
3.....	16.....	3/8" SAE WASHER.....	350304-50
4.....	6.....	1/2" HEX NUT.....	350258-00
5.....	10.....	3/8" HEX NUT.....	350254-00
6.....	2.....	#10 x 3/4" SELF DRILLING SCREW.....	350247-35
7.....	4.....	1/2" x 1 3/4" BOLT.....	350096-00
8.....	2.....	1/2" x 1 1/2" BOLT.....	350095-00
9.....	2.....	3/8" x 2" BOLT.....	350059-00
10.....	8.....	3/8" x 1 1/4" BOLT.....	350056-00
11.....	10.....	3/8" LOCK WASHER.....	350305-00
12.....	12.....	1/2" SAE WASHER.....	350308-20
13.....	6.....	1/2" LOCK WASHER.....	350309-00
14.....	2.....	RING.....	350520-00
15.....	8.....	M10 FENDER WASHER.....	355716-00
16.....	8.....	M10 x 1.50 x 45 mm BOLT.....	356104-00
17.....	2.....	LOCK PIN.....	A000008
18.....	1.....	WIRE PLUG PLATE.....	A003801
19.....	1.....	DRIVER SIDE BRACE.....	B003969
20.....	1.....	PASSENGER SIDE BRACE.....	B003970
21.....	1.....	DRIVER SIDE REAR BRACE.....	B004262
22.....	1.....	PASSENGER SIDE REAR BRACE.....	B004263
23.....	2.....	ARM.....	C002383
24.....	1.....	MAIN RECEIVER.....	C003808
25.....	1.....	DRIVER SIDE PLATE.....	C003809
26.....	1.....	PASSENGER SIDE PLATE.....	C003810

All illustrations and specifications contained herein are based on the latest information available at the time of publication approval. ROADMASTER, INC. reserves the right to make changes at any time without notice in material, specification and models or to discontinue models.



BASEPLATE KIT INSTALLATION INSTRUCTIONS

KIT# 523228-5

10/25
RS

ROADMASTER, Inc.

6110 NE 127th Ave.

Vancouver, WA 98682

360-896-0407

www.RoadmasterInc.com

IMPORTANT: All baseplates **must** be assembled with all the bolts left loose for final adjustment and positioning (before tightening) unless otherwise instructed. All bolts **must** be torqued for proper strength. If more than one bolt is used per fastening point, the diagram may only show one. Use flat washers over all slotted holes and lock washers on all fasteners.

WARNING

Failure to heed these warnings or follow the installation instructions may result in a voided warranty, loss of towed vehicle, personal injury or death.

- Do not weld or modify this baseplate or its components. Welding or modification will void the warranty.
- Do not use this document as a basis to design/fabricate a baseplate, as it may not show all parts or structural components.
- We strongly recommend professional installation.
- If the towed vehicle has been in an accident, it must be properly repaired before attaching the baseplate. **Do not install the baseplate if any structural frame damage is found.**
- The installer must use all bolts and parts supplied. If running changes were made by the vehicle manufacturer after this kit was designed, some bolts or other fasteners may no longer be the correct size. **It is the installer's responsibility to verify this kit is securely fastened to the vehicle.**
- Use **Loctite® Red on all bolts used to secure this baseplate.** Torque all bolts to the specifications found at the end of these instructions. Do not over-torque the bolts or failure may occur.
- The installer must inspect the baseplate to ensure adequate clearance, particularly around hoses, air conditioner lines, radiators, etc. or non-warranty failure may result.
- Roadmaster manufactures many styles of baseplates. **If your baseplate has removable arms, they must be removed before driving the vehicle, unless the arms can be pinned or padlocked in place.** If not secured, the arms could vibrate out.
- Some motorhome chassis have such a tight turning radius that you can damage your motorhome, towed vehicle, tow bar or baseplate while turning sharply. **Before getting on the road, test your turning radius in an empty parking lot.** Turning too sharply could

result in non-warranty damage to your towing system, motorhome and/or towed vehicle.

- Do not back up with the towed vehicle attached or non-warranty damage will occur to your towing system or vehicles.
- The safety cables must connect the towing vehicle to the towed vehicle frame to frame, with the cables crossed, with enough slack for sharp turns. See cable instructions for proper routing. Failure to do so will result in non-warranty damage and/or the loss of the towed vehicle.
- This kit is designed for use with ROADMASTER tow bars and ROADMASTER adapters only. **Using this kit with other brands, without an approved ROADMASTER adapter, may result in non-warranty damage or injury.**
- Receiver extensions and out-of-level towing situations of 3 inches or more. This can cause the system to swing much higher and lower, causing excessive strain on the tow bar, baseplate and frame. That can cause the towing system to fail, causing property damage, personal injury or even death. **If you must use a receiver extension or drop hitch to tow, it will reduce your receiver's weight capacity by 1/3 to avoid damaging your system. Never use more than one extension and/or drop hitch, as this will void your warranty.**
- Every 3,000 miles, the owner must inspect all mounting points for cracks or fatigue, and check the fasteners for proper torque, according to the bolt torque requirements chart on the last page of these instructions.
- The owner must follow the vehicle manufacturer's instructions to prepare the vehicle for towing. Failure to do so may cause severe damage to the vehicle.
- This baseplate is only warranted for the original installation. Installing a used baseplate on another vehicle is not recommended and will void the warranty.

About this kit:

This is one of our direct connect-style series, which allows the visible front portion of the baseplate to be easily removed from the front of the vehicle (Fig.A and Fig.B).

This kit consists of a main receiver brace, two rear support braces, two removable front braces, and a hardware pack.

The main receiver brace mounts to the frame and side braces on each side. The removable front braces install in the main receiver braces.

Before starting the installation, lay out the kit components in order, as they will be used. This will give you a visual idea of how the components work, and will also confirm that everything is present and accounted for.



Fig.A



Fig.B



BASEPLATE KIT INSTALLATION INSTRUCTIONS

KIT# 523228-5

10/25
RS

ROADMASTER, Inc.

6110 NE 127th Ave.

Vancouver, WA 98682

360-896-0407

www.RoadmasterInc.com

Important: Please use all supplied hardware and read through these instructions carefully before beginning this installation. The majority of questions you may have can be answered within the text, and proper installation will ensure safe and secure travel.

1. Remove six T15 screws from the top of the fascia then remove one plastic clip attaching the washer bottle to the fascia and frame (Fig.C and Inset). *Note: Disconnect the car battery before proceeding.*

2. Remove six T15 screws on each side (Circles), six 7mm screws on the passenger side, five 7mm screws on the driver side (Triangles), two plastic clips on the passenger side, as well as one plastic clip on the drivers side (Arrows) from the bottom and sides of the fascia attaching it to the sub-frame (Fig.D).

3. On each side, remove the flat small plastic cover that is attached on the bottom of the fascia and the sub-frame (Fig.E).

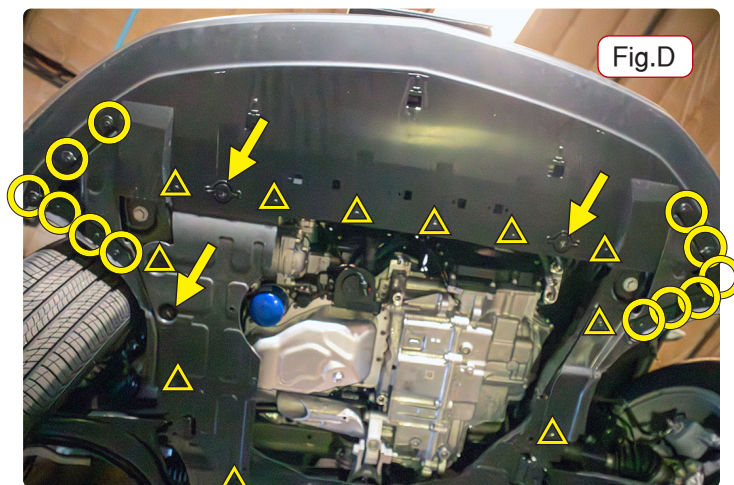
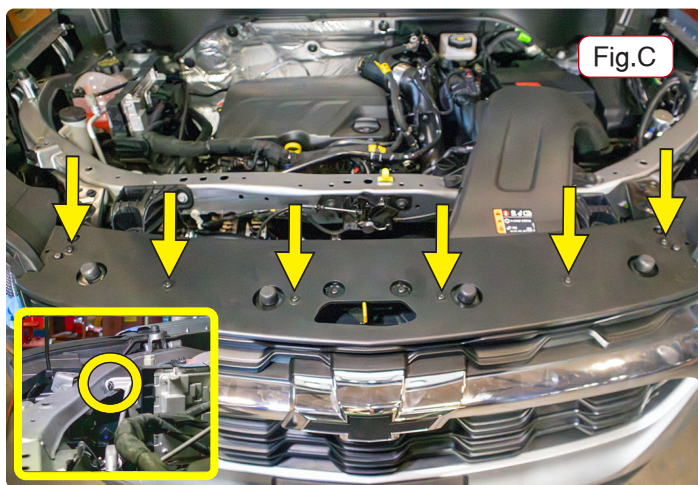

4. Remove a small plastic plate attached to the sub-frame on the passengers side (Fig.F).

5. On each side, remove three T15 screws and one plastic clip that is attaching the fender wall to the fascia (Fig.AB).

6. On each side, pull the inner fender liner up and out, careful to not fully remove it.

7. On the drivers side, un-clip the ambient temp sensor from the sub-frame wall then uncouple the ambient temp sensor array wiring to detach it from the fascia (Fig.G & Inset, Next Page).





BASEPLATE KIT INSTALLATION INSTRUCTIONS

KIT# 523228-5

10/25
RS

ROADMASTER, Inc.

6110 NE 127th Ave.

Vancouver, WA 98682

360-896-0407

www.RoadmasterInc.com

8. Starting with the drivers side before proceeding to the passengers side, locate the front of the fender trim. Starting from the front of the fender trim, un-clip several of the plastic clips attaching the trim to the fascia, only remove enough until you can access the 7mm screw holding the fascia to the fender which is located on the top of the wheelhouse. Use a soft rag to carefully hold the trim in place. Remove this bolt. Use an 8mm socket from behind the clips can help un-clip them without breaking them (Fig.H and Inset).

9. On each side, remove two 13mm bolts from the sides of the lower sub-frame that are attached to the fascia (Fig.I).

10. Pop up the plastic plate on the top of the fascia and then, with the help of a second person, lift up and then out on the fascia to remove it from the sub-frame (Fig. J).



Fig.G



Fig.H



Fig.I



Fig.J

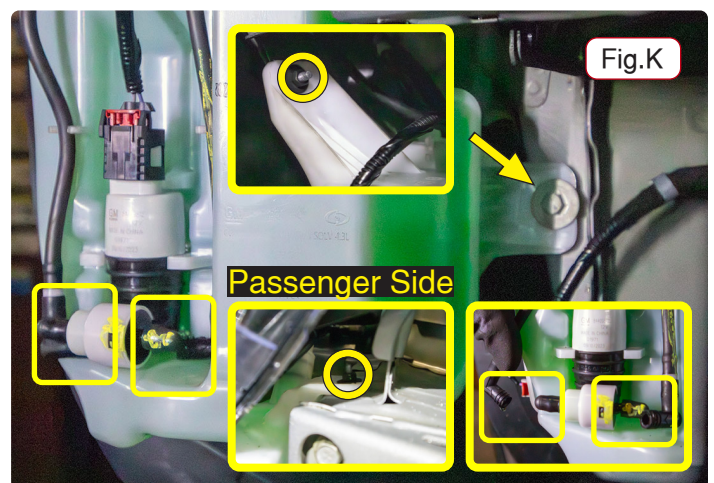

Fig.K

11. On the passenger side, remove one 10mm bolt from the wiper fluid assembly (Fig.K – Arrow) then remove two 10mm nuts (Fig.K – Circles) from the upper inner side of the assembly. Proceed to then disconnect both wires attached to the assembly, disconnect the two pipes leading into the fluid reservoir and cap them off (Fig.K and Insets). Move the wires and pipes so they are out of the way.

12. On each side, remove one clip from the top and one from the bottom of the inner cooler cover, then remove the cover,



BASEPLATE KIT INSTALLATION INSTRUCTIONS

KIT# 523228-5

10/25
RS

ROADMASTER, Inc.

6110 NE 127th Ave.

Vancouver, WA 98682

360-896-0407

www.RoadmasterInc.com

it will not be replaced (Fig.L and Inset).

13. Remove three 10mm bolts attaching the three brackets to the bumper core (Fig.M).

14. On each side remove one plastic clip on top of the bumper core. (Fig.N – insets) Then on each side remove four 15mm bolts attaching the bumper core to the sub frame, set aside for now (Fig.N).

15. On the passenger side, unclip two plastic clips attaching the identified wire to the lower cooler, unclip the wire from it's mount (Fig.O).

16. As indicated in figure P1 & P2 and insets, trim the inner cooler housing as shown.

17. On the driver side, unclip the sensor harness, using some sort of bungee cord or rope to secure the harness back away from the fascia temporarily (Fig.Q, Next Page)

18. Based off the front page diagram, identify the driver's side plate. Using the brace as a guide, align these two edges

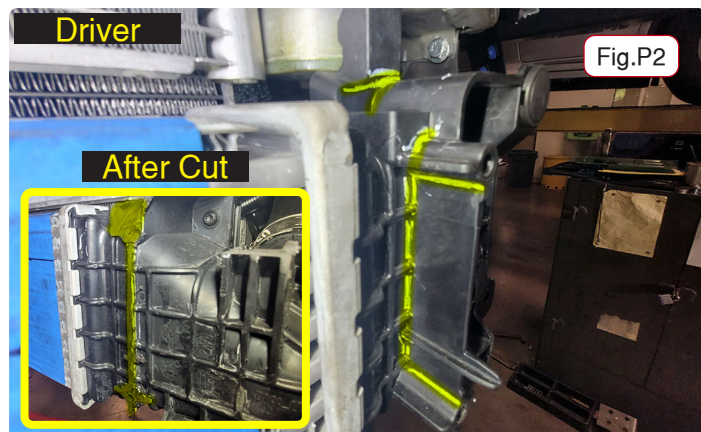
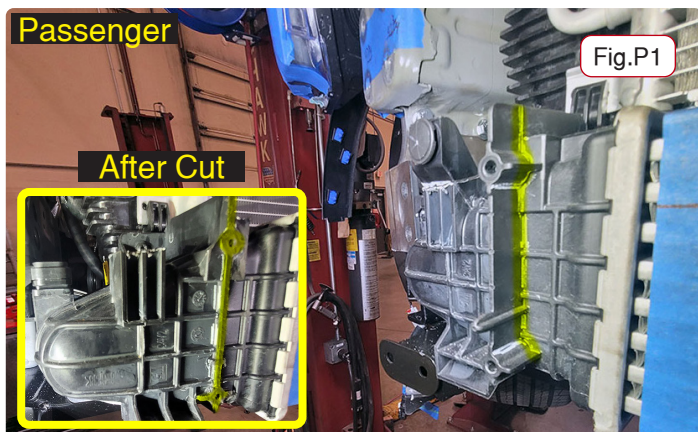
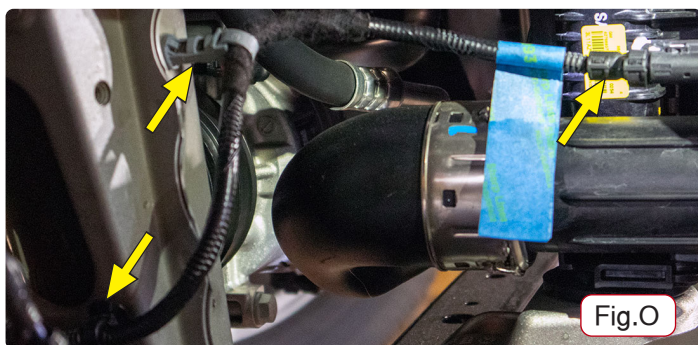
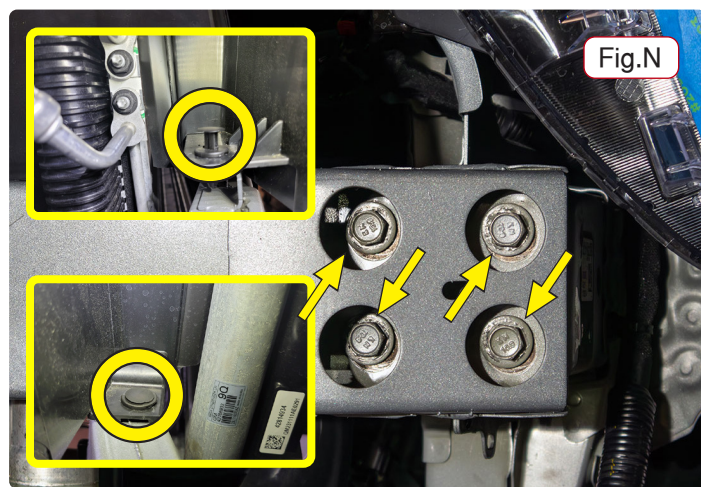
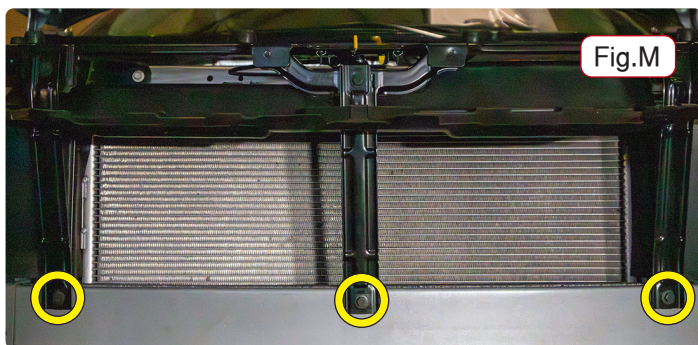
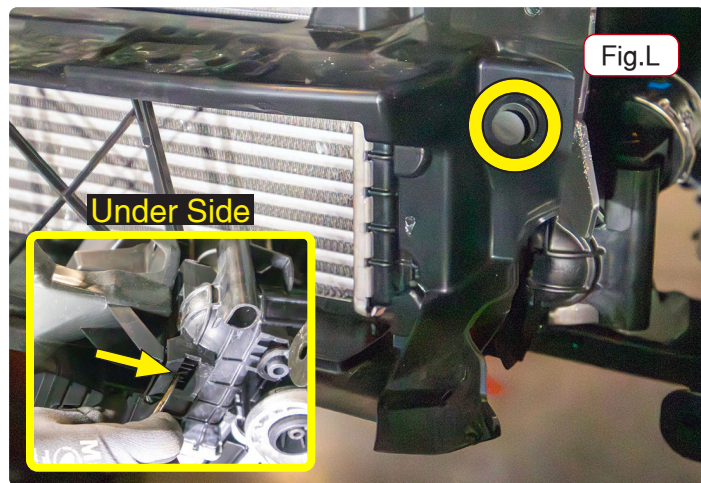



BASEPLATE KIT INSTALLATION INSTRUCTIONS

KIT# 523228-5

10/25
RS

ROADMASTER, Inc.

6110 NE 127th Ave.

Vancouver, WA 98682

360-896-0407

www.RoadmasterInc.com

(Highlighted in Fig.R) to the top front of the sub frame extension horn seam weld edge, mark the two holes with paint or a marker, then drill out the seam weld / pinch weld using a 13/32" drill bit (Fig.R and Inset).

19. For the next few steps, reference Diagram 2 on the next page for order of installation. Then attach the driver's side plate to the newly drilled holes using two 3/8" x 1-1/4" bolts, 3/8" SAE washer and finish on the other side with a 3/8" SAE washer, lock washer, and nut. Finger tighten for now (Fig.S).

20. Based off the front page diagram, identify the driver's side brace (Item 19). Use a 3/8" x 1-1/4" bolts, 3/8" SAE washer and finish on the other side with a 3/8" SAE washer, lock washer, and nut. (Fig.T). Finger tighten for now.

21. Using a supplied 3/8" x 2" bolt with a 3/8" flat washer bolt up through subframe then side brace (Fig.T – Inset), then finish with a 3/8" flat washer lock washer and nut (Fig.U). Passenger side shows finished install.

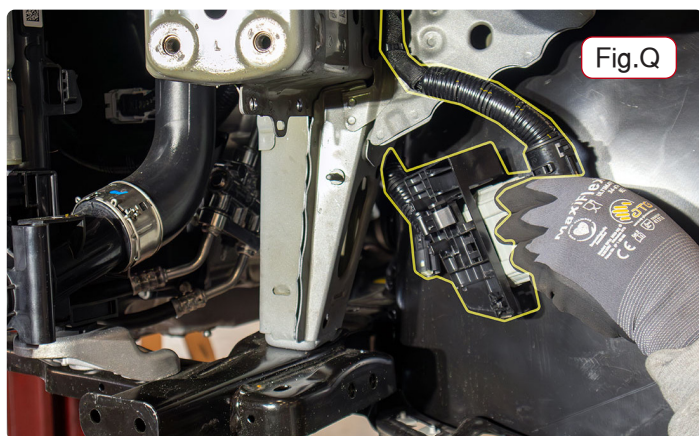

Fig.Q

22. Ream out the holes in the bumper core slightly, as indicated in Figure V on next page.

23. Loosely, for now, reattach the bumper core to the sub frame at the three bracket points it was removed from earlier (Fig.W, Next Page).

24. With the help of a second person, align the main receiver baseplate (Item 25) to the sub frame then slide it up and into position behind the bumper core (Fig.X, Next Page).

25. On each side, then use four 10mm x 1.5mm x 45mm bolts with lock washer and 10mm x 30mm fender washer to secure the main receiver baseplate into position. Finger tighten for now.

26. Working on the drivers side, referencing front page diagram, locate the driver side rear brace; using a 1/2" x 1-1/2" bolt with a 1/2" SAE washer bolt through the driver side rear brace into the lower rear sub-frame. Then finish with a 1/2" SAE washer, 1/2" lock washer, and 1/2" nut. Leave finger tight for now then do the passenger's side (Fig.Y and Inset, next Page).

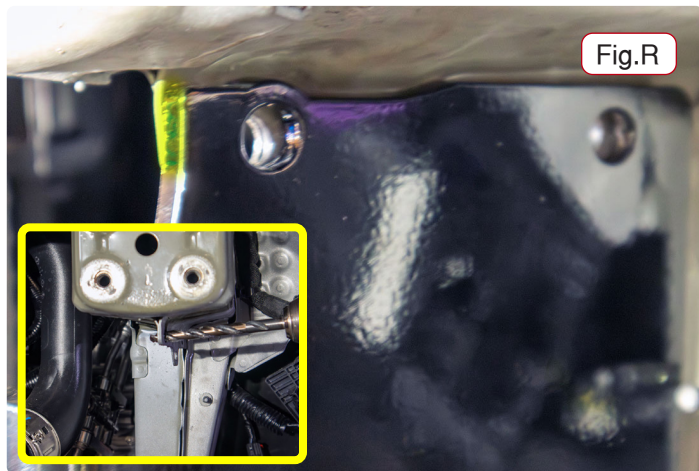

Fig.R

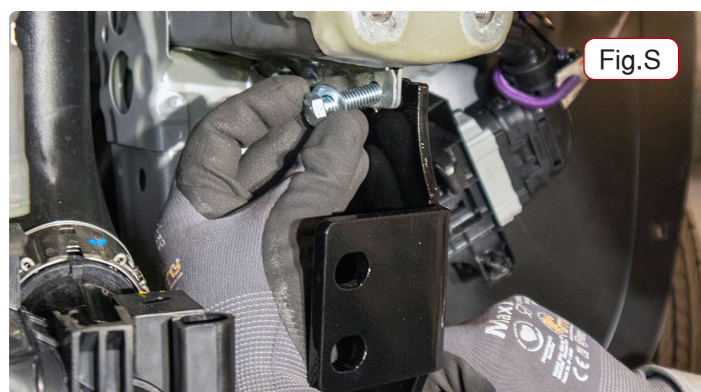

Fig.S



Fig.T

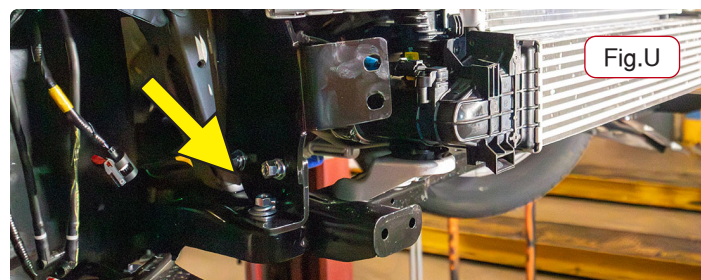

Fig.U



BASEPLATE KIT INSTALLATION INSTRUCTIONS

KIT# 523228-5

10/25
RS

ROADMASTER, Inc.

6110 NE 127th Ave.

Vancouver, WA 98682

360-896-0407

www.RoadmasterInc.com

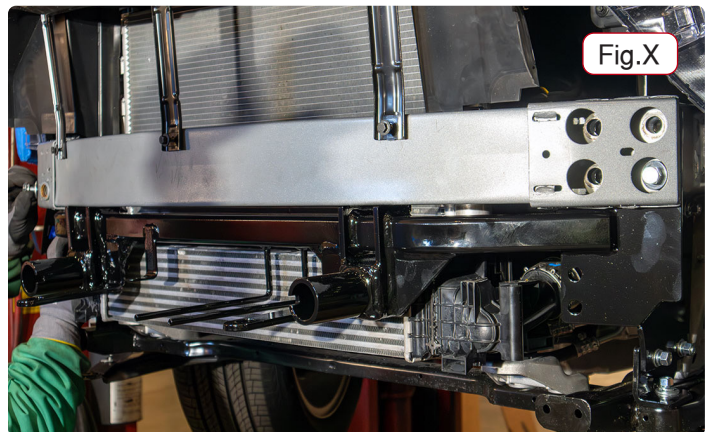
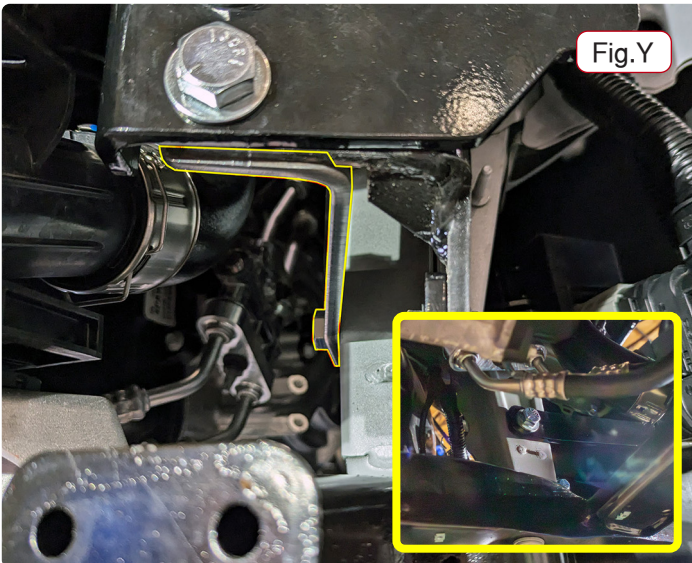
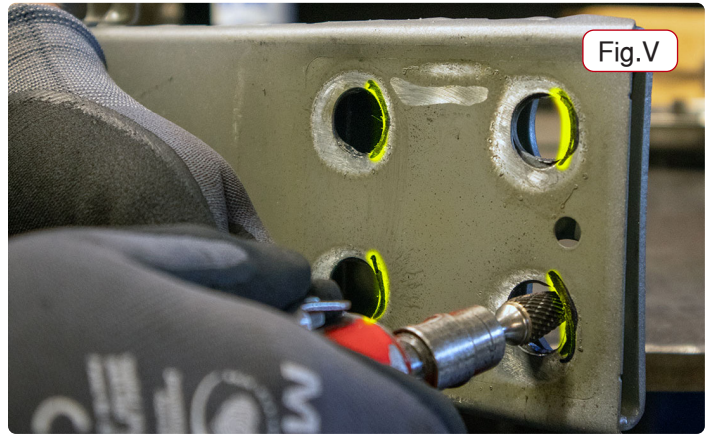
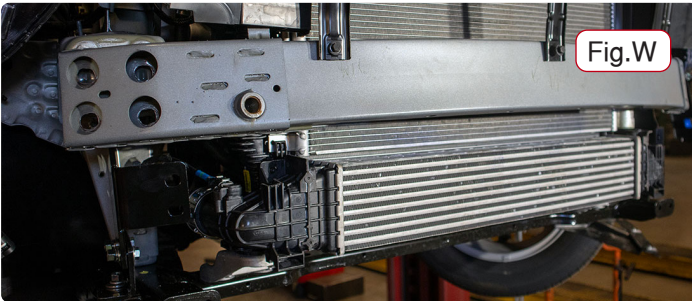
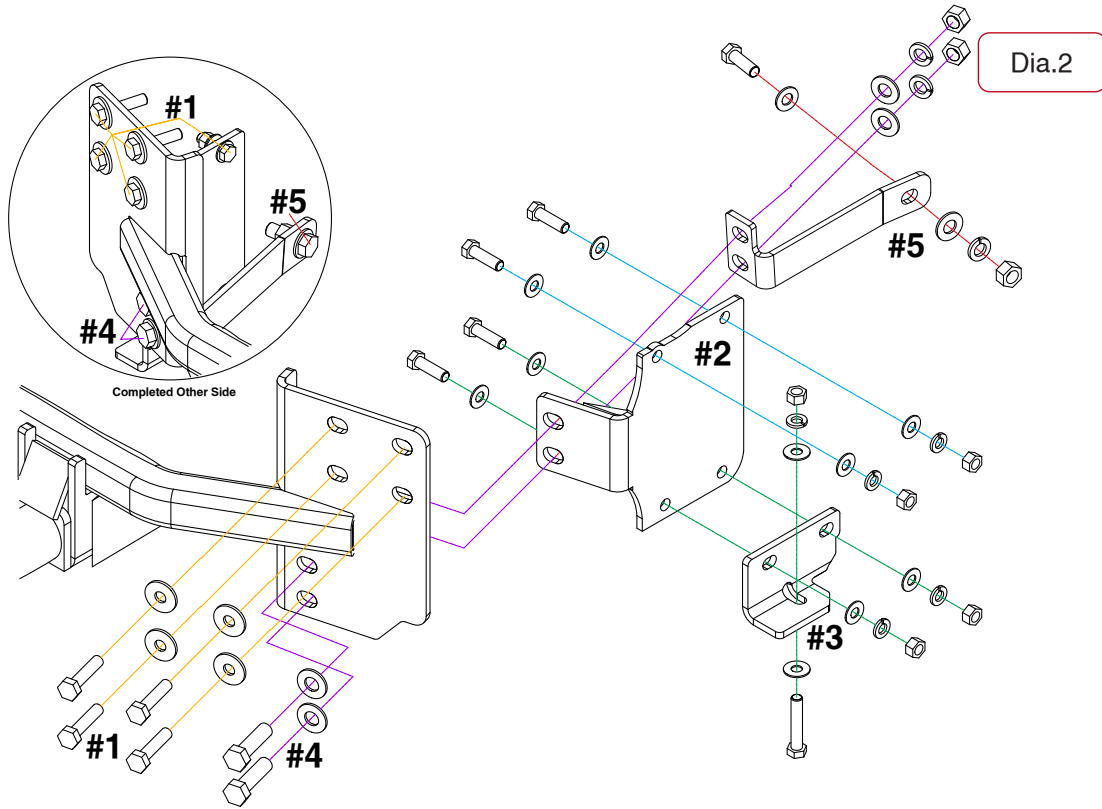



BASEPLATE KIT INSTALLATION INSTRUCTIONS

KIT# 523228-5

10/25
RS

ROADMASTER, Inc.

6110 NE 127th Ave.

Vancouver, WA 98682

360-896-0407

www.RoadmasterInc.com

27. Then on each side using the provided 1/2" x 1-3/4" bolt with a 1/2" SAE washer. Bolt through the main receiver, side plate, rear brace and finish with 1/2" SAE washer, 1/2" lock washer and 1/2" nut. (Fig.Z) Finger tighten for now.

28. Tighten the bumper core bolts then tighten the lower rear support brace bolts.

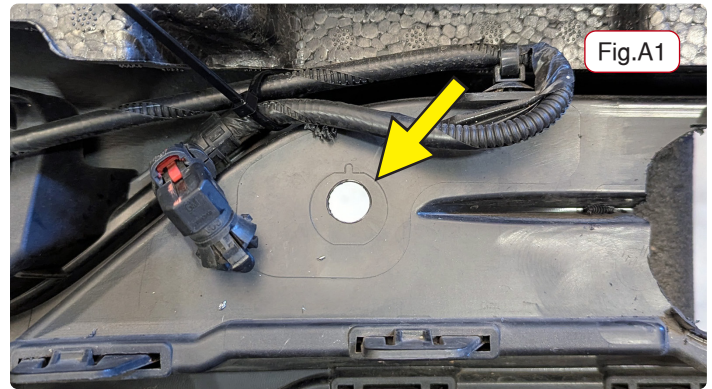

29. If you are using our breakaway, mount it now.

30. If you are using our wireplug, mount the bracket and it at this time.

31. Tighten all nuts and bolts to specification at end of document. Use Red Threadlocker on all nuts and bolts!

32. The ambient air temperature sensor on the driver's side, along the interior of the fascia, must be moved so that it is not blocked by the baseplate. Drill a small 1/2" hole and relocate the air sensor (as indicated in Fig.A1), if a block heater is present, move the sensor so that it does not conflict with either heater or baseplate. Fig.A2 shows before and Fig.A3 shows after.

33. Trim the inner panel of the fascia to allow for access to the baseplate (Fig.B1 and B2)

34. Reverse steps 18 backwards to reattach the fascia and other critical components to the frame.

Important: Please note, it is the owner's responsibility to ensure the locking of the pins before towing. Otherwise, failure of the towing system will result.

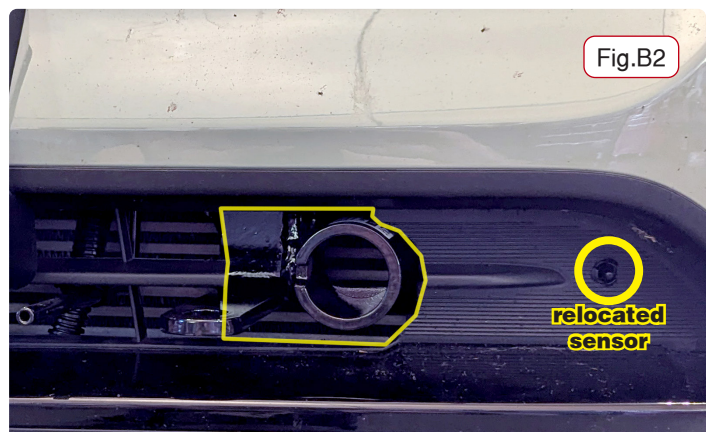
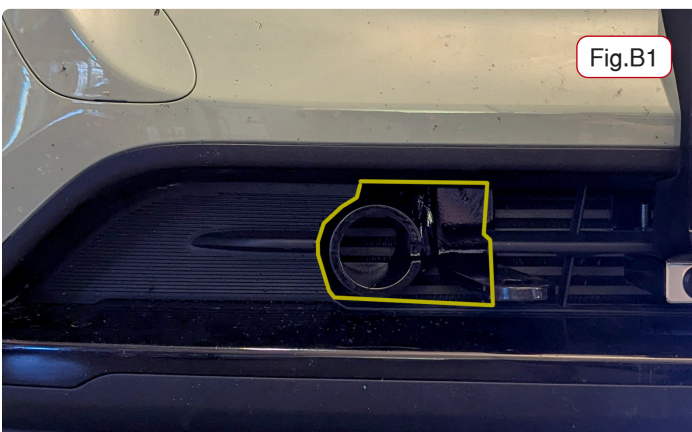



BASEPLATE KIT INSTALLATION INSTRUCTIONS

KIT# 523228-5

10/25
RS

ROADMASTER, Inc.

6110 NE 127th Ave.

Vancouver, WA 98682

360-896-0407

www.RoadmasterInc.com

IMPORTANT!

Safety cables are required by law. When towing, connect safety cables to the safety cable tabs illustrated on the separate insert with the drawing and parts list and in Figure AA. Make certain there is adequate slack in the cables to allow a full turning radius; otherwise, damage will result. If necessary, longer cables or cable extensions are available.

WARNING!

If you do not use Threadlocker Red on all bolts in this kit and torque to the specified values, it could cause failure of the towing system.



Three options for attaching the wiring plug to the main receiver brace:

For six-wire plugs: Use the two supplied 3/4" self-tapping screws to attach the electrical plug directly to the rods on the front of the main receiver brace.

For four-wire round plugs: Attach to the plug mounting plate and then use the two supplied 3/4" self-tapping screws to attach the mounting plate to the rods on the front of the main receiver brace.

For four-wire flat plugs: Place the plug through the mounting plug plate, and then secure it using the supplied zip tie on the front of the plug (Adjacent Figure). Use the two supplied 3/4" self-tapping screws to attach the mounting plate to the rods on the front of the main receiver brace.

Plug may need to be pushed in and down to meet clearance.

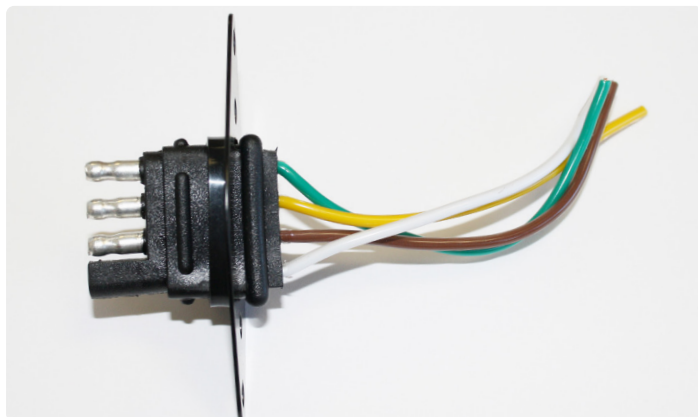

BOLT TORQUE REQUIREMENTS

Note: The torque values represented below are intended as general guidelines. Torque requirements for specific applications may vary. Roadmaster does not warrant this information to be accurate for all applications and disclaims all liability for any claims or damages which may result from its use.

STANDARD BOLTS

Thread Size	Grade	Torque
5/16-18	5	13 ft./lb.
3/8-16	5	23 ft./lb.
7/16-14	5	37 ft./lb.
1/2-13	5	57 ft./lb.
5/8-11	5	112 ft./lb.

METRIC BOLTS

Thread Size	Grade	Torque
6mm-1.0	8.8	6 ft./lb.
8mm-1.0	8.8	18 ft./lb.
8mm-1.25	8.8	16 ft./lb.
10mm-1.25	8.8	36 ft./lb.
10mm-1.5	8.8	31 ft./lb.

METRIC BOLTS

Thread Size	Grade	Torque
12mm-1.25	8.8	64 ft./lb.
12mm-1.5	8.8	60 ft./lb.
12mm-1.75	8.8	55 ft./lb.
14mm-2.0	8.8	88 ft./lb.