



BASEPLATE KIT INSTALLATION INSTRUCTIONS

KIT# 524423-1

08/31/10
KS

ROADMASTER, Inc. 6110 NE 127th Ave. Vancouver, WA 98682 360-896-0407 fax 360-735-9300 www.roadmasterinc.com

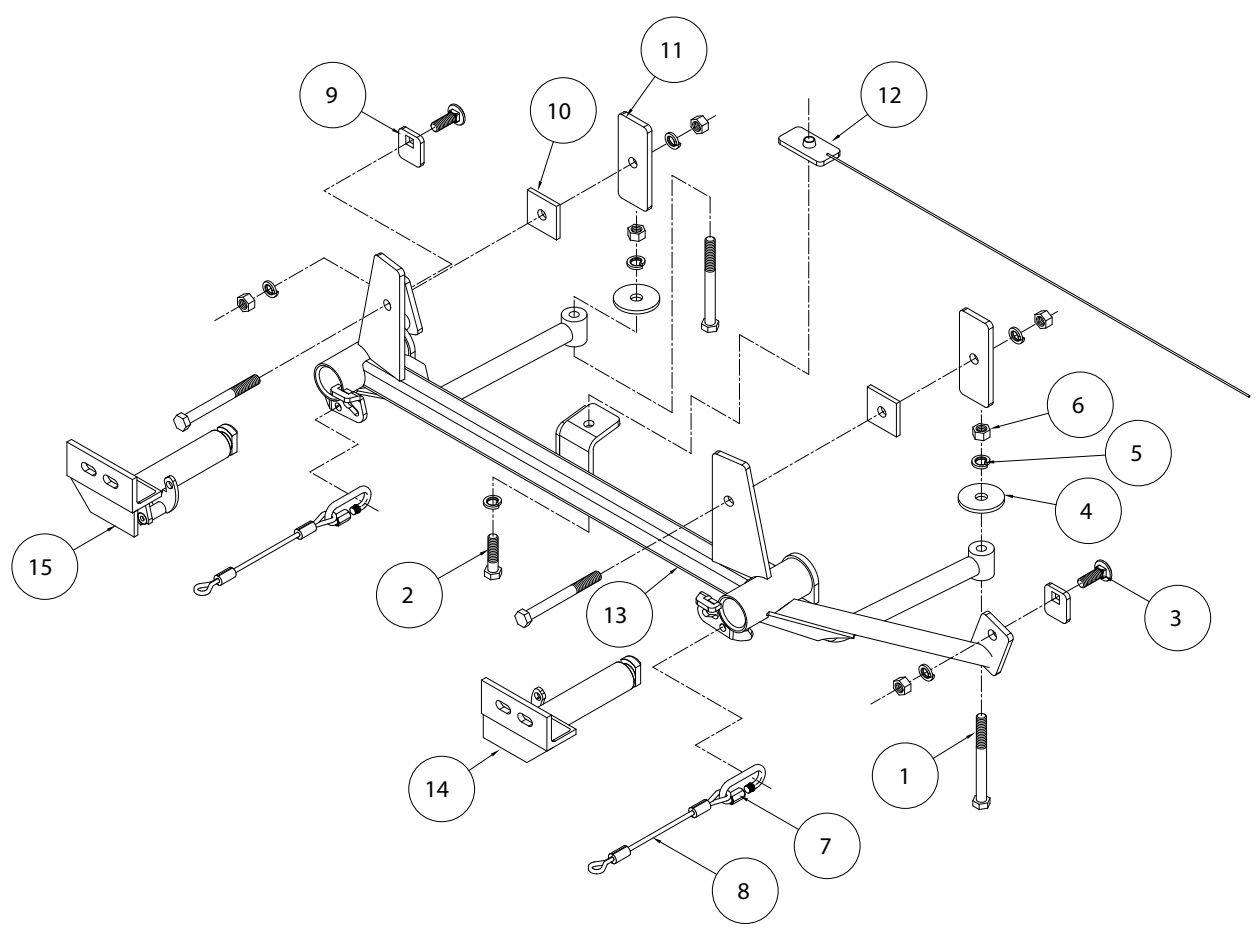

ITEM	QTY	NAME	MATERIAL
1	4	1/2" x 5" BOLT	350107-00
2	1	1/2" x 2" BOLT	350097-00
3	2	1/2" x 1 1/2" CARRIAGE BOLT	350362-00
4	2	1/2" PLATE WASHER	A-003086
5	7	1/2" LOCK WASHER	350309-00
6	6	1/2" HEX NUT	350258-00
7	2	QUICK LINK	200008-00
8	2	SAFETY CABLE 8"	650646-08
9	2	1/4" x 1 1/2" x 1 3/4" SQUARE HOLE BACKING PLATE	A-002885
10	2	5/16" x 2" x 2" BACKING PLATE	A-003113
11	2	5/16" x 2" x 5" BACKING PLATE	A-002888
12	1	3/16" x 1 1/2" x 3" THREADED BACKING PLATE W/ ROD	C-001841
13	1	MAIN RECEIVER	C-001982
14	1	DRIVER SIDE ARM	C-001983
15	1	PASSENGER SIDE ARM	C-001984



BASEPLATE KIT INSTALLATION INSTRUCTIONS

KIT# 524423-1

08/31/10
KS

ROADMASTER, Inc. 6110 NE 127th Ave. Vancouver, WA 98682 360-896-0407 fax 360-735-9300 www.roadmasterinc.com

This is one of our EZ2 series brackets, which allows the visible front portion of the bracket to be easily removed from the front of the vehicle (Fig.A and Fig.B). The bracket consists of a main receiver brace, two removable front braces, and a hardware pack.

The main receiver brace mounts to the frame rails and the bumper core. The removable front braces install in the main receiver brace.

Before starting the installation, lay out the kit components in order, as they will be used. This will give you a visual idea of how the components work, and will also confirm that everything is present and accounted for.



IMPORTANT: All baseplates **must** be assembled with all the bolts left loose for final adjustment and positioning (before tightening) unless otherwise instructed. All bolts **must** be torqued for proper strength. If more than one bolt is used per fastening point, the diagram may only show one. Use flat washers over all slotted holes and lock washers on all fasteners.

WARNING

Failure to heed these warnings or follow the installation instructions may result in a voided warranty, loss of towed vehicle, personal injury or death.

- Do not weld or modify this baseplate or its components. Welding or modification will void the warranty.
- Do not use this document as a basis to design/fabricate a baseplate, as it may not show all parts or structural components.
- We strongly recommend professional installation.
- If the towed vehicle has been in an accident, it must be properly repaired before attaching the baseplate. Do not install the baseplate if any structural frame damage is found.
- The installer must use all bolts and parts supplied. If running changes were made by the vehicle manufacturer after this kit was designed, some bolts or other fasteners may no longer be the correct size. It is the installer's responsibility to verify this kit is securely fastened to the vehicle.
- Use Loctite® Red on all bolts used to secure this baseplate. Torque all bolts to the specifications found at the end of these instructions. Do not over-torque the bolts or failure may occur.
- The installer must inspect the baseplate to ensure adequate clearance, particularly around hoses, air conditioner lines, radiators, etc. or non-warranty failure may result.
- Roadmaster manufactures many styles of baseplates. If your baseplate has removable arms, they must be removed before driving the vehicle, unless the arms can be pinned or padlocked in place. If not secured, the arms could vibrate out.
- Some motorhome chassis have such a tight turning radius that you can damage your motorhome, towed vehicle, tow bar or baseplate while turning sharply. Before getting on the road, test your turning radius in an empty parking lot. Turning too sharply could result in non-warranty damage to your towing system, motorhome and/or towed vehicle.
- Do not back up with the towed vehicle attached or non-warranty damage will occur to your towing system or vehicles.
- The safety cables must connect the towing vehicle to the towed vehicle frame to frame, with the cables crossed, with enough slack for sharp turns. See cable instructions for proper routing. Failure to do so will result in non-warranty damage and/or the loss of the towed vehicle.
- This kit is designed for use with ROADMASTER tow bars and ROADMASTER adapters only. Using this kit with other brands, without an approved ROADMASTER adapter, may result in non-warranty damage or injury.
- Receiver extensions and out-of-level towing situations of 3 inches or more. This can cause the system to swing much higher and lower, causing excessive strain on the tow bar, baseplate and frame. That can cause the towing system to fail, causing property damage, personal injury or even death. If you must use a receiver extension or drop hitch to tow, it will reduce your receiver's weight capacity by 1/3 to avoid damaging your system. Never use more than one extension and/or drop hitch, as this will void your warranty.
- Every 3,000 miles, the owner must inspect all mounting points for cracks or fatigue, and check the fasteners for proper torque, according to the bolt torque requirements chart on the last page of these instructions.
- The owner must follow the vehicle manufacturer's instructions to prepare the vehicle for towing. Failure to do so may cause severe damage to the vehicle.
- This baseplate is only warranted for the original installation. Installing a used baseplate on another vehicle is not recommended and will void the warranty.



BASEPLATE KIT INSTALLATION INSTRUCTIONS

KIT# 524423-1

08/31/10
KS

ROADMASTER, Inc. 6110 NE 127th Ave. Vancouver, WA 98682 360-896-0407 fax 360-735-9300 www.roadmasterinc.com



1. **Important:** please use all supplied bolts and parts and read all instructions carefully before beginning this installation. The majority of questions you may have can be answered within the text, and proper installation will ensure safe and secure travel. Now, begin the installation. Remove four 10mm (head) screws and two plastic fasteners attaching the top of the fascia to the core support (Fig.C).

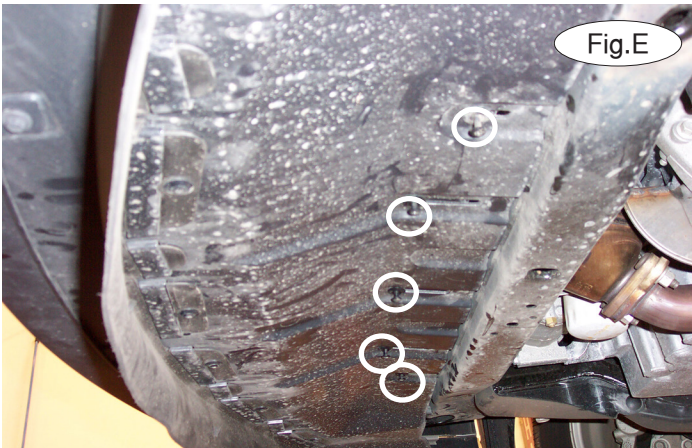

2. On each side, remove three Phillips screws, one 8mm (head) screw and one plastic fastener attaching the fender liner to the fascia (Fig.D – driver's side).

3. Remove five plastic fasteners attaching the front of the center splash shield to the radiator support (Fig.E).

4. Pull out and forward on the corners of the fascia to remove it (Fig.F). Disconnect the side marker lights.

5. On each side, trim the air deflector using the yellow lines in Figure G as a guide for trimming.

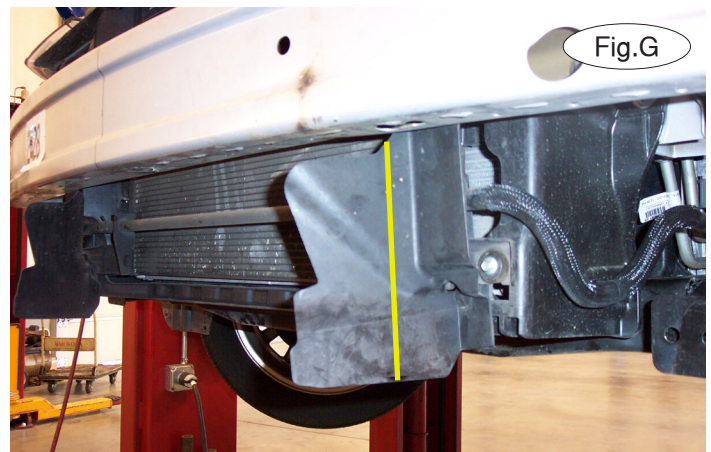



BASEPLATE KIT INSTALLATION INSTRUCTIONS

KIT# 524423-1

08/31/10
KS

ROADMASTER, Inc. 6110 NE 127th Ave. Vancouver, WA 98682 360-896-0407 fax 360-735-9300 www.roadmasterinc.com

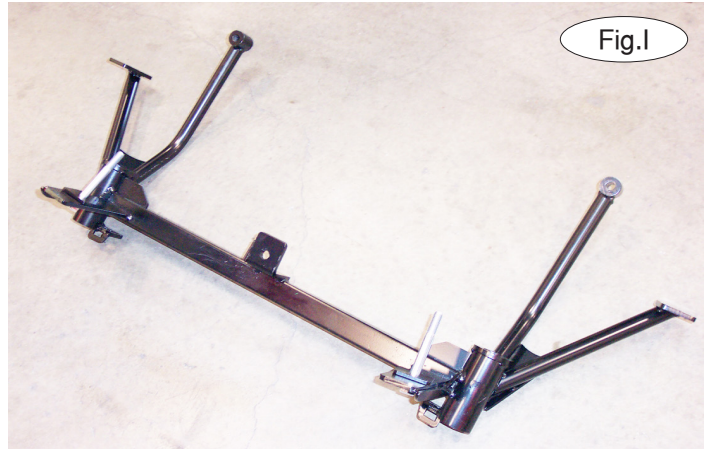
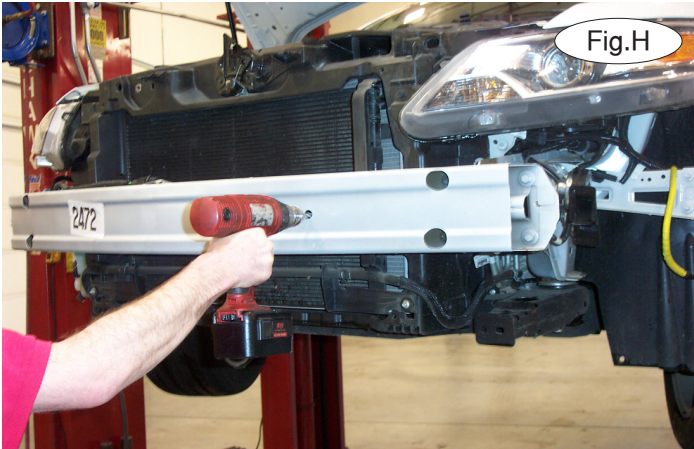

6. Locate the two pre-existing holes in the bumper core. Using a $\frac{1}{2}$ " bit, drill straight through the two holes and through the back of the bumper core (Fig.H). If you have difficulty drilling through the back of the bumper core, drill a pilot hole first. *Note:* use caution and a metal plate to avoid drilling into engine components.

7. Using the two supplied $\frac{1}{2}$ " x 5" bolts, bolt through the upper mounting points on the main receiver brace. Place a $\frac{1}{4}$ " x $2\frac{1}{2}$ " backing plate over each bolt (Fig.I). Mount the main receiver brace to the bumper core (Fig.J).

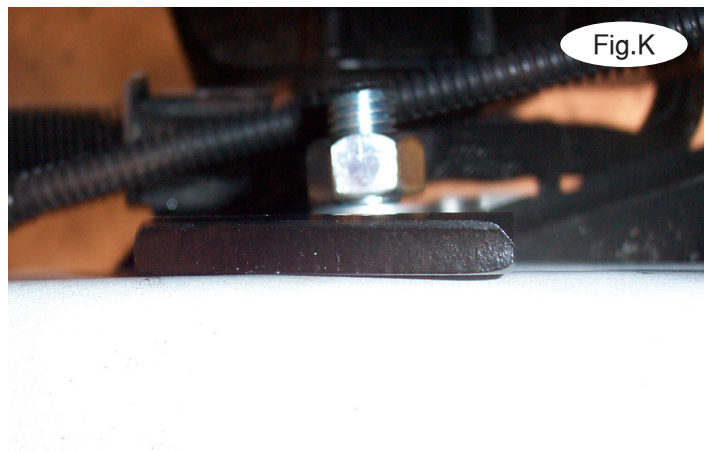

8. On each side, place a 2" x 5" backing plate over the $\frac{1}{2}$ " bolt you installed in the previous step, and bolt into place using a $\frac{1}{2}$ " lock washer and nut (Fig.K).



BASEPLATE KIT INSTALLATION INSTRUCTIONS

KIT# 524423-1

08/31/10
KS

ROADMASTER, Inc. 6110 NE 127th Ave. Vancouver, WA 98682 360-896-0407 fax 360-735-9300 www.roadmasterinc.com

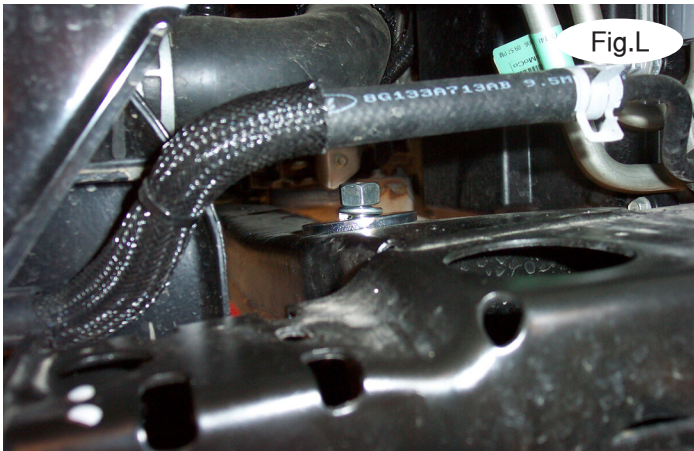

9. On each side, using a $\frac{1}{2}$ " x 5" bolt, bolt from the bottom up through the lower mounting point of the main receiver brace and the pre-existing holes in the top and bottom of the subframe (Fig.L). Place a $\frac{1}{2}$ " plate washer on top of the bolt, and finish with a lock washer and nut (Fig.M).

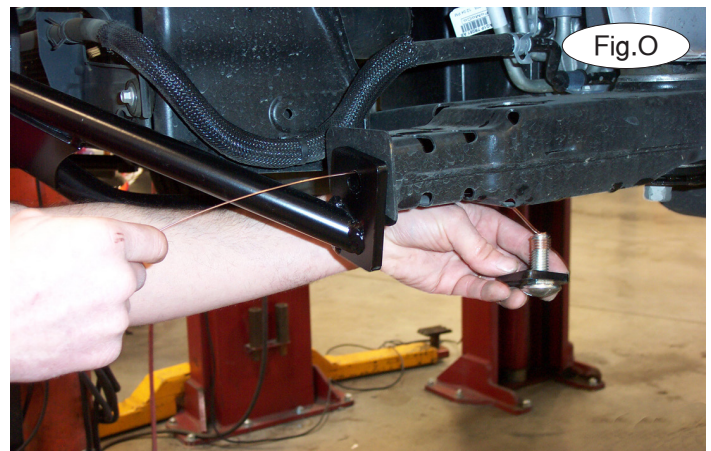

10. On each side, using the hole in the main receiver brace as a template, enlarge the the pre-existing hole in the end of the frame rail (Fig.N – driver's side).

11. Place a $\frac{1}{2}$ " x $1\frac{1}{2}$ " carriage bolt through the $\frac{1}{4}$ " x $1\frac{1}{2}$ " x $1\frac{3}{4}$ " backing plate and fishwire it through the large, pre-existing opening in the bottom of the subframe, into the subframe and into the main receiver brace (Fig.O).

12. Using the center mounting point of the main receiver brace as a template, drill a $\frac{1}{2}$ " hole through the bottom of the bumper core (Fig.P).





BASEPLATE KIT INSTALLATION INSTRUCTIONS

KIT# 524423-1

08/31/10
KS

ROADMASTER, Inc. 6110 NE 127th Ave. Vancouver, WA 98682 360-896-0407 fax 360-735-9300 www.roadmasterinc.com

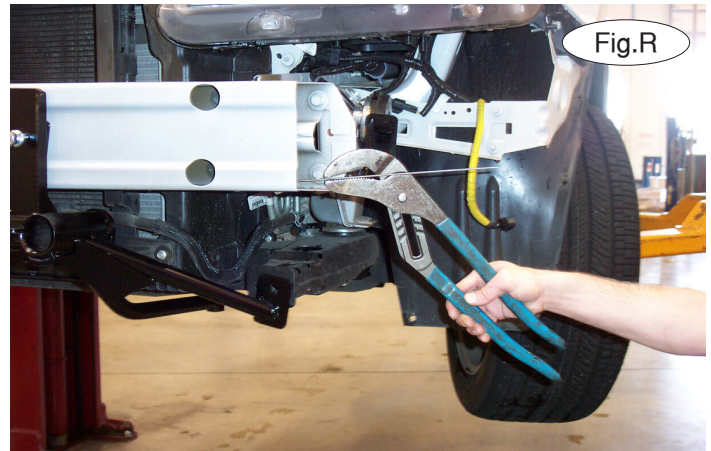
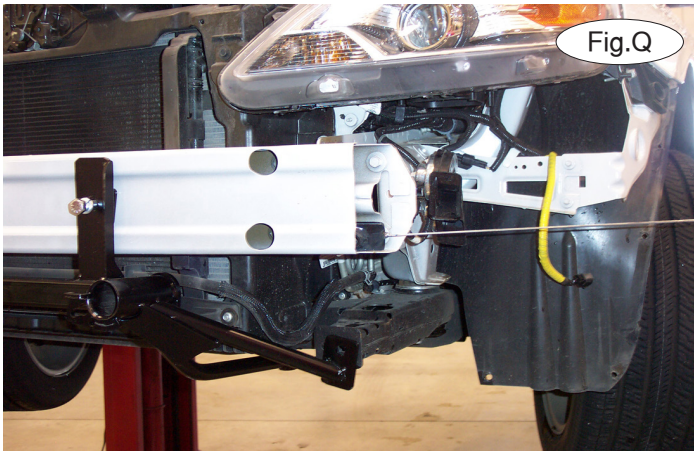

13. Place the $\frac{1}{4}$ " x $1\frac{1}{2}$ " x 3" backing plate with wire inside the frame over the center mounting point of the main receiver brace (Fig.Q). Using the supplied $\frac{1}{2}$ " x $1\frac{1}{2}$ " bolt and $\frac{1}{2}$ " lock washer, bolt up through the bumper core and into the backing plate with wire. Using a pair of pliers, break off the wire (Fig.R).

14. Tighten all bolts to the bolt torque requirements.

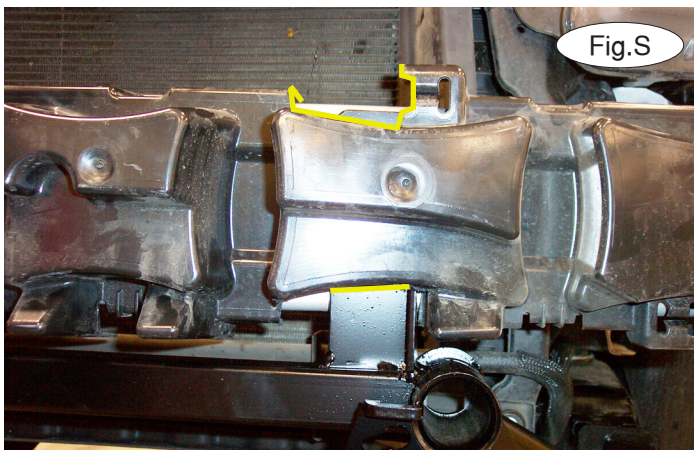

15. Temporarily remove the plastic shock absorption pad by unsnapping four plastic clips attaching it to the back of the fascia. Hold it over the bumper core and mark it, using the yellow lines in Figure S as a guide for trimming.

16. Replace the plastic shock absorption pad. Hold the fascia over the bumper core and mark the grille. **For SHO and Limited models:** use the yellow lines in Figure T as a guide for trimming. **For SL and SE models:** use the yellow lines in Figure U as a guide for trimming.

17. Reassemble the fascia, reversing steps 1 through 4.





BASEPLATE KIT INSTALLATION INSTRUCTIONS

KIT# 524423-1

08/31/10
KS

ROADMASTER, Inc. 6110 NE 127th Ave. Vancouver, WA 98682 360-896-0407 fax 360-735-9300 www.roadmasterinc.com

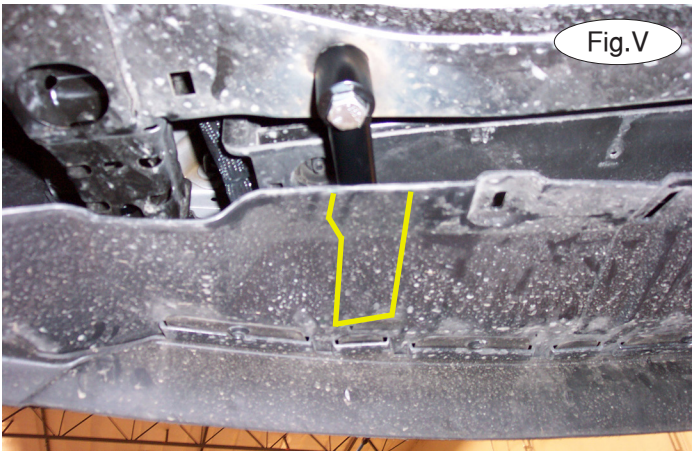

18. Using the yellow lines in Figure V as a guide, trim the lower splash shield to allow clearance for the lower braces.
19. Insert the removable front bracket arms into the front receiver braces, and twist each one 90 degrees to lock.
20. Attach the 8" safety cables with the cable connectors (Q-Links) to the front of the receiver braces (Fig.W).
21. Attach the ends of the safety cables to the tow vehicle's safety cables.
22. Install the tow bar to the mounting bracket according to the manufacturer's instructions.

BOLT TORQUE REQUIREMENTS

Note: The torque values represented below are intended as general guidelines. Torque requirements for specific applications may vary. Roadmaster does not warrant this information to be accurate for all applications and disclaims all liability for any claims or damages which may result from its use.

STANDARD BOLTS

Thread Size	Grade	Torque
5/16.....	5.....	13 ft./lb.
3/8.....	5.....	23 ft./lb.
7/16.....	5.....	37 ft./lb.
1/2.....	5.....	56 ft./lb.
5/8.....	5.....	150 ft./lb.

METRIC BOLTS

Thread Size	Grade	Plated / Unplated
8mm-1.0.....	8.8.....	20 ft./lb. 18 ft./lb.
8mm-1.25.....	8.8.....	19 ft./lb. 18 ft./lb.
10mm-1.25.....	8.8.....	38 ft./lb. 36 ft./lb.
10mm-1.5.....	8.8.....	37 ft./lb. 35 ft./lb.

METRIC BOLTS

Thread Size	Grade	Plated / Unplated
12mm-1.25.....	8.8.....	70 ft./lb. 65 ft./lb.
12mm-1.5.....	8.8.....	66 ft./lb. 61 ft./lb.
12mm-1.75.....	8.8.....	65 ft./lb. 60 ft./lb.
14mm-2.0.....	8.8.....	104 ft./lb. 97 ft./lb.

All illustrations and specifications contained herein are based on the latest information available at the time of publication approval. ROADMASTER, INC. reserves the right to make changes at any time without notice in material, specification and models or to discontinue models.