



BASEPLATE KIT INSTALLATION INSTRUCTIONS

KIT# 524436-4

10/20/16
KS

ROADMASTER, Inc. 6110 NE 127th Ave. Vancouver, WA 98682 360-896-0407 fax 360-735-9300 www.roadmasterinc.com

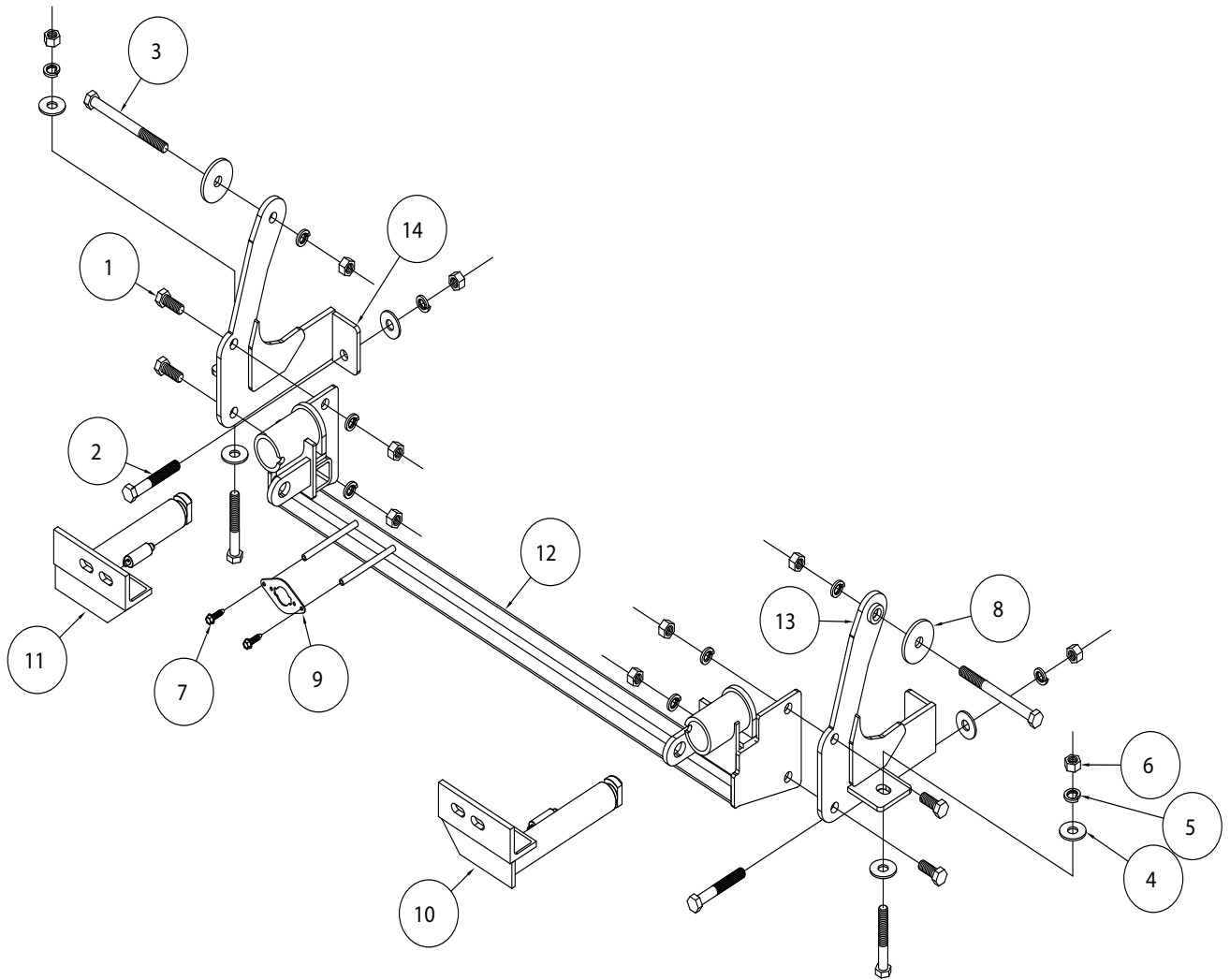

ITEM	QTY	NAME	PART #
1	4	1/2" x 1 1/4" BOLT	350094-00
2	4	1/2" x 3 1/2" BOLT	350103-00
3	2	1/2" x 5 1/2" BOLT	350108-00
4	6	1/2" FLAT WASHER	350308-00
5	10	1/2" LOCK WASHER	350309-00
6	10	1/2" HEX NUT	350258-00
7	2	#10 x 3/4" SELF TAPPING SCREW	350247-35
8	2	1/2" PLATE WASHER	A-003086
9	1	WIRE PLUG PLATE	A-003801
10	1	DRIVER SIDE ARM	C-002597
11	1	PASSENGER SIDE ARM	C-002598
12	1	MAIN RECEIVER	C-002599
13	1	DRIVER SIDE BRACE	C-002600
14	1	PASSENGER SIDE BRACE	C-002601



BASEPLATE KIT INSTALLATION INSTRUCTIONS

KIT# 524436-4

10/20/16
KS

ROADMASTER, Inc. 6110 NE 127th Ave. Vancouver, WA 98682 360-896-0407 fax 360-735-9300 www.roadmasterinc.com

This is one of our EZ4 Twistlock series brackets, which allows the visible front portion of the bracket to be easily removed from the front of the vehicle (Fig.A and Fig.B). The bracket consists of a main receiver brace, two rear support plates, two removable front braces, and a hardware pack.

The main receiver brace mounts to the sub-frame and rear support plates. The removable front braces install in the main receiver brace.

Before starting the installation, lay out the kit components in order, as they will be used. This will give you a visual idea of how the components work, and will also confirm that everything is present and accounted for.



IMPORTANT: All baseplates **must** be assembled with all the bolts left loose for final adjustment and positioning (before tightening) unless otherwise instructed. All bolts **must** be torqued for proper strength. If more than one bolt is used per fastening point, the diagram may only show one. Use flat washers over all slotted holes and lock washers on all fasteners.

WARNING

Failure to heed these warnings or follow the installation instructions may result in a voided warranty, loss of towed vehicle, personal injury or death.

- Do not weld or modify this baseplate or its components. Welding or modification will void the warranty.
- Do not use this document as a basis to design/fabricate a baseplate, as it may not show all parts or structural components.
- We strongly recommend professional installation.
- If the towed vehicle has been in an accident, it must be properly repaired before attaching the baseplate. Do not install the baseplate if any structural frame damage is found.
- The installer must use all bolts and parts supplied. If running changes were made by the vehicle manufacturer after this kit was designed, some bolts or other fasteners may no longer be the correct size. It is the installer's responsibility to verify this kit is securely fastened to the vehicle.
- Use Loctite® Red on all bolts used to secure this baseplate. Torque all bolts to the specifications found at the end of these instructions. Do not over-torque the bolts or failure may occur.
- The installer must inspect the baseplate to ensure adequate clearance, particularly around hoses, air conditioner lines, radiators, etc. or non-warranty failure may result.
- Roadmaster manufactures many styles of baseplates. If your baseplate has removable arms, they must be removed before driving the vehicle, unless the arms can be pinned or padlocked in place. If not secured, the arms could vibrate out.
- Some motorhome chassis have such a tight turning radius that you can damage your motorhome, towed vehicle, tow bar or baseplate while turning sharply. Before getting on the road, test your turning radius in an empty parking lot. Turning too sharply could result in non-warranty damage to your towing system, motorhome and/or towed vehicle.
- Do not back up with the towed vehicle attached or non-warranty damage will occur to your towing system or vehicles.
- The safety cables must connect the towing vehicle to the towed vehicle frame to frame, with the cables crossed, with enough slack for sharp turns. See cable instructions for proper routing. Failure to do so will result in non-warranty damage and/or the loss of the towed vehicle.
- This kit is designed for use with ROADMASTER tow bars and ROADMASTER adapters only. Using this kit with other brands, without an approved ROADMASTER adapter, may result in non-warranty damage or injury.
- Receiver extensions and out-of-level towing situations of 3 inches or more. This can cause the system to swing much higher and lower, causing excessive strain on the tow bar, baseplate and frame. That can cause the towing system to fail, causing property damage, personal injury or even death. If you must use a receiver extension or drop hitch to tow, it will reduce your receiver's weight capacity by 1/3 to avoid damaging your system. Never use more than one extension and/or drop hitch, as this will void your warranty.
- Every 3,000 miles, the owner must inspect all mounting points for cracks or fatigue, and check the fasteners for proper torque, according to the bolt torque requirements chart on the last page of these instructions.
- The owner must follow the vehicle manufacturer's instructions to prepare the vehicle for towing. Failure to do so may cause severe damage to the vehicle.
- This baseplate is only warranted for the original installation. Installing a used baseplate on another vehicle is not recommended and will void the warranty.



BASEPLATE KIT INSTALLATION INSTRUCTIONS

KIT# 524436-4

10/20/16
KS

ROADMASTER, Inc. 6110 NE 127th Ave. Vancouver, WA 98682 360-896-0407 fax 360-735-9300 www.roadmasterinc.com

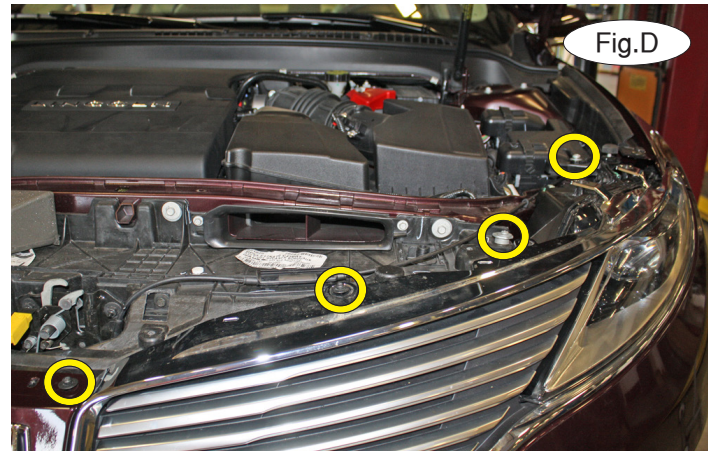
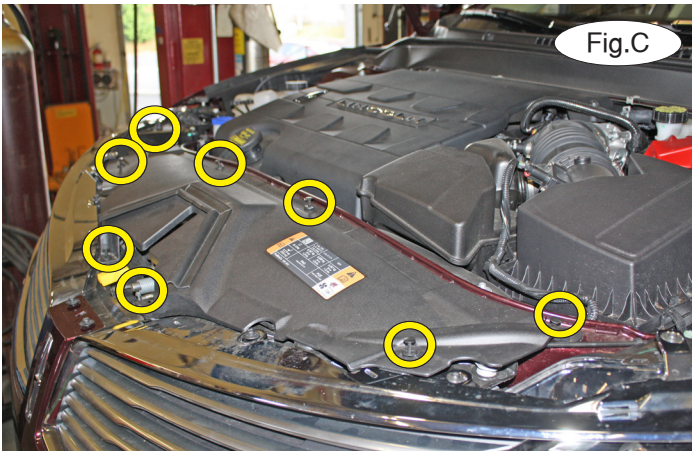

1. **Important:** please use all supplied bolts and parts and read all instructions carefully before beginning this installation. The majority of questions you may have can be answered within the text, and proper installation will ensure safe and secure travel. Now, begin the installation. Remove eight plastic fasteners attaching the radiator cover to the core support (Fig.C).

2. On each side, remove three T25 Torx (head) screws attaching the fascia and headlights to the core support and one T30 Torx (head) bolt attaching the headlights to the core support (Fig.D).

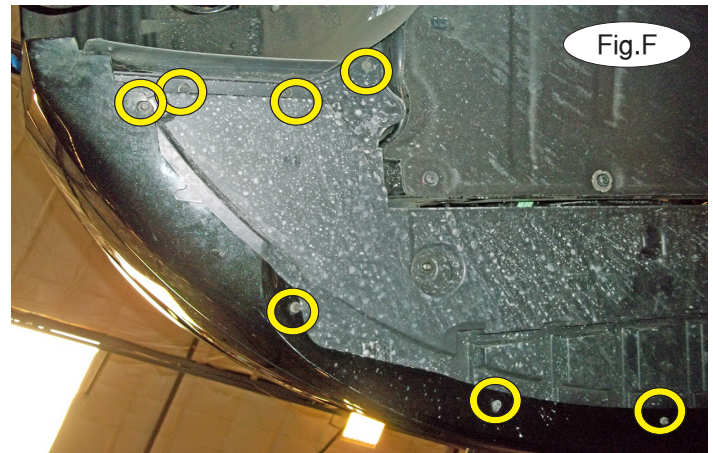

3. On each side, remove four 7mm (head) screws attaching the fender liner to the fascia (Fig.E).

4. On each side, remove seven 7mm (head) screws attaching the splash shield to the bottom of the fascia and the fender liner (Fig.F – driver's side).

5. Remove 11 T30 Torx screws and two plastic fasteners attaching the splash shield to the subframe (Fig.G).

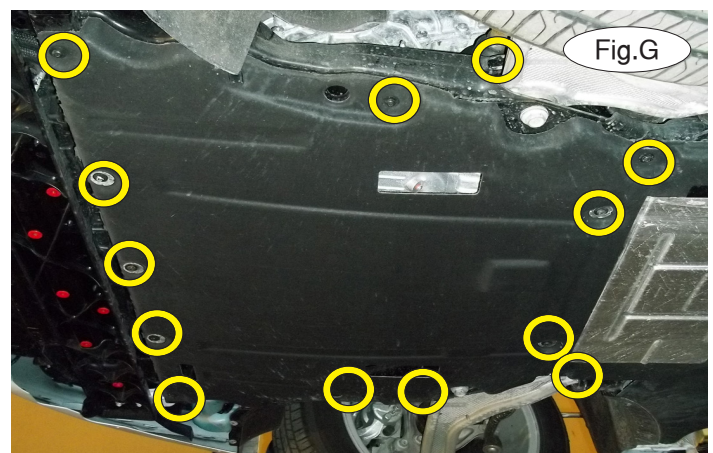



BASEPLATE KIT INSTALLATION INSTRUCTIONS

KIT# 524436-4

10/20/16
KS

ROADMASTER, Inc. 6110 NE 127th Ave. Vancouver, WA 98682 360-896-0407 fax 360-735-9300 www.roadmasterinc.com

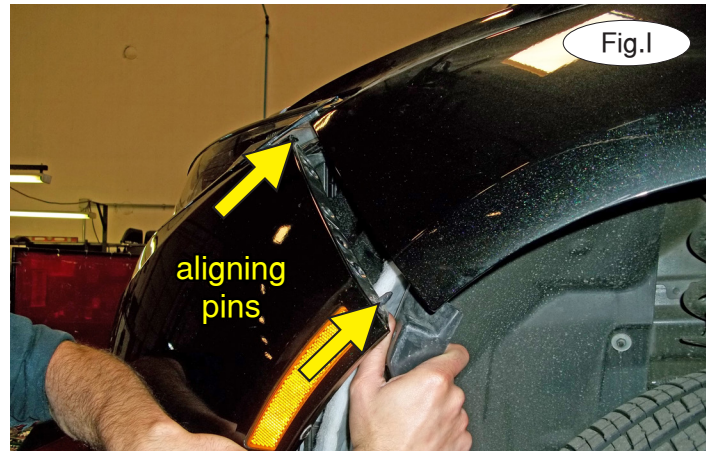

6. On each side, pull the fender liner completely out to gain access to the bolts located behind the fascia. Use an 8mm socket with an extension to remove two bolts. Their approximate location is denoted by the yellow arrows in Figure H.

7. On each side, pull the fender liner completely away from the fascia and pull down on the fascia to slide out the two aligning pins from the fender (Fig.I). Figure J shows the headlight pin that also needs to be released.

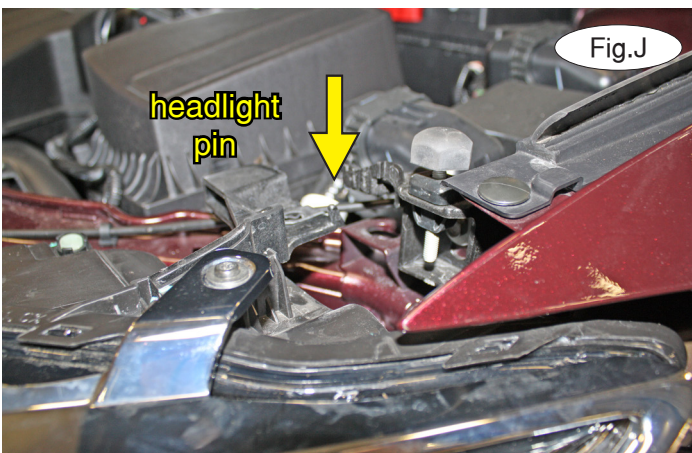

8. Ensure that when you remove the fascia that the headlights are still attached to the fascia (Fig.K and Fig.L). Now, disconnect all electrical connectors attaching the fascia wiring harness to the vehicle. *Note:* you may need a second person to assist in removing the fascia and disconnecting the fascia and headlight electrical connectors.





BASEPLATE KIT INSTALLATION INSTRUCTIONS

KIT# 524436-4

10/20/16
KS

ROADMASTER, Inc. 6110 NE 127th Ave. Vancouver, WA 98682 360-896-0407 fax 360-735-9300 www.roadmasterinc.com

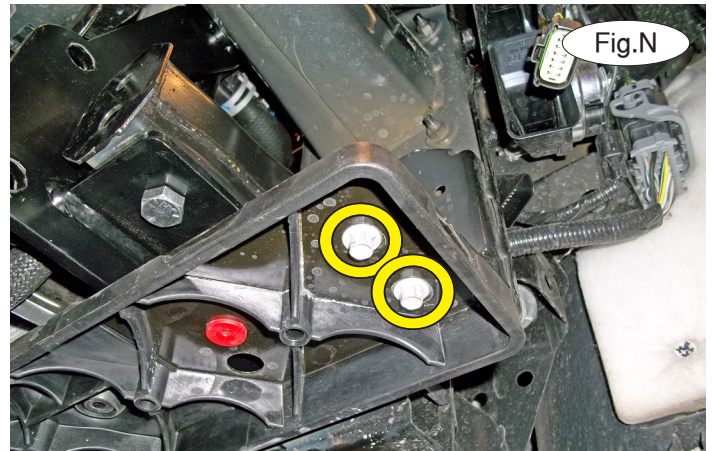
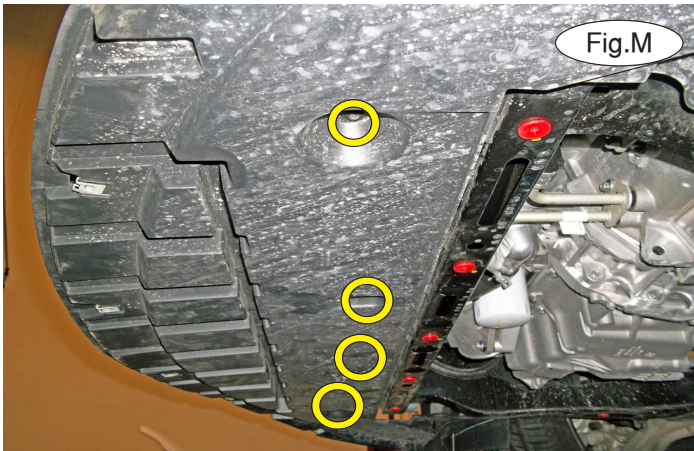

9. Remove four T30 Torx screws attaching the splash shield to the radiator support (Fig.M).
10. On each side, remove two 10mm (head) bolts attaching the radiator support to the frame (Fig.N) and carefully ease the radiator down and let it hang for now.

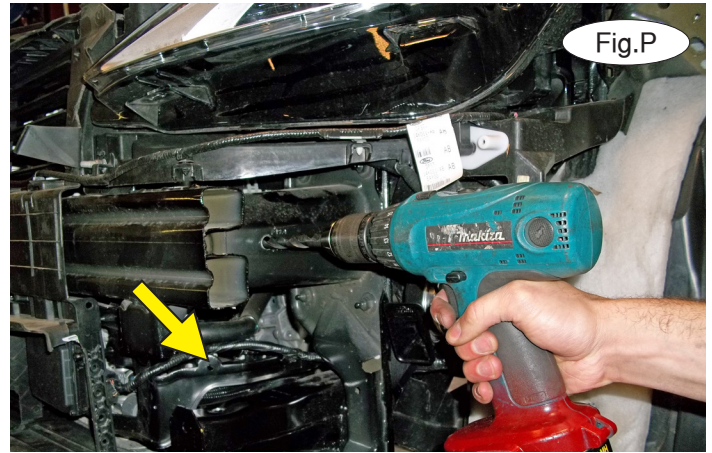
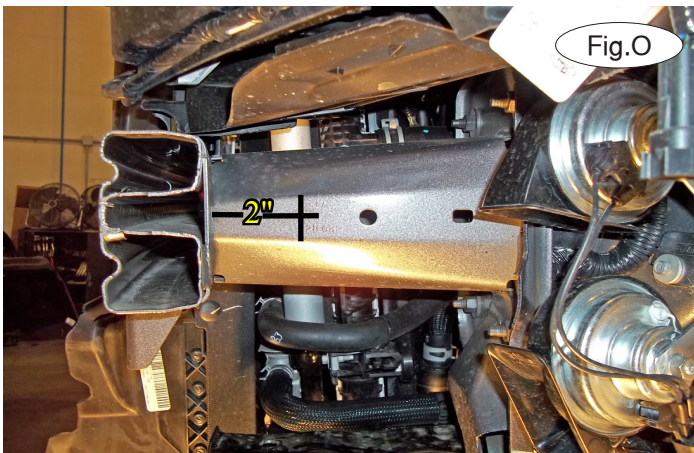

11. On each side, mark a point for drilling that is centered on the side of the bumper core from top to bottom and 2" from the back of the bumper core (Fig.O).
12. On the driver's side only, disconnect the wiring loom running along the outside of the sensor bracket and reattach it on the inside of the bracket (Fig.P – yellow arrow).

Now, use a 1/2" drill to drill through the outside of the bumper core at the point you marked in step 11 and through the pre-existing hole on the inside of the bumper core (Fig.P). If you experience difficulty in drilling due to the hard composition of the bumper core, drill a pilot hole first. Make certain you use a sharp drill bit. *Note:* use a piece of metal as a buffer between the drill bit and the engine components.

13. On each side, carefully push the radiator out of the way and use a 1/2" drill to enlarge the pre-existing holes in the bottom and top of the sub frame (Fig.Q).





BASEPLATE KIT INSTALLATION INSTRUCTIONS

KIT# 524436-4

10/20/16
KS

ROADMASTER, Inc. 6110 NE 127th Ave. Vancouver, WA 98682 360-896-0407 fax 360-735-9300 www.roadmasterinc.com

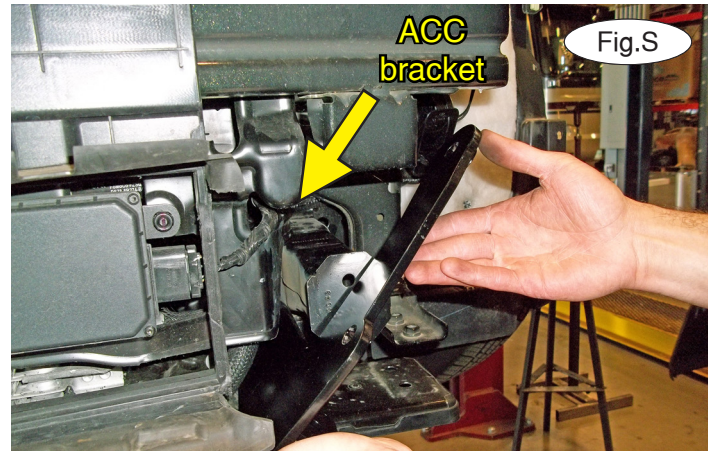
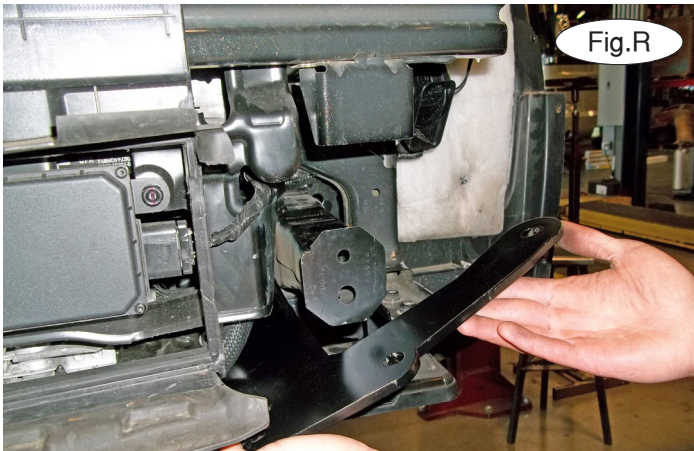

14. Working on the driver's side only, lay the rear support plate on its side and under the subframe (Fig.R) and rotate it under the bumper core (Fig.S), aligning the upper hole in the plate with the hole drilled in step 12 (Fig.T). **Note: inspect the clearance between the rear support plate and the ACC bracket. Due to manufacturing variances, they may be contacting. If that is the case, use a die grinder on the ACC bracket until they are no longer touching.**

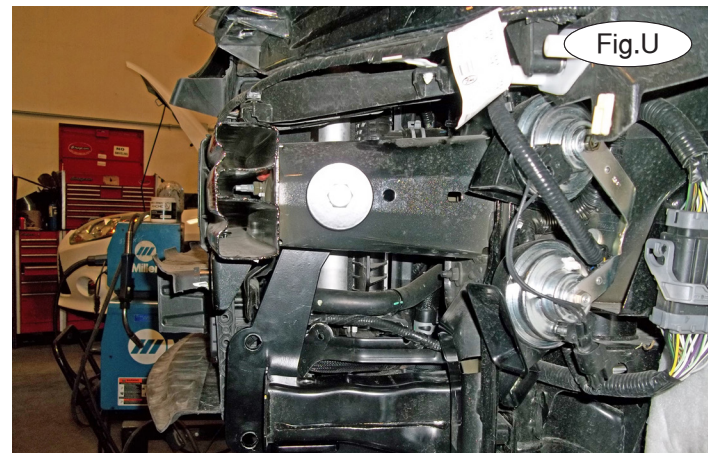
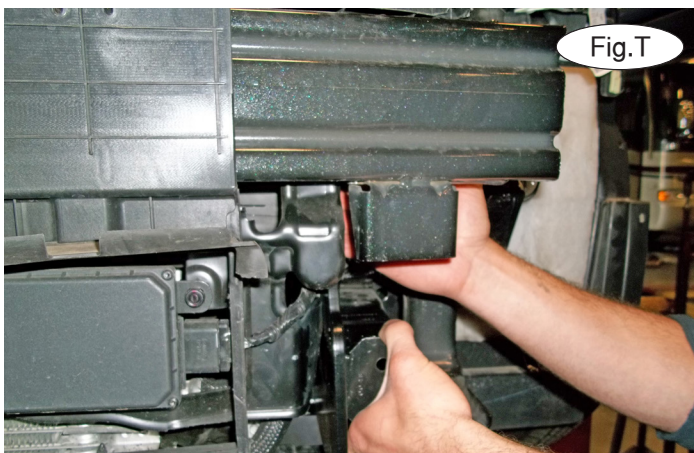

15. Now, place one of the supplied $\frac{1}{2}$ " plate washers over a $\frac{1}{2}$ " x $5\frac{1}{2}$ " bolt and bolt through the bumper core and rear support bracket and finish with a $\frac{1}{2}$ " lock washer and nut (Fig.U). **Note:** ensure proper alignment, as the bolts will receive Loctite® Red and will be torqued at the end of these instructions.

16. Repeat steps 14 and 15 for the passenger side but tilt the rear support plate slightly to the right to clear the bumper core first (Fig.V).





BASEPLATE KIT INSTALLATION INSTRUCTIONS

KIT# 524436-4

10/20/16
KS

ROADMASTER, Inc. 6110 NE 127th Ave. Vancouver, WA 98682 360-896-0407 fax 360-735-9300 www.roadmasterinc.com

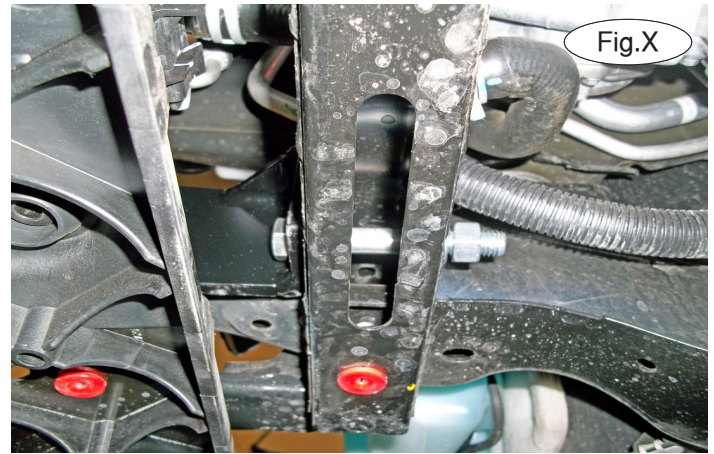
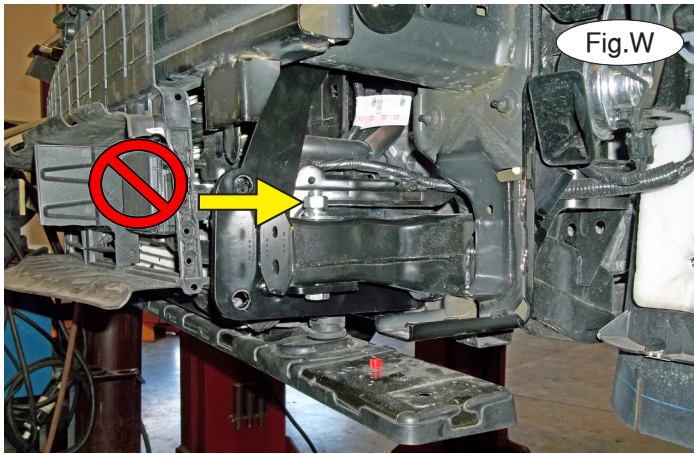

17. On each side, using one of the supplied $\frac{1}{2}$ " x $3\frac{1}{2}$ " bolts, bolt up through the rear support plate and subframe and finish with a $\frac{1}{2}$ " lock washer and nut (Fig.W). **Caution! Under no circumstances should you attempt to move, adjust or disconnect the ACC unit (indicated in red in Figure W). Doing so may cause cruise control malfunction and/or computer error codes that may require the dealership to repair or reset. Note: ensure that the bracket is not contacting the ACC bracket in any way before proceeding to the next step.**

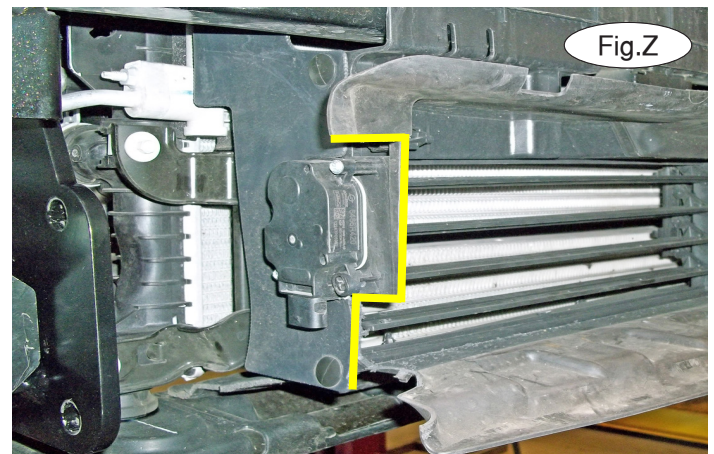
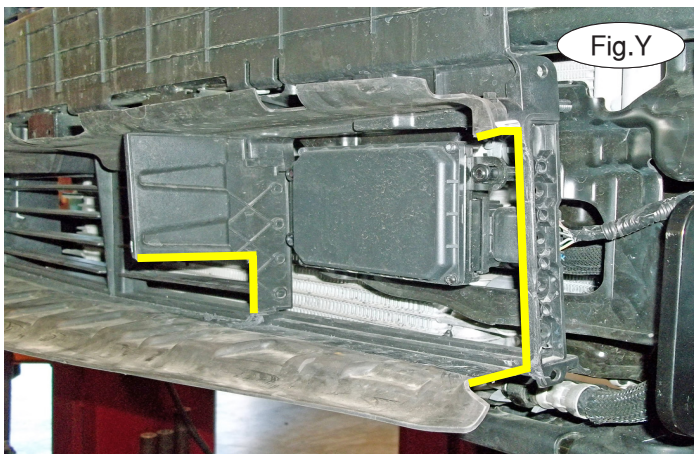

18. On each side, using one of the supplied $\frac{1}{2}$ " x $3\frac{1}{2}$ " bolts, bolt through the rear support plate and back of the subframe, and finish with a $\frac{1}{2}$ " flat washer, lock washer and nut (Fig.X).

19. Trim the louver shroud as indicated by the yellow lines on the driver's side (Fig.Y) and the passenger side (Fig.Z).

20. Position the main receiver brace between the two rear support plates, aligning the mounting holes, and bolt it into place on each side using two $\frac{1}{2}$ " x $1\frac{1}{4}$ " bolts, two $\frac{1}{2}$ " lock washers and two nuts (Fig.AA).

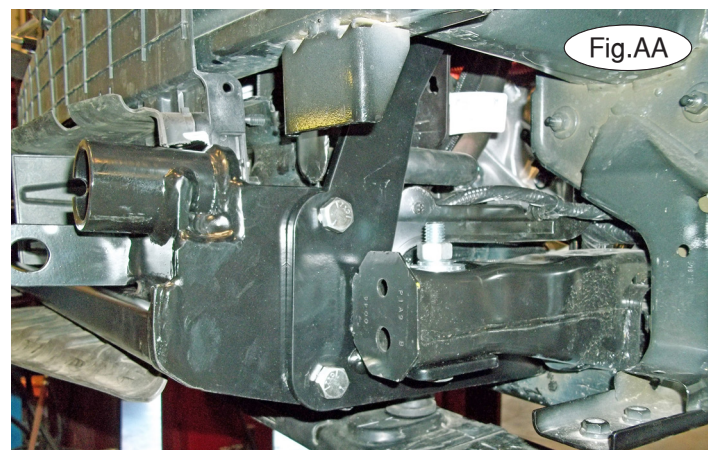



BASEPLATE KIT INSTALLATION INSTRUCTIONS

KIT# 524436-4

10/20/16
KS

ROADMASTER, Inc. 6110 NE 127th Ave. Vancouver, WA 98682 360-896-0407 fax 360-735-9300 www.roadmasterinc.com

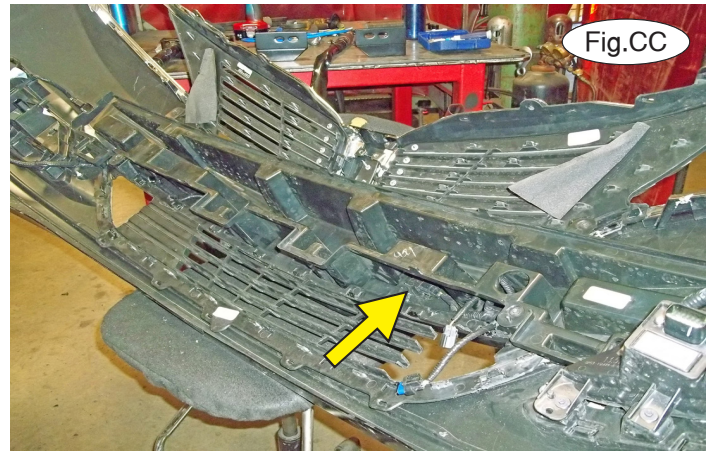
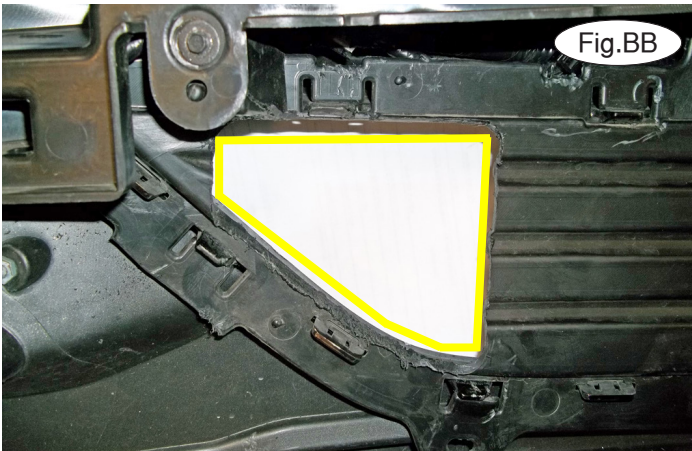

21. Pull up on the bracket and then tighten the bolts installed in step 20. Then, tighten all bolts to the bolt torque requirements found at the end of these instructions. *Note:* use Loctite® Red on all nuts and bolts.
22. Trim the fascia using the yellow lines as a guide to allow clearance for the main receiver brace (Fig.BB).
23. Remove the lower two 7mm (head) screws attaching the shock absorption pad to the back of the fascia. Now, disconnect the middle section of the fascia wiring harness and tuck it under the shock absorption pad, making certain the wiring harness is sitting comfortably behind the shock absorption pad and that all connectors are hanging out enough to be easily reconnected. The yellow arrow indicates where the harness should be tucked from right to left across the back of the fascia (Fig.CC).



24. Now, trim the bottom of the shock absorption pad to allow clearance for the main receiver brace, using the yellow lines as a reference for trimming (Fig.DD).
25. Use steps 1 through 10 as a reference for reinstalling the fascia but forego steps 4 and 9 for the splash shielding re-installation until after you have re-attached all harness connectors, and then install the front splash shielding. *Note:* make certain that the metal pin on the back of the headlight aligns with the plastic bracket in order to reinstall the fascia properly on each side (Fig.EE).



BASEPLATE KIT INSTALLATION INSTRUCTIONS

KIT# 524436-4

10/20/16
KS

ROADMASTER, Inc. 6110 NE 127th Ave. Vancouver, WA 98682 360-896-0407 fax 360-735-9300 www.roadmasterinc.com

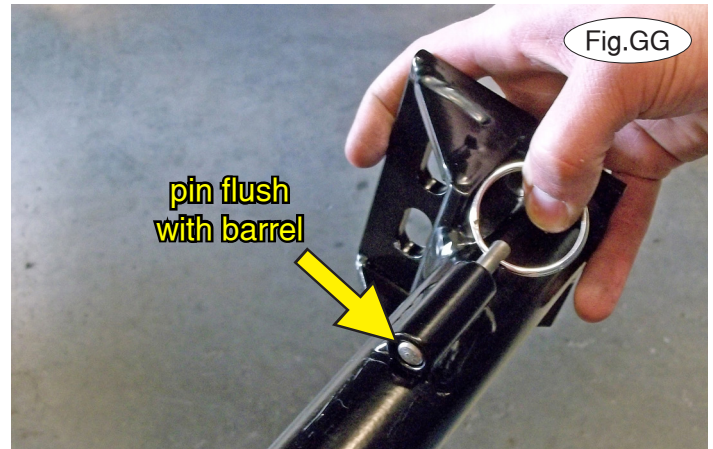
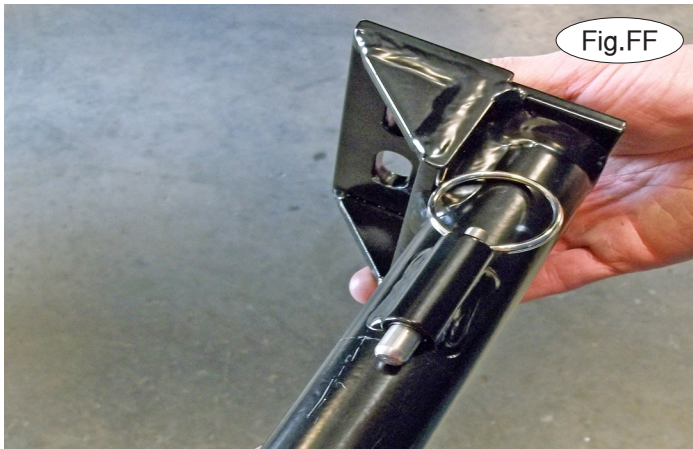

26. **Note: the following four images are for illustration purposes only, as your specific application may be slightly different.**

The spring-loaded pin on the removable arm snaps into a notch on the receiver, locking the removable arm into its final towing position. Before inserting each arm into the receiver, verify that the spring is working by ensuring that the spring-loaded pin moves easily back and forth within the barrel when pulled and that it can be pulled flush with the face of the barrel (Fig.FF and Fig.GG).

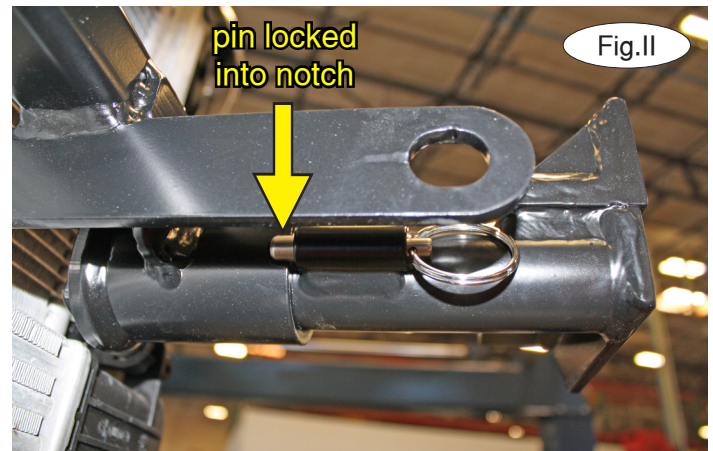
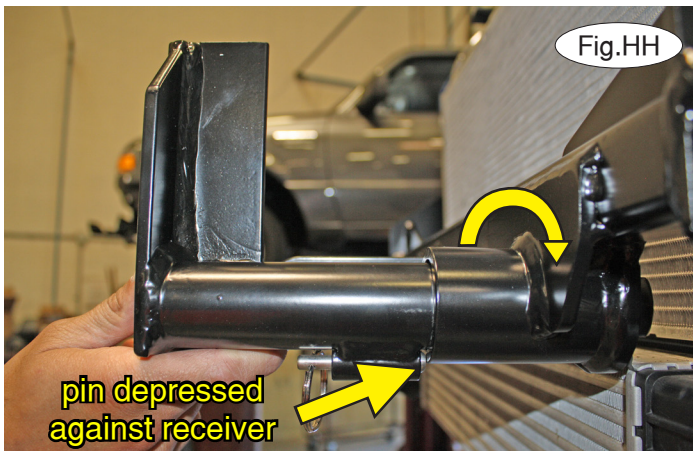

27. On each side, insert the removable front bracket arm into the front receiver 90 degrees from its final towing position, depressing the spring-loaded pin against the receiver (Fig.HH). Now, twist back 90 degrees until the spring-loaded pin snaps into place in the notch on the receiver, locking the arm into place in its final towing position (Fig.II).

Please note: it is the owner's responsibility to ensure the locking of the pins before towing. Otherwise, failure of the towing system will result.

28. Install the tow bar to the mounting bracket according to the manufacturer's instructions.



BASEPLATE KIT INSTALLATION INSTRUCTIONS

KIT# 524436-4

10/20/16
KS

ROADMASTER, Inc. 6110 NE 127th Ave. Vancouver, WA 98682 360-896-0407 fax 360-735-9300 www.roadmasterinc.com

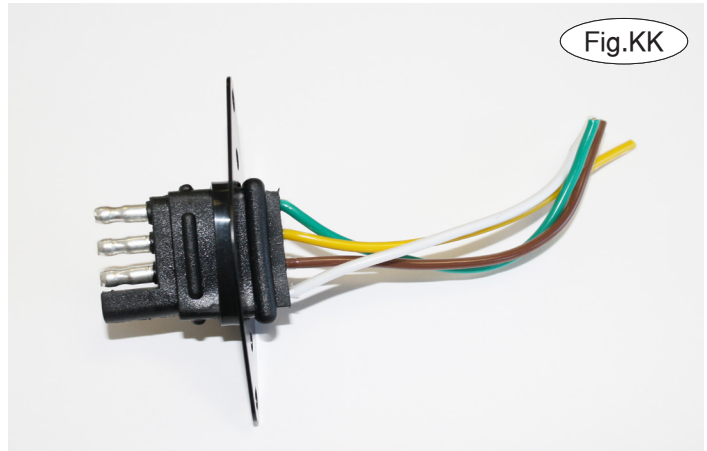
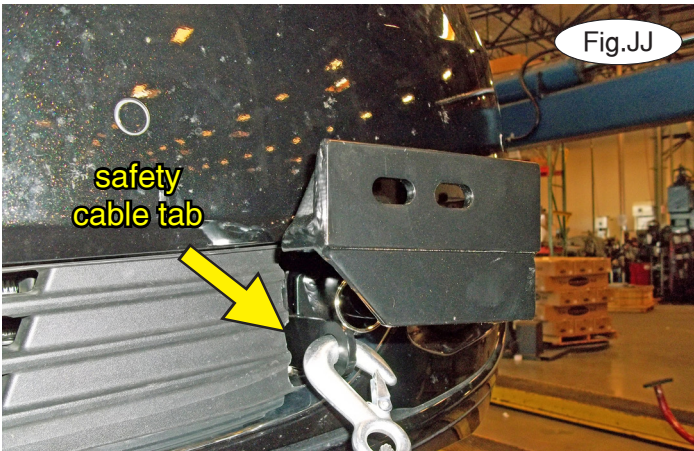

IMPORTANT!

Safety cables are required by law. When towing, connect safety cables to the safety cable tabs shown in Figure JJ. Make certain there is adequate slack in the cables to allow a full turning radius; otherwise, damage will result. If necessary, longer cables or cable extensions are available.

Three options for attaching the wiring plug to the main receiver brace

For six-wire plugs: use the two supplied 3/4" self-tapping screws to attach the electrical plug directly to the rods on the front of the main receiver brace.

For four-wire round plugs: attach to the plug mounting plate and then use the two supplied 3/4" self-tapping screws to attach the mounting plate to the rods on the front of the main receiver brace.

For four-wire flat plugs: place the plug through the mounting plug plate, and then secure it using the supplied zip tie on the front of the plug (Fig.KK). Use the two supplied 3/4" self-tapping screws to attach the mounting plate to the rods on the front of the main receiver brace.

BOLT TORQUE REQUIREMENTS

Note: The torque values represented below are intended as general guidelines. Torque requirements for specific applications may vary. Roadmaster does not warrant this information to be accurate for all applications and disclaims all liability for any claims or damages which may result from its use.

STANDARD BOLTS

Thread Size	Grade	Torque
3/8.....	5.....	13 ft./lb.
3/8.....	5.....	23 ft./lb.
7/16.....	5.....	37 ft./lb.
1/2.....	5.....	56 ft./lb.
5/8.....	5.....	150 ft./lb.

METRIC BOLTS

Thread Size	Grade	Plated / Unplated
8mm-1.0	8.8	20 ft./lb. 18 ft./lb.
8mm-1.25	8.8	19 ft./lb. 18 ft./lb.
10mm-1.25	8.8	38 ft./lb. 36 ft./lb.
10mm-1.5	8.8	37 ft./lb. 35 ft./lb.

METRIC BOLTS

Thread Size	Grade	Plated / Unplated
12mm-1.25	8.8	70 ft./lb. 65 ft./lb.
12mm-1.5	8.8	66 ft./lb. 61 ft./lb.
12mm-1.75	8.8	65 ft./lb. 60 ft./lb.
14mm-2.0	8.8	104 ft./lb. 97 ft./lb.

All illustrations and specifications contained herein are based on the latest information available at the time of publication approval. ROADMASTER, INC. reserves the right to make changes at any time without notice in material, specification and models or to discontinue models.