



# BASEPLATE KIT INSTALLATION INSTRUCTIONS

**KIT# 524444-4**

08/18/22  
KS

ROADMASTER, Inc. 6110 NE 127th Ave. Vancouver, WA 98682 360-896-0407 fax 360-735-9300 www.roadmasterinc.com

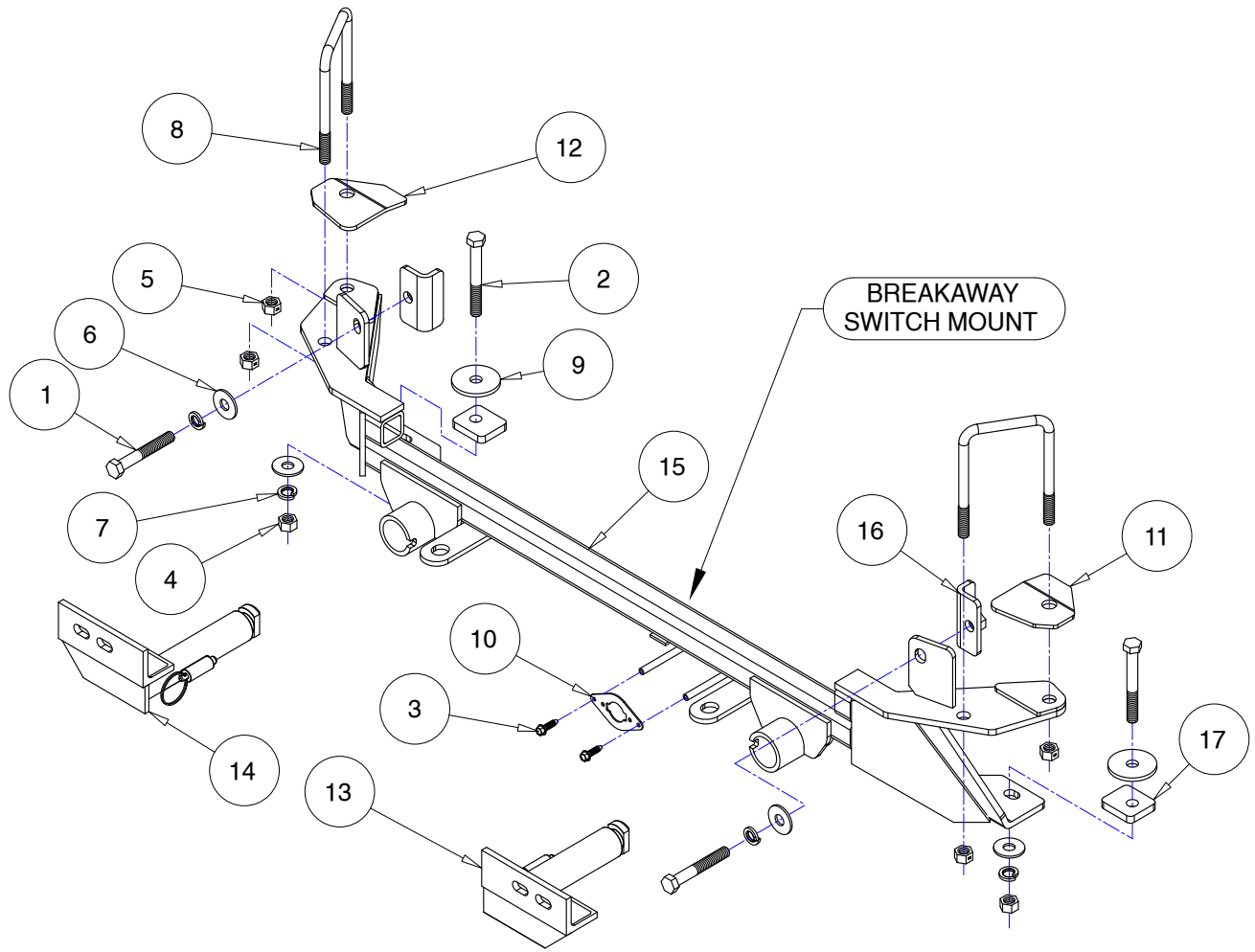

ITEM	QTY	NAME	MATERIAL
1	2	1/2" x 3 1/2" BOLT	350103-00
2	2	1/2" x 4" BOLT	350105-00
3	2	#10 x 3/4" SELF DRILLING SCREW	350247-35
4	2	1/2" HEX NUT	350258-00
5	4	1/2" TWO WAY LOCKNUT	350258-20
6	4	1/2" SAE WASHER	350308-20
7	4	1/2" LOCK WASHER	350309-00
8	2	1/2" x 3.5" x 5.5 U-BOLT	357021-50
9	2	1/2" PLATE WASHER	A003086
10	1	WIRE PLUG PLATE	A003801
11	1	DRIVER SIDE SHIM PLATE	B002900
12	1	PASSENGER SIDE SHIM PLATE	B002901
13	1	DRIVER SIDE ARM	C002813
14	1	PASSENGER SIDE ARM	C002814
15	1	MAIN RECEIVER	C002924
16	2	THREADED BACKING PLATE	C003517
17	2	SPACER	A000765
18	1	ZIP TIE	300140-8



# BASEPLATE KIT INSTALLATION INSTRUCTIONS

**KIT# 524444-4**

08/18/22  
KS

ROADMASTER, Inc. 6110 NE 127th Ave. Vancouver, WA 98682 360-896-0407 fax 360-735-9300 www.roadmasterinc.com

This is one of our crossbar-style series baseplates, which allows the visible front portion of the kit to be easily removed from the front of the vehicle (Fig.A and Fig.B). The kit consists of a main receiver brace, two removable front braces, and a hardware pack.

The main receiver brace mounts to the bumper core and subframe. The removable front braces install in the main receiver brace.

Before starting the installation, lay out the kit components in order, as they will be used. This will give you a visual idea of how the components work, and will also confirm that everything is present and accounted for.



**IMPORTANT:** All baseplates *must* be assembled with all the bolts left loose for final adjustment and positioning (before tightening) unless otherwise instructed. All bolts *must* be torqued for proper strength. If more than one bolt is used per fastening point, the diagram may only show one. Use flat washers over all slotted holes and lock washers on all fasteners.

## **WARNING**

Failure to heed these warnings or follow the installation instructions may result in a voided warranty, loss of towed vehicle, personal injury or death.

- Do not weld or modify this baseplate or its components. Welding or modification will void the warranty.
- Do not use this document as a basis to design/fabricate a baseplate, as it may not show all parts or structural components.
- We strongly recommend professional installation.
- If the towed vehicle has been in an accident, it must be properly repaired before attaching the baseplate. Do not install the baseplate if any structural frame damage is found.
- The installer must use all bolts and parts supplied. If running changes were made by the vehicle manufacturer after this kit was designed, some bolts or other fasteners may no longer be the correct size. It is the installer's responsibility to verify this kit is securely fastened to the vehicle.
- Use Loctite® Red on all bolts used to secure this baseplate. Torque all bolts to the specifications found at the end of these instructions. Do not over-torque the bolts or failure may occur.
- The installer must inspect the baseplate to ensure adequate clearance, particularly around hoses, air conditioner lines, radiators, etc. or non-warranty failure may result.
- Roadmaster manufactures many styles of baseplates. If your baseplate has removable arms, they must be removed before driving the vehicle, unless the arms can be pinned or padlocked in place. If not secured, the arms could vibrate out.
- Some motorhome chassis have such a tight turning radius that you can damage your motorhome, towed vehicle, tow bar or baseplate while turning sharply. Before getting on the road, test your turning radius in an empty parking lot. Turning too sharply could result in non-warranty damage to your towing system, motorhome and/or towed vehicle.
- Do not back up with the towed vehicle attached or non-warranty damage will occur to your towing system or vehicles.
- The safety cables must connect the towing vehicle to the towed vehicle frame to frame, with the cables crossed, with enough slack for sharp turns. See cable instructions for proper routing. Failure to do so will result in non-warranty damage and/or the loss of the towed vehicle.
- This kit is designed for use with ROADMASTER tow bars and ROADMASTER adapters only. Using this kit with other brands, without an approved ROADMASTER adapter, may result in non-warranty damage or injury.
- Receiver extensions and out-of-level towing situations of 3 inches or more. This can cause the system to swing much higher and lower, causing excessive strain on the tow bar, baseplate and frame. That can cause the towing system to fail, causing property damage, personal injury or even death. If you must use a receiver extension or drop hitch to tow, it will reduce your receiver's weight capacity by 1/3 to avoid damaging your system. Never use more than one extension and/or drop hitch, as this will void your warranty.
- Every 3,000 miles, the owner must inspect all mounting points for cracks or fatigue, and check the fasteners for proper torque, according to the bolt torque requirements chart on the last page of these instructions.
- The owner must follow the vehicle manufacturer's instructions to prepare the vehicle for towing. Failure to do so may cause severe damage to the vehicle.
- This baseplate is only warranted for the original installation. Installing a used baseplate on another vehicle is not recommended and will void the warranty.



# BASEPLATE KIT INSTALLATION INSTRUCTIONS

**KIT# 524444-4**

08/18/22  
KS

ROADMASTER, Inc. 6110 NE 127th Ave. Vancouver, WA 98682 360-896-0407 fax 360-735-9300 www.roadmasterinc.com

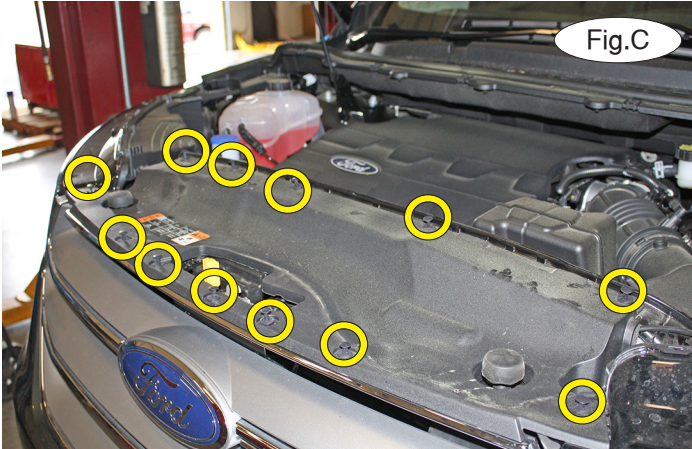

1. **Important:** please use all supplied bolts and parts and read all instructions carefully before beginning this installation. The majority of questions you may have can be answered within the text, and proper installation will ensure safe and secure travel. Now, begin the installation by removing 12 plastic fasteners attaching the radiator cover to the core support (Fig.C).

2. Remove six 10mm (head) bolts attaching the fascia to the core support (Fig.D).



3. On each side, remove six 5.5mm screws attaching the fender liner to the fascia (Fig.E).

4. On each side, pull back the fender liner and remove three 8mm (head) bolts attaching the fascia to the frame (Fig.F).

5. On each side, remove the splash shielding by removing seven 5.5mm screws (Fig.G) and two T30 Torx bolts and one plastic fastener (Fig.H).

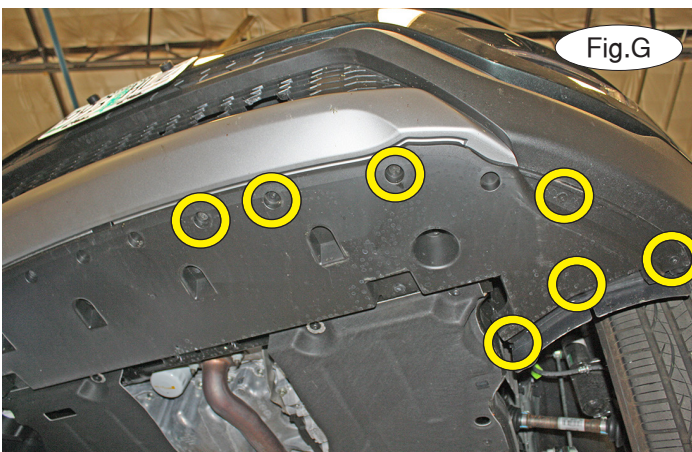



# BASEPLATE KIT INSTALLATION INSTRUCTIONS

**KIT# 524444-4**

08/18/22  
KS

ROADMASTER, Inc. 6110 NE 127th Ave. Vancouver, WA 98682 360-896-0407 fax 360-735-9300 www.roadmasterinc.com

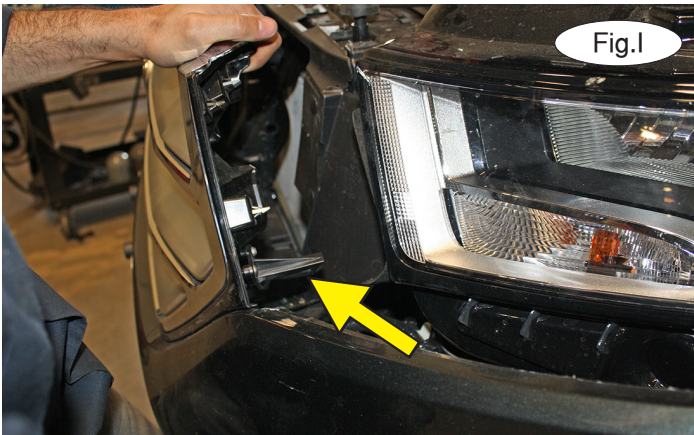

6. On each side, pull forward and down on the top of the fascia to release the plastic clip indicated in Figure I. On the driver's side only, disconnect all electrical connectors (Fig.J) and then set the fascia aside. *Note:* it is possible to disconnect the electrical connectors from underneath before removing the fascia. **For models equipped with a front camera sprayer:** disconnect the sprayer hose from the sprayer fitting and then release all of the clips attaching the sprayer hose to the fascia (Fig.K – only three clips indicated). Secure the hose above the reservoir for now. *Note:* it may be necessary to use either a second person to hold the fascia during this process or prop the fascia after removal.

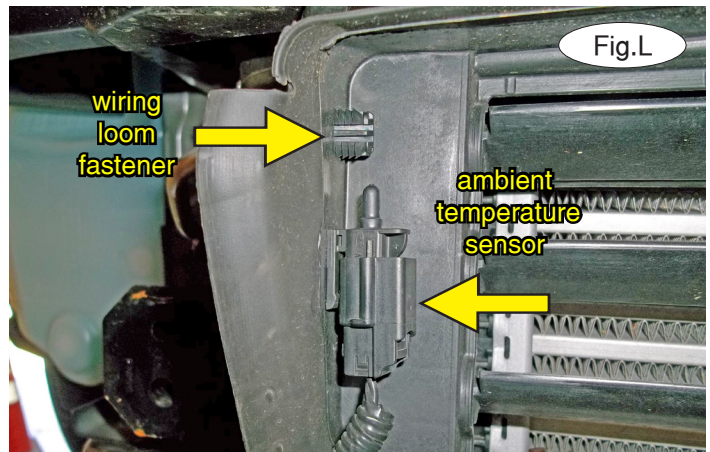
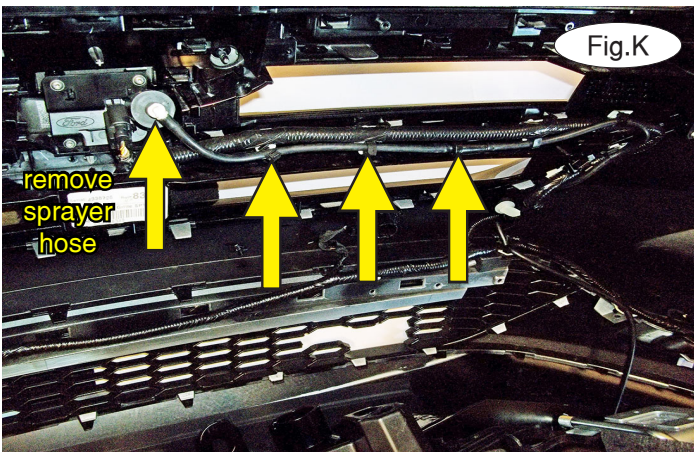

7. On the passenger side, disconnect the ambient temperature sensor and the plastic fastener (Fig.L) attaching its wiring loom and let it hang down for now.

8. On each side, trim the air dam as shown (Fig.M – driver's side, Fig.N – passenger side). **For models with louvers:** you will also need to trim out an additional piece of the louver housing using the same profile (Fig.O – next page).

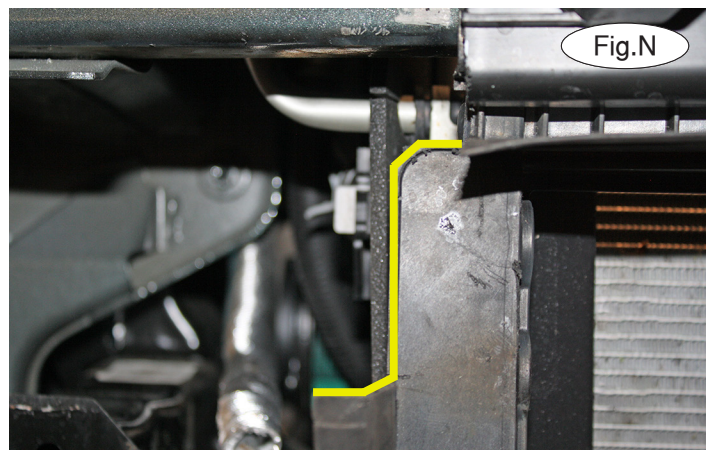
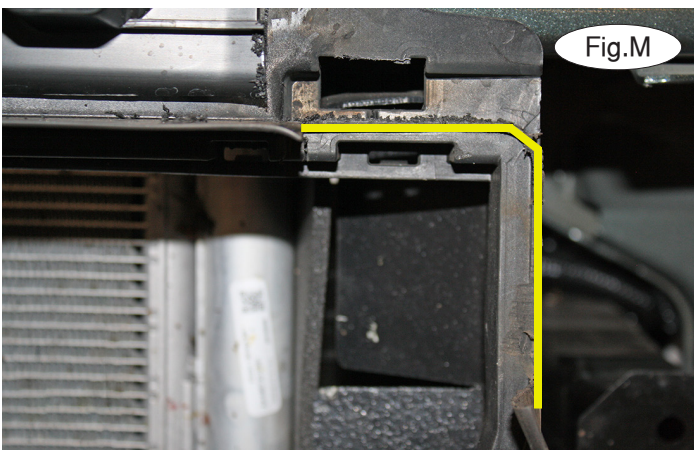



# BASEPLATE KIT INSTALLATION INSTRUCTIONS

**KIT# 524444-4**

08/18/22  
KS

ROADMASTER, Inc. 6110 NE 127th Ave. Vancouver, WA 98682 360-896-0407 fax 360-735-9300 www.roadmasterinc.com

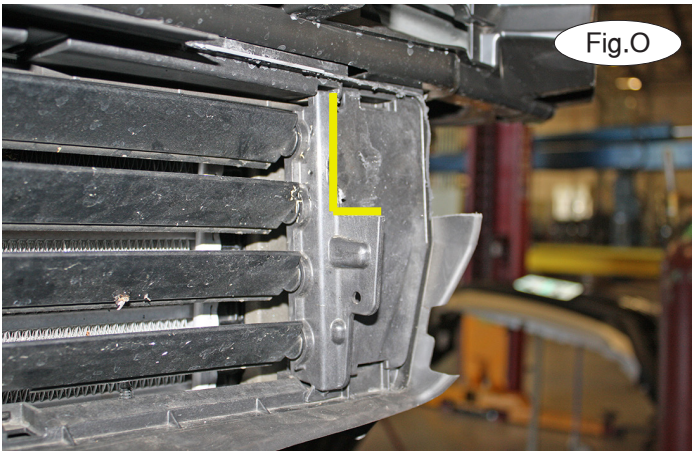

Fig.O

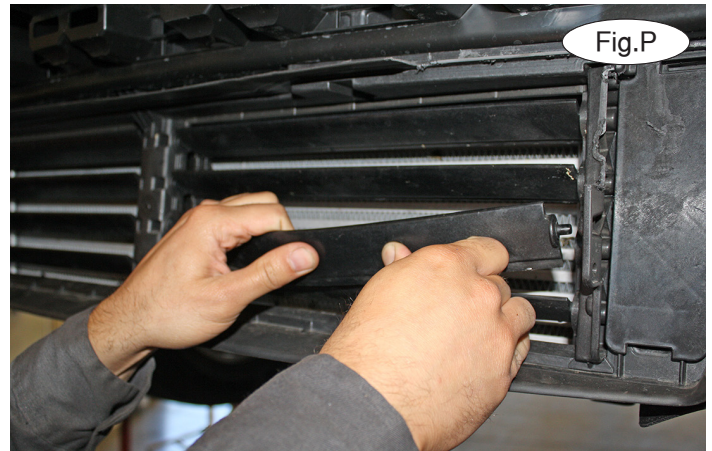

Fig.P

9. **For models without louvers:** Proceed to step 11. **For models with louvers:** On each side, slightly bend the second louver from the bottom to pull out its hinge pins (Fig.P). The louvers will not be replaced. *Note:* retain the louvers for replacement in case the bracket is ever removed.

10. On each side, on the top of the bottom louver, trim out a 2" x 3/8" section as indicated in red in Figure Q, where the cut starts at 5/8" and ends 2-5/8" from the outside edge, and 3/8" down.

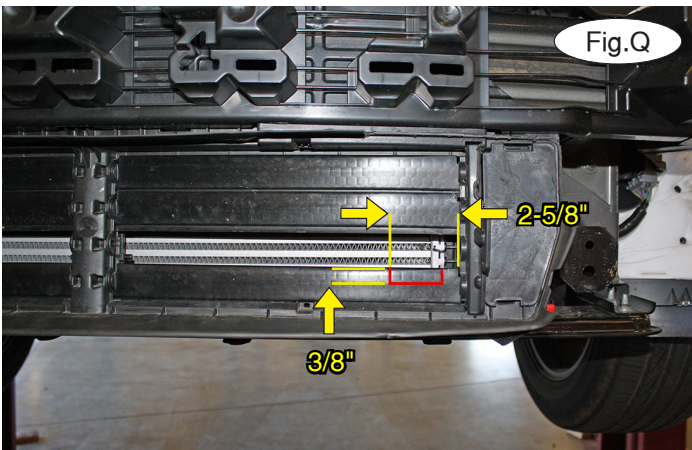

Fig.Q

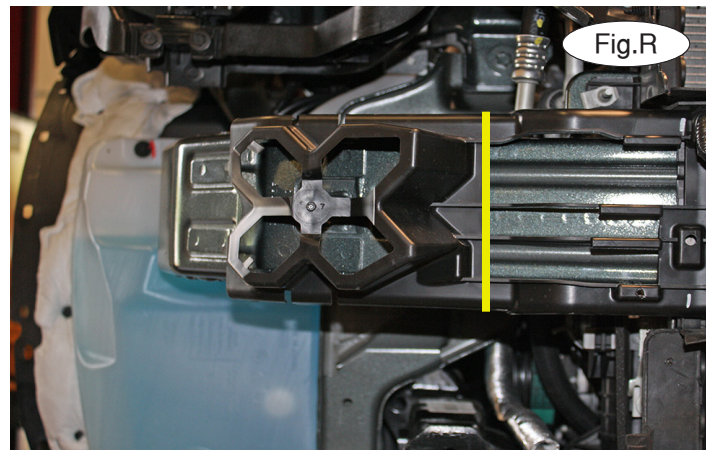

Fig.R

11. Trim off the ends of the shock absorption pad as shown to allow clearance for the main receiver brace (Fig.R – passenger side) and (Fig.S – driver's side).

12. On each side, place the supplied shim plate on top of the bumper core so that the bend is facing down and so it fits into the bumper profile and place the U bolt over the bumper core and through the shim plate (Fig.T).

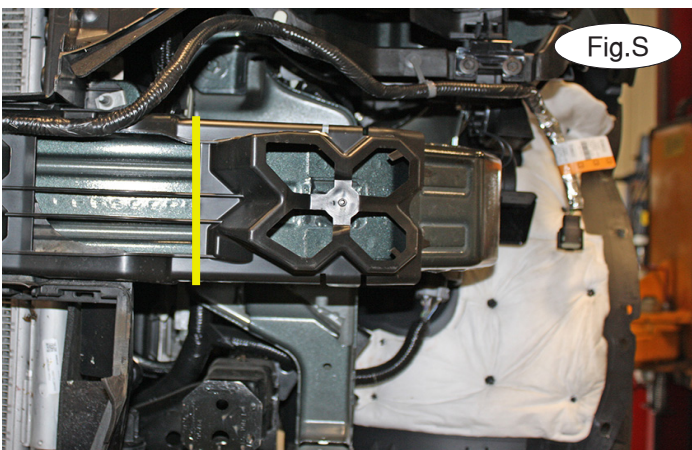

Fig.S



Fig.T



# BASEPLATE KIT INSTALLATION INSTRUCTIONS

**KIT# 524444-4**

08/18/22  
KS

ROADMASTER, Inc. 6110 NE 127th Ave. Vancouver, WA 98682 360-896-0407 fax 360-735-9300 www.roadmasterinc.com

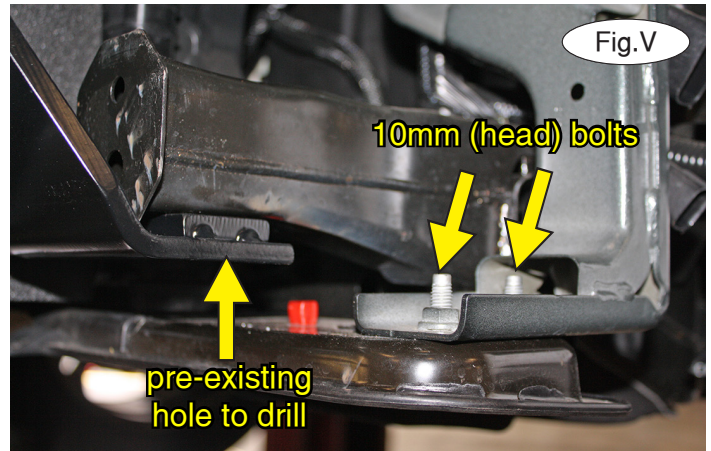
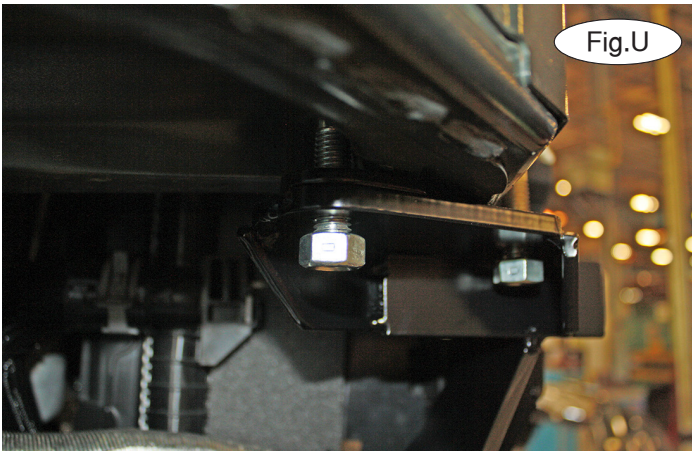

13. On each side, place the main receiver brace under the bumper core and over the U bolts and then thread on the  $\frac{1}{2}$ " two-way locknuts (Fig.U). *Note:* the two-way locknuts have a dimple on the side and are self-locking. *Note:* ensure that wiring looms are not being pinched between the bracket and frame.

14. On each side, remove two 10mm (head) bolts attaching the lower radiator support to the frame to allow clearance (Fig.V). Now, align the pre-existing hole in the lowermost mount of the main receiver brace with the holes in the bottom and top of the subframe. Using the lowermost mount as a template, use a  $\frac{1}{2}$ " drill of appropriate length to drill out the holes in the bottom and top of the subframe.

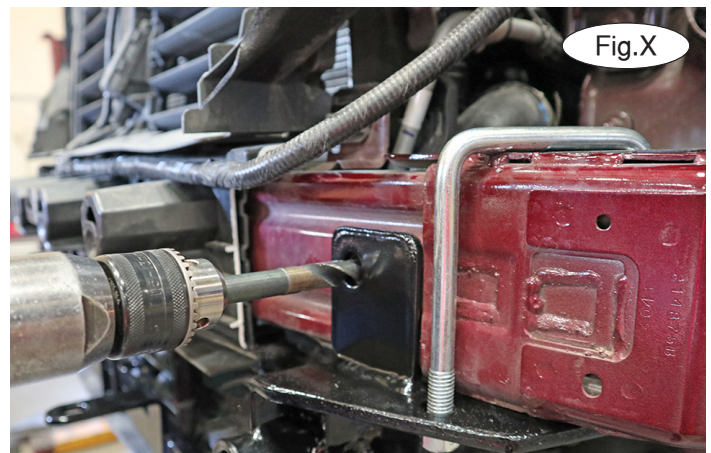
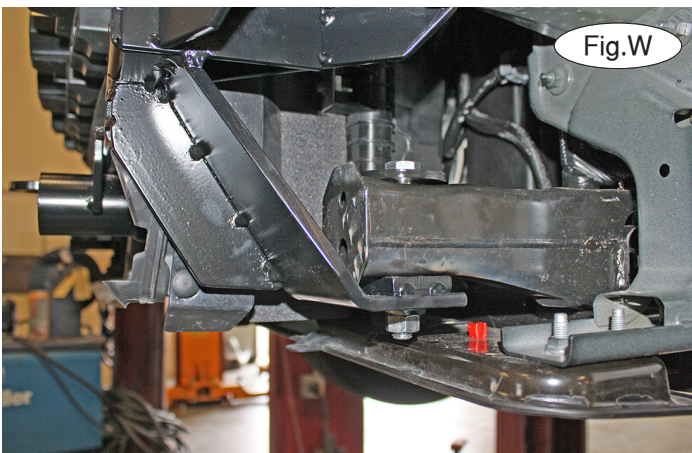

15. On each side, place a  $\frac{1}{2}$ " plate washer and square spacer with offset hole over a  $\frac{1}{2}$ " x 4" bolt and bolt down through the subframe and main receiver brace. Finish with a  $\frac{1}{2}$ " lock washer and nut (Fig.W). *Note:* Due to manufacturing variances, some applications may require bolting up through the main receiver brace and subframe instead.

16. On each side, use the upper mount of the baseplate as a guide and drill a  $\frac{17}{32}$ " hole through the bumper core (Fig.X). *Note:* Use caution and a piece of metal as a buffer to ensure that you don't drill into the engine components.

17. On each side, place one of the angled and nitted plates behind the baseplate, aligning it with the hole you drilled in the previous step (Fig.Y). Then, place a  $\frac{1}{2}$ " lock washer and a  $\frac{1}{2}$ " flat washer over a  $\frac{1}{2}$ " x  $3\frac{1}{2}$ " bolt and pass it through the baseplate and hole you drilled in the previous step, and into the plate (Fig.Z – next page).

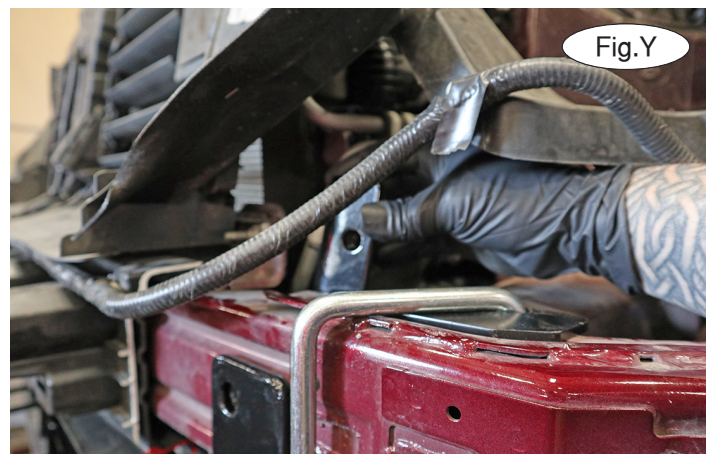



# BASEPLATE KIT INSTALLATION INSTRUCTIONS

**KIT# 524444-4**

08/18/22  
KS

ROADMASTER, Inc. 6110 NE 127th Ave. Vancouver, WA 98682 360-896-0407 fax 360-735-9300 www.roadmasterinc.com

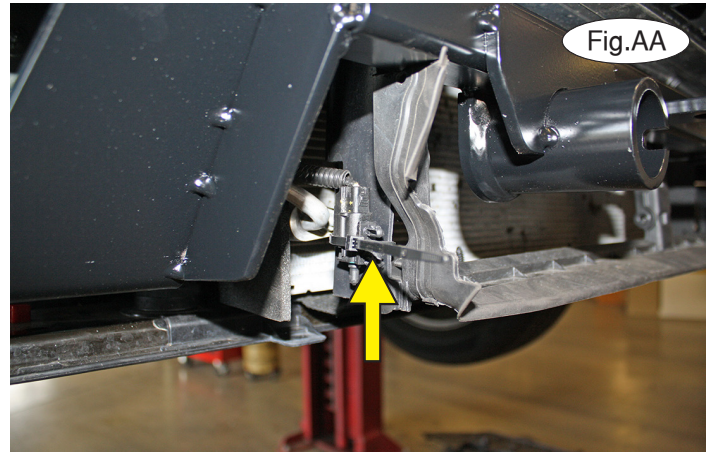

18. Ziptie the ambient temperature sensor to the side of the air dam (Fig.AA).

19. On the backside of the fascia on each side, disconnect two of the fasteners of the wiring loom, leaving the center of the loom still connected (Fig.BB). Use an approximately 3/16" drill bit and drill a hole through the upper flange of the grille opening directly in front of the wiring loom fastener (Fig.BB). *Note:* ensure that the hole cannot be seen from the front of the vehicle.

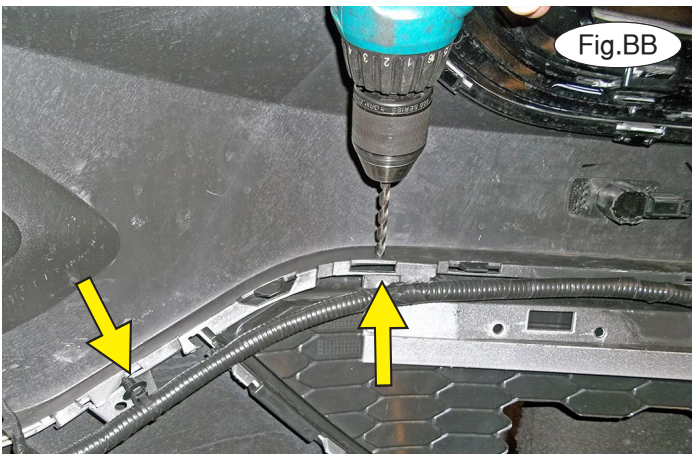

20. Remount the wiring loom using the hole you drilled in the previous step (Fig.CC).

21. Tighten all bolts to the bolt torque requirements found at the end of these instructions. *Note:* use Loctite® Red on all nuts and bolts.



# BASEPLATE KIT INSTALLATION INSTRUCTIONS

**KIT# 524444-4**

08/18/22  
KS

ROADMASTER, Inc. 6110 NE 127th Ave. Vancouver, WA 98682 360-896-0407 fax 360-735-9300 www.roadmasterinc.com

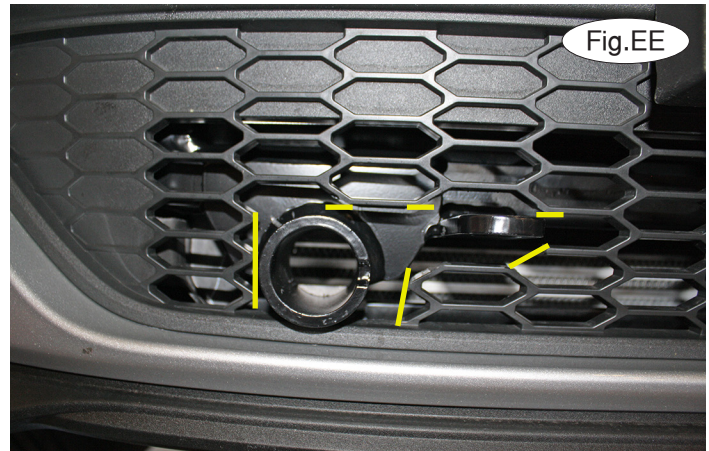
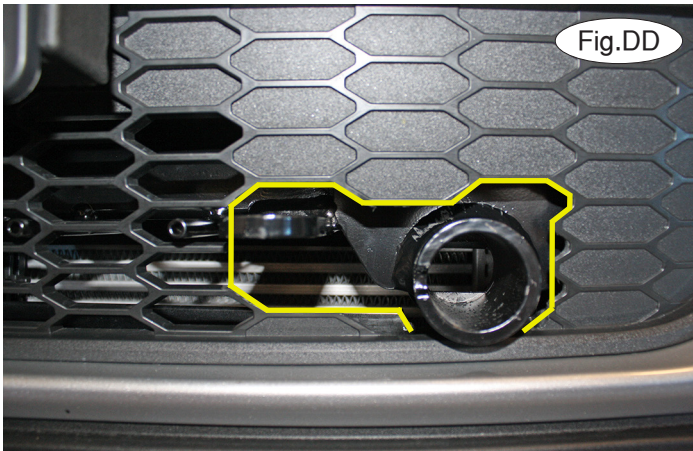

22. **For Sport models:** trim the fascia using the yellow lines as a reference (Fig.DD – driver's side, Fig.EE (next page) – passenger side). **For all other models:** Trim using the yellow lines in Figure FF as a reference.

23. Reinstall the fascia, reversing steps 1 through 6.

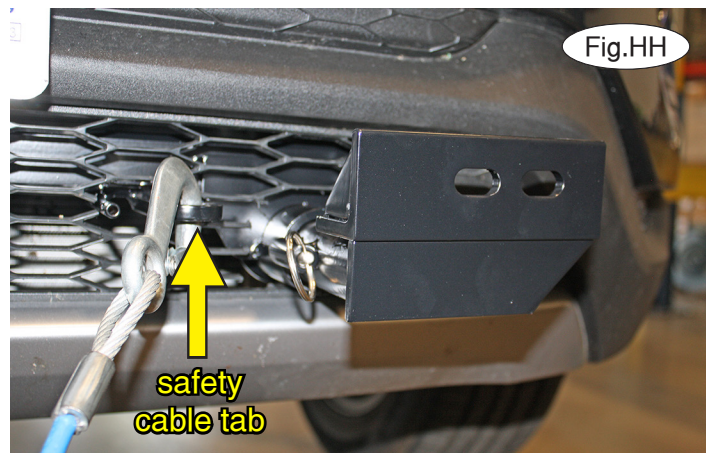
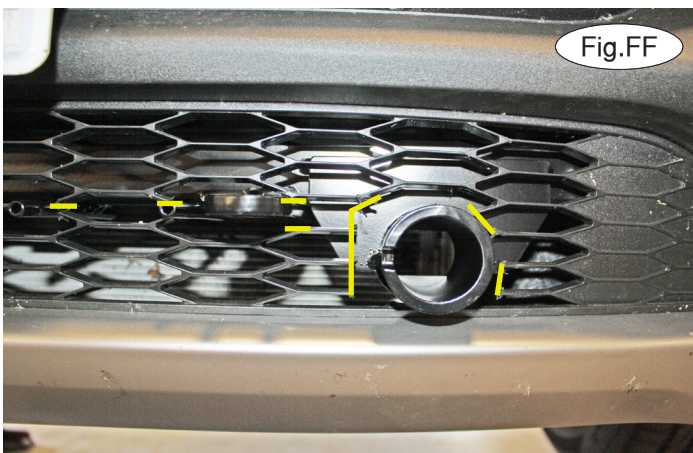

24. On each side, insert the removable front arm into the front receiver 90 degrees from its final towing position, depressing the spring-loaded pin against the receiver. Twist back 90 degrees until the spring-loaded pin snaps into place in the notch on the receiver, locking the arm into place in its final towing position. **Please note: it is the owner's responsibility to ensure the locking of the pins before towing. Otherwise, failure of the towing system will result.**

25. Install the tow bar to the mounting bracket according to the manufacturer's instructions.

## **IMPORTANT!**

**Safety cables are required by law. When towing, connect safety cables to the safety cable tabs illustrated on the first page and in Figure HH. Make certain there is adequate slack in the cables to allow a full turning radius; otherwise, damage will result. If necessary, longer cables or cable extensions are available.**

26. Install the tow bar to the mounting bracket according to the manufacturer's instructions.



# BASEPLATE KIT INSTALLATION INSTRUCTIONS

**KIT# 524444-4**

08/18/22  
KS

ROADMASTER, Inc. 6110 NE 127th Ave. Vancouver, WA 98682 360-896-0407 fax 360-735-9300 www.roadmasterinc.com

## Three options for attaching the wiring plug to the main receiver brace

**For six-wire plugs:** use the two supplied 3/4" self-tapping screws to attach the electrical plug directly to the rods on the front of the main receiver brace.

**For four-wire round plugs:** attach to the plug mounting plate and then use the two supplied 3/4" self-tapping screws to attach the mounting plate to the rods on the front of the main receiver brace.

**For four-wire flat plugs:** place the plug through the mounting plug plate, and then secure it using the supplied zip tie on the front of the plug (Fig.II). Use the two supplied 3/4" self-tapping screws to attach the mounting plate to the rods on the front of the main receiver brace.

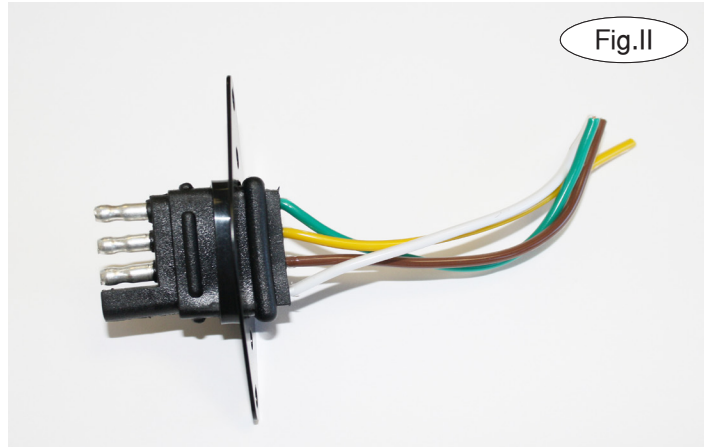

## BOLT TORQUE REQUIREMENTS

Note: The torque values represented below are intended as general guidelines. Torque requirements for specific applications may vary. Roadmaster does not warrant this information to be accurate for all applications and disclaims all liability for any claims or damages which may result from its use.

### STANDARD BOLTS

Thread Size	Grade	Torque
5/16.....	5.....	13 ft./lb.
3/8.....	5.....	23 ft./lb.
7/16.....	5.....	37 ft./lb.
1/2.....	5.....	56 ft./lb.
5/8.....	5.....	150 ft./lb.

### METRIC BOLTS

Thread Size	Grade	Plated / Unplated
8mm-1.0.....	8.8.....	20 ft./lb. 18 ft./lb.
8mm-1.25.....	8.8.....	19 ft./lb. 18 ft./lb.
10mm-1.25.....	8.8.....	38 ft./lb. 36 ft./lb.
10mm-1.5.....	8.8.....	37 ft./lb. 35 ft./lb.

### METRIC BOLTS

Thread Size	Grade	Plated / Unplated
12mm-1.25.....	8.8.....	70 ft./lb. 65 ft./lb.
12mm-1.5.....	8.8.....	66 ft./lb. 61 ft./lb.
12mm-1.75.....	8.8.....	65 ft./lb. 60 ft./lb.
14mm-2.0.....	8.8.....	104 ft./lb. 97 ft./lb.

All illustrations and specifications contained herein are based on the latest information available at the time of publication approval. ROADMASTER, INC. reserves the right to make changes at any time without notice in material, specification and models or to discontinue models.