



# BASEPLATE KIT INSTALLATION INSTRUCTIONS

**KIT# 524449-5**

04/02/17  
KS

ROADMASTER, Inc. 6110 NE 127th Ave. Vancouver, WA 98682 360-896-0407 fax 360-735-9300 www.roadmasterinc.com

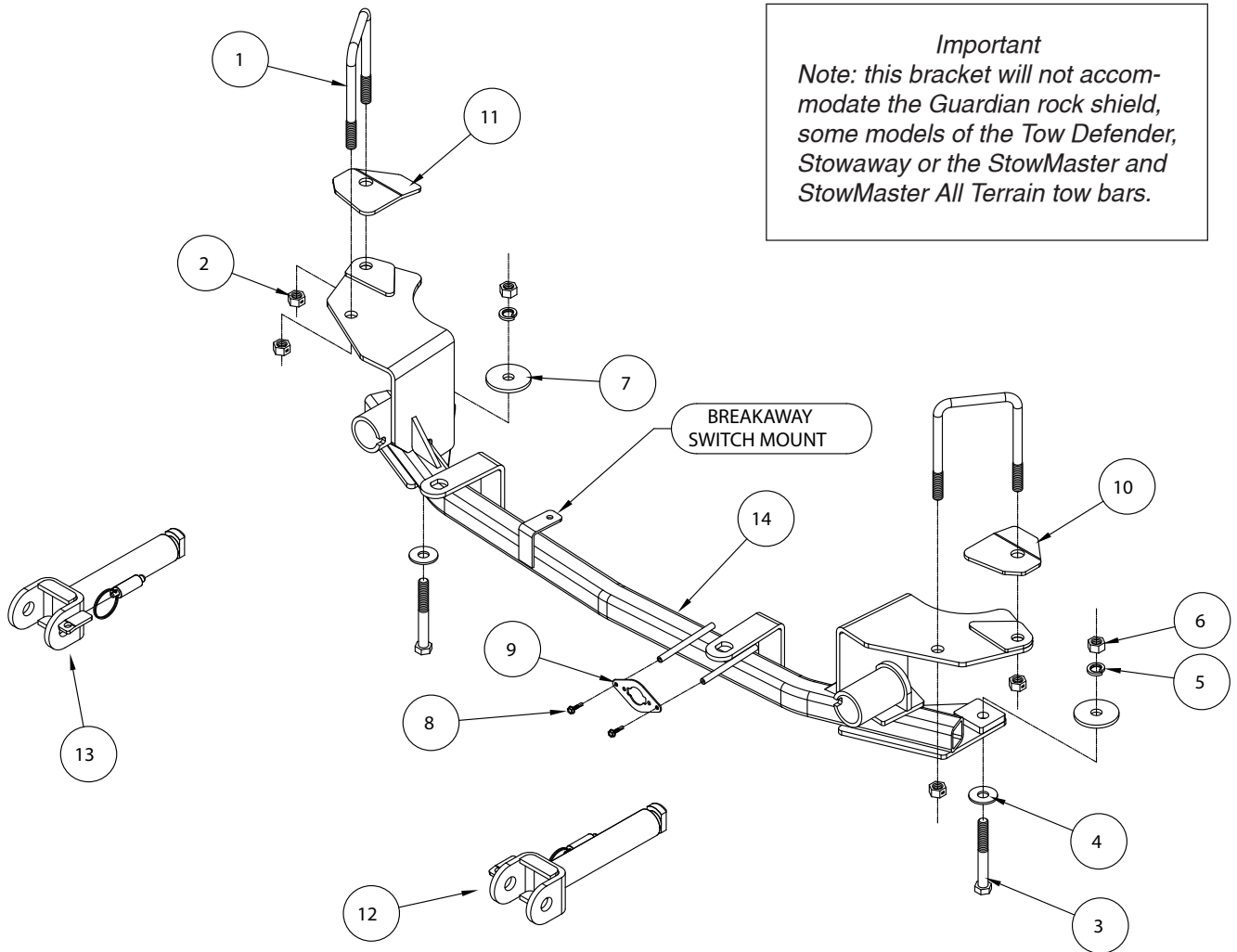

*Important*  
Note: this bracket will not accommodate the Guardian rock shield, some models of the Tow Defender, Stowaway or the StowMaster and StowMaster All Terrain tow bars.

ITEM	QTY	NAME	PART #
1	2	1/2" x 3 1/2" x 5 1/2" U-BOLT	357021-50
2	4	1/2" TWO WAY LOCKNUT	350258-20
3	2	1/2" x 4" BOLT	350105-00
4	2	1/2" FLAT WASHER	350308-00
5	2	1/2" LOCK WASHER	350309-00
6	2	1/2" NUT	350258-00
7	2	1/2" PLATE WASHER	A-003086
8	2	#10 x 3/4" SELF DRILLING SCREW	350247-35
9	1	WIRE PLUG PLATE	A-003801
10	1	DRIVER SIDE SHIM PLATE	B-002900
11	1	PASSENGER SIDE SHIM PLATE	B-002901
12	1	DRIVER SIDE ARM	C-002383
13	1	PASSENGER SIDE ARM	C-002384
14	1	MAIN RECEIVER	C-003098
15	1	ZIP TIE	300140-8



# BASEPLATE KIT INSTALLATION INSTRUCTIONS

**KIT# 524449-5**

04/02/17  
KS

ROADMASTER, Inc. 6110 NE 127th Ave. Vancouver, WA 98682 360-896-0407 fax 360-735-9300 www.roadmasterinc.com

This is one of our EZ5 Twistlock series brackets, which allows the visible front portion of the bracket to be easily removed from the front of the vehicle (Fig.A and Fig.B). The bracket consists of a main receiver brace, two removable front braces, and a hardware pack.

The main receiver brace mounts to the bumper core and subframe. The removable front braces install in the main receiver brace.

Before starting the installation, lay out the kit components in order, as they will be used. This will give you a visual idea of how the components work, and will also confirm that everything is present and accounted for.



**IMPORTANT:** All baseplates **must** be assembled with all the bolts left loose for final adjustment and positioning (before tightening) unless otherwise instructed. All bolts **must** be torqued for proper strength. If more than one bolt is used per fastening point, the diagram may only show one. Use flat washers over all slotted holes and lock washers on all fasteners.

## WARNING

Failure to heed these warnings or follow the installation instructions may result in a voided warranty, loss of towed vehicle, personal injury or death.

- Do not weld or modify this baseplate or its components. Welding or modification will void the warranty.
- Do not use this document as a basis to design/fabricate a baseplate, as it may not show all parts or structural components.
- We strongly recommend professional installation.
- If the towed vehicle has been in an accident, it must be properly repaired before attaching the baseplate. Do not install the baseplate if any structural frame damage is found.
- The installer must use all bolts and parts supplied. If running changes were made by the vehicle manufacturer after this kit was designed, some bolts or other fasteners may no longer be the correct size. It is the installer's responsibility to verify this kit is securely fastened to the vehicle.
- Use Loctite® Red on all bolts used to secure this baseplate. Torque all bolts to the specifications found at the end of these instructions. Do not over-torque the bolts or failure may occur.
- The installer must inspect the baseplate to ensure adequate clearance, particularly around hoses, air conditioner lines, radiators, etc. or non-warranty failure may result.
- Roadmaster manufactures many styles of baseplates. If your baseplate has removable arms, they must be removed before driving the vehicle, unless the arms can be pinned or padlocked in place. If not secured, the arms could vibrate out.
- Some motorhome chassis have such a tight turning radius that you can damage your motorhome, towed vehicle, tow bar or baseplate while turning sharply. Before getting on the road, test your turning radius in an empty parking lot. Turning too sharply could result in non-warranty damage to your towing system, motorhome and/or towed vehicle.
- Do not back up with the towed vehicle attached or non-warranty damage will occur to your towing system or vehicles.
- The safety cables must connect the towing vehicle to the towed vehicle frame to frame, with the cables crossed, with enough slack for sharp turns. See cable instructions for proper routing. Failure to do so will result in non-warranty damage and/or the loss of the towed vehicle.
- This kit is designed for use with ROADMASTER tow bars and ROADMASTER adapters only. Using this kit with other brands, without an approved ROADMASTER adapter, may result in non-warranty damage or injury.
- Receiver extensions and out-of-level towing situations of 3 inches or more. This can cause the system to swing much higher and lower, causing excessive strain on the tow bar, baseplate and frame. That can cause the towing system to fail, causing property damage, personal injury or even death. If you must use a receiver extension or drop hitch to tow, it will reduce your receiver's weight capacity by 1/3 to avoid damaging your system. Never use more than one extension and/or drop hitch, as this will void your warranty.
- Every 3,000 miles, the owner must inspect all mounting points for cracks or fatigue, and check the fasteners for proper torque, according to the bolt torque requirements chart on the last page of these instructions.
- The owner must follow the vehicle manufacturer's instructions to prepare the vehicle for towing. Failure to do so may cause severe damage to the vehicle.
- This baseplate is only warranted for the original installation. Installing a used baseplate on another vehicle is not recommended and will void the warranty.



# BASEPLATE KIT INSTALLATION INSTRUCTIONS

**KIT# 524449-5**

04/02/17  
KS

ROADMASTER, Inc. 6110 NE 127th Ave. Vancouver, WA 98682 360-896-0407 fax 360-735-9300 www.roadmasterinc.com

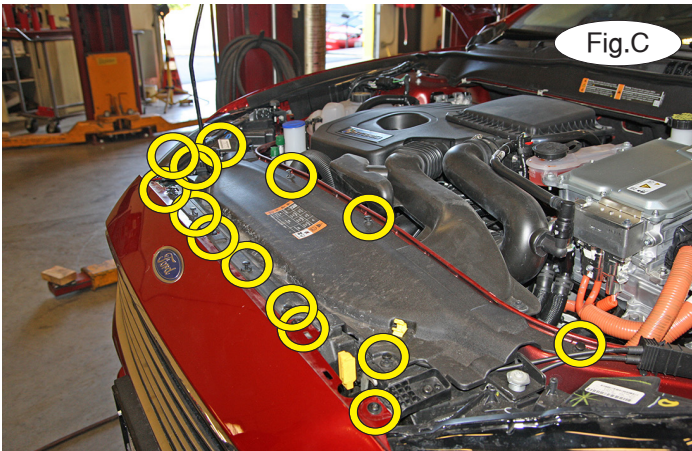

1. **Important:** please use all supplied bolts and parts and read all instructions carefully before beginning this installation. The majority of questions you may have can be answered within the text, and proper installation will ensure safe and secure travel. Now, begin the installation. Remove nine plastic fasteners attaching the radiator cover to the fascia and five 10mm (head) bolts attaching the top of the fascia to the core support (Fig.C).

2. On each side, remove two 7mm (head) screws and one plastic fastener attaching the fender liner to the fascia (Fig.D).

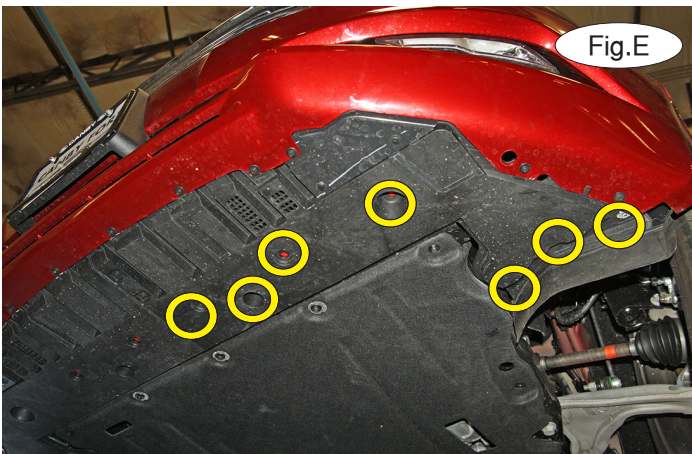

3. On each side, remove four 10mm (head) screws and three 7mm (head) screws attaching the fender liner to the core support (Fig.E).

4. On each side, remove six 7mm (head) screws attaching the splash shield to the core support and fascia. They are located along the forward edge of the splash shielding. Then, remove the splash shielding (Fig.F).

5. Remove two 10mm (head) bolts and two plastic fasteners attaching the lower air dam to the bottom of the louver housing (Fig.G).

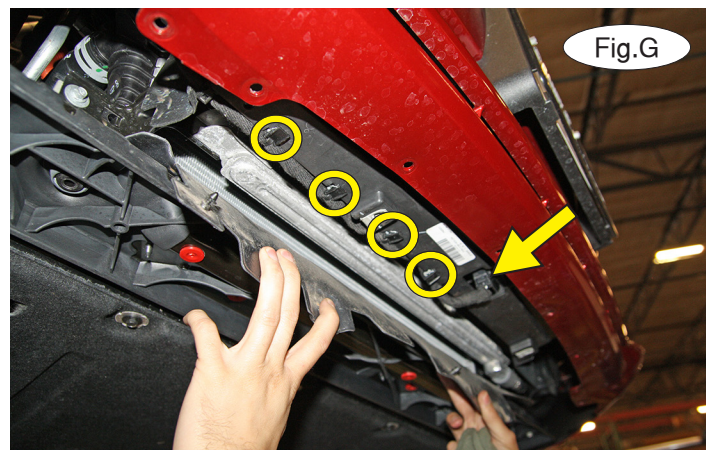



# BASEPLATE KIT INSTALLATION INSTRUCTIONS

**KIT# 524449-5**

04/02/17  
KS

ROADMASTER, Inc. 6110 NE 127th Ave. Vancouver, WA 98682 360-896-0407 fax 360-735-9300 www.roadmasterinc.com



7. On the driver's side, unplug two electrical connectors (Fig.H).
8. On each side, remove one 10mm (head) nut attaching the fender liner to the wheel well (Fig.I).
9. On each side, pull back the fender liner, removing it from its stud. Then, remove two 8mm (head) bolts attaching the fascia to the fender (Fig.J).

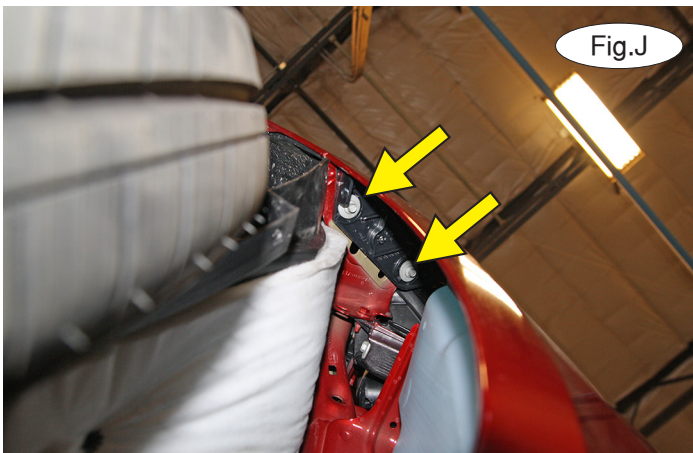

10. On each side, pull down at the seam to release the fascia's alignment pins (Fig.K).
11. On each side, completely trim off the vertical side wall of the louver housing so that it is flush with the face of the louver housing. Use the yellow lines in Figure L as a guide for trimming.
12. On each side, use a cut-off wheel to trim off the tab as indicated in Figure M.

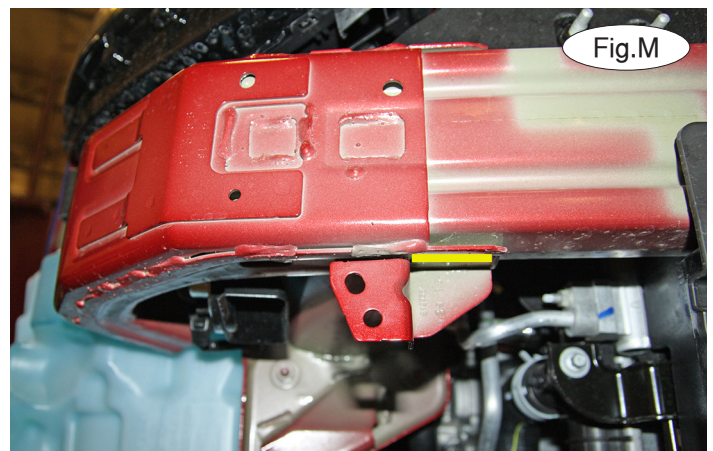
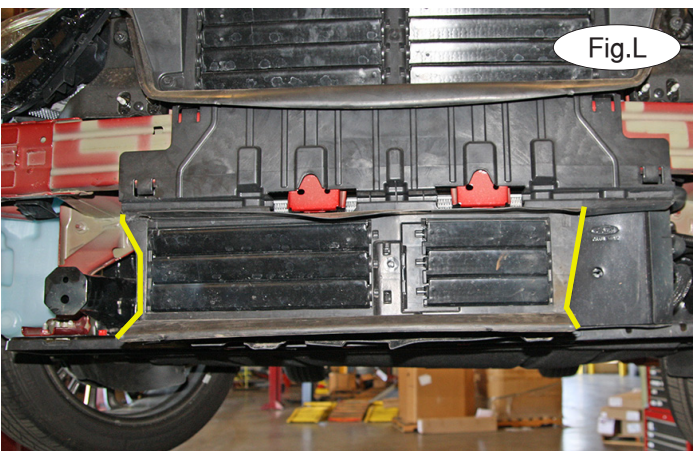



# BASEPLATE KIT INSTALLATION INSTRUCTIONS

**KIT# 524449-5**

04/02/17  
KS

ROADMASTER, Inc. 6110 NE 127th Ave. Vancouver, WA 98682 360-896-0407 fax 360-735-9300 www.roadmasterinc.com

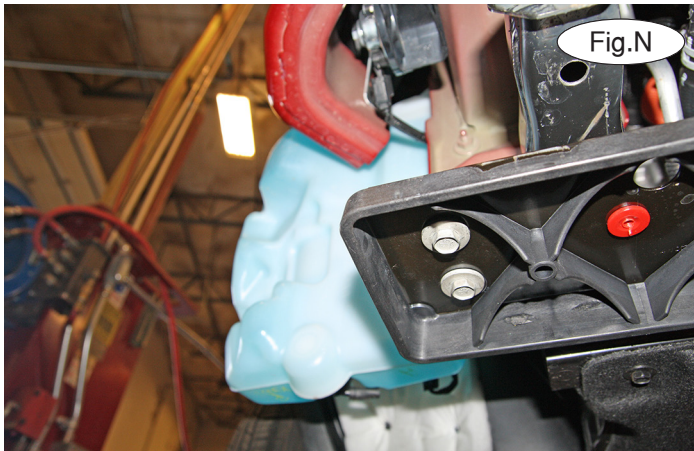

13. On each side, remove two 10mm (head) bolts attaching the lower radiator support to the frame to allow clearance (Fig.N). Let it hang down for now. Use a 1/2" drill of appropriate length to drill out the holes in the bottom and top of the sub-frame (Fig.O).

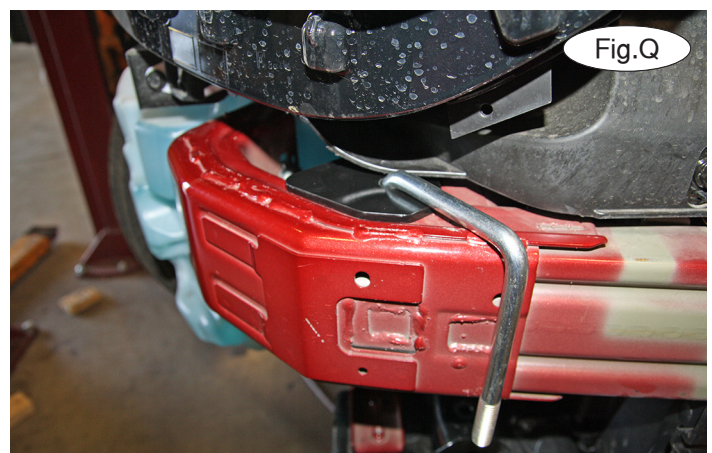

14. On each side, place the supplied U bolt through the shim plate, with the center bend pointing up (Fig.P) and then place the U bolt around the outside of the bumper core, and slide it into position as shown in Figure Q.

15. On each side, place the main receiver brace under the bumper core and over the U bolts and then thread on the 1/2" two-way locknuts (Fig.R). *Note:* the two-way locknuts have a dimple on the side and are self-locking. *Note:* ensure that wiring looms are not being pinched between the bracket and frame.





# BASEPLATE KIT INSTALLATION INSTRUCTIONS

**KIT# 524449-5**

04/02/17  
KS

ROADMASTER, Inc. 6110 NE 127th Ave. Vancouver, WA 98682 360-896-0407 fax 360-735-9300 www.roadmasterinc.com

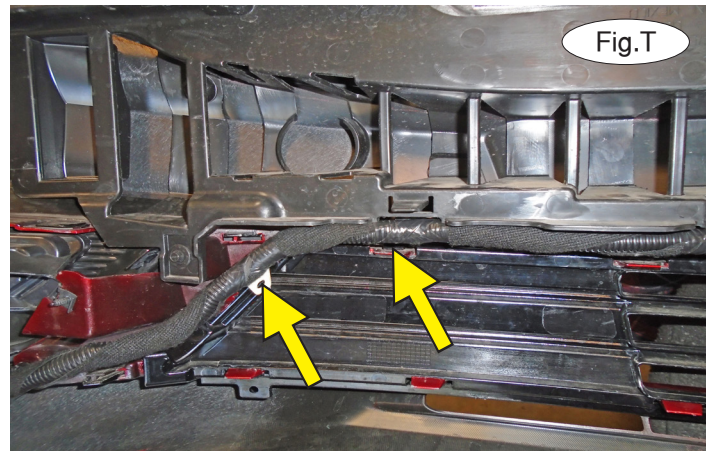
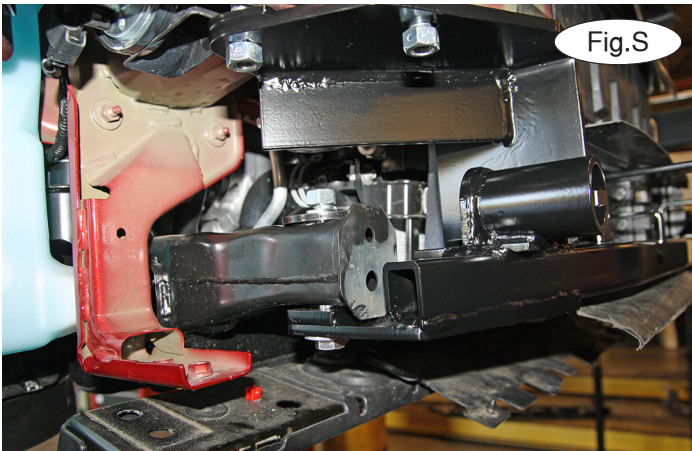

16. On each side, use one of the supplied  $\frac{1}{2}$ " x 4" bolts and  $\frac{1}{2}$ " washer and bolt up through the main receiver brace and the subframe. Finish with a  $\frac{1}{2}$ " plate washer, lock washer and nut (Fig.S).

17. Make certain that all the mounting hardware is sufficiently loose, and if the bracket is angled downward, tighten the forwardmost U bolt nut until the bracket is approximately level. You can adjust the front or back U bolt nuts accordingly to achieve this. Tighten all bolts to the bolt torque requirements found at the end of these instructions. *Note:* use Loctite® Red on all nuts and bolts.

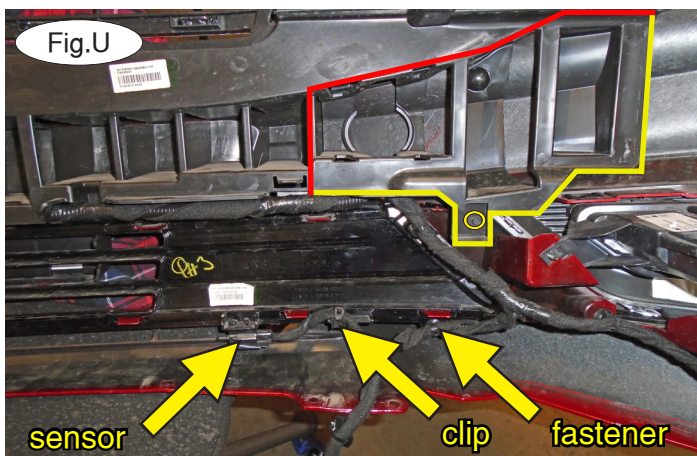

18. On the driver's side of the fascia, disconnect the wiring harness by removing two plastic fasteners at the upper corner of the grille opening (Fig.T – arrows). They will need to be tucked around the grille opening upon reinstallation of the fascia. On the passenger side, remove the ambient temperature sensor and the clip on its harness from the back of the grille (Fig.U – arrows). Now, trim the clips and sensor mounts flush with the back of the grille, and then zip tie the ambient temperature sensor back to the fastener (Fig.U – arrow).

Then, on each side, remove the 10mm (head) bolt attaching the shock absorption pad (Fig.U – circle).

Now, on each side, trim away the shock absorption pad. The red lines in Figure U show the trimming and the yellow lines outline the section that is being removed.

19. Cut out the templates at the end of these instructions. Tape them in place over the fascia (Fig.V) and then mark the hole on the template and trim the fascia. The final trimming is shown in Figure W. *Note:* You will need to trim on the driver's side to allow clearance for the wiring plug rods and on both sides for the safety cable tab (Fig.W – driver's side, inset).



# BASEPLATE KIT INSTALLATION INSTRUCTIONS

**KIT# 524449-5**

04/02/17  
KS

ROADMASTER, Inc. 6110 NE 127th Ave. Vancouver, WA 98682 360-896-0407 fax 360-735-9300 www.roadmasterinc.com

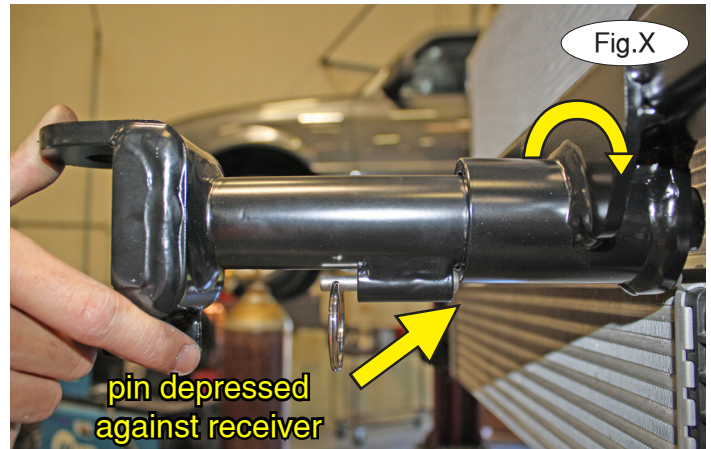
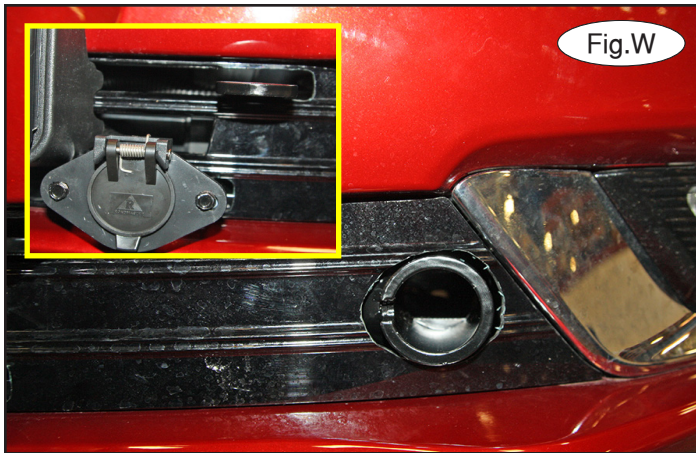

20. Reinstall the radiator support and the fascia, reversing steps 12, and then 1-10.

21. **Note: the following two images are for illustration purposes only, as your specific application may be slightly different.** On each side, insert the removable front bracket arm into the front receiver 90 degrees from its final towing position, depressing the spring-loaded pin against the receiver (Fig.X). Now, twist back 90 degrees until the spring-loaded pin snaps into place in the notch on the receiver, locking the arm into place in its final towing position (Fig.Y).

**Please note: it is the owner's responsibility to ensure the locking of the pins before towing. Otherwise, failure of the towing system will result.**

23. Install the tow bar to the mounting bracket according to the manufacturer's instructions.

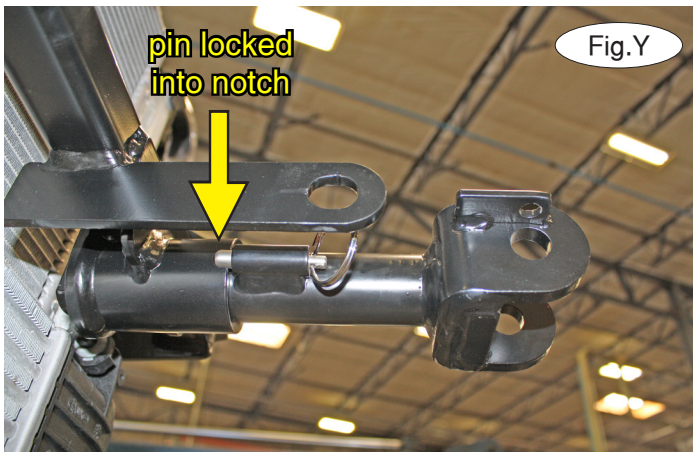

## **IMPORTANT!**

**Safety cables are required by law. When towing, connect safety cables to the safety cable tabs illustrated in Figure Z. Make certain there is adequate slack in the cables to allow a full turning radius; otherwise, damage will result. If necessary, longer cables or cable extensions are available.**



# BASEPLATE KIT INSTALLATION INSTRUCTIONS

**KIT# 524449-5**

04/02/17  
KS

ROADMASTER, Inc. 6110 NE 127th Ave. Vancouver, WA 98682 360-896-0407 fax 360-735-9300 www.roadmasterinc.com

## Three options for attaching the wiring plug to the main receiver brace

**For six-wire plugs:** use the two supplied 3/4" self-tapping screws to attach the electrical plug directly to the rods on the front of the main receiver brace.

**For four-wire round plugs:** attach to the plug mounting plate and then use the two supplied 3/4" self-tapping screws to attach the mounting plate to the rods on the front of the main receiver brace.

**For four-wire flat plugs:** place the plug through the mounting plug plate, and then secure it using the supplied zip tie on the front of the plug (Fig.AA). Use the two supplied 3/4" self-tapping screws to attach the mounting plate to the rods on the front of the main receiver brace.

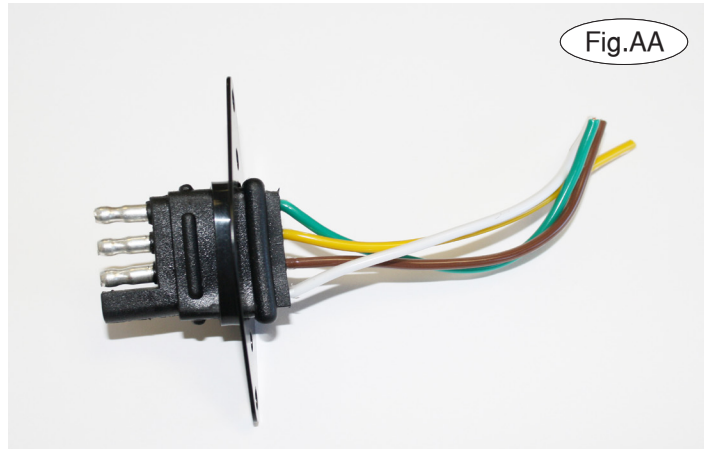

Fig.AA

### BOLT TORQUE REQUIREMENTS

Note: The torque values represented below are intended as general guidelines. Torque requirements for specific applications may vary. Roadmaster does not warrant this information to be accurate for all applications and disclaims all liability for any claims or damages which may result from its use.

#### STANDARD BOLTS

Thread Size	Grade	Torque
5/16-18	5	13 ft./lb.
3/8-16	5	23 ft./lb.
7/16-14	5	37 ft./lb.
1/2-13	5	57 ft./lb.
5/8-11	5	112 ft./lb.

#### METRIC BOLTS

Thread Size	Grade	Torque
6mm-1.0	8.8	6 ft./lb.
8mm-1.0	8.8	18 ft./lb.
8mm-1.25	8.8	16 ft./lb.
10mm-1.25	8.8	36 ft./lb.
10mm-1.5	8.8	31 ft./lb.

#### METRIC BOLTS

Thread Size	Grade	Torque
12mm-1.25	8.8	64 ft./lb.
12mm-1.5	8.8	60 ft./lb.
12mm-1.75	8.8	55 ft./lb.
14mm-2.0	8.8	88 ft./lb.

All illustrations and specifications contained herein are based on the latest information available at the time of publication approval. ROADMASTER, INC. reserves the right to make changes at any time without notice in material, specification and models or to discontinue models.



# BASEPLATE KIT INSTALLATION INSTRUCTIONS

**KIT# 524449-5**

04/02/17  
KS

ROADMASTER, Inc. 6110 NE 127th Ave. Vancouver, WA 98682 360-896-0407 fax 360-735-9300 www.roadmasterinc.com

## Trimming templates

