



BASEPLATE KIT INSTALLATION INSTRUCTIONS

KIT# 524469-4

08/16/23
KS

ROADMASTER, Inc. 6110 NE 127th Ave. Vancouver, WA 98682 360-896-0407 fax 360-735-9300 www.roadmasterinc.com

Second person to assist
T40 Torx driver
10mm deep socket
15mm socket
Ratchets

What You'll Need

9/16" bit and drill
(2) 3/4" wrenches
Permanent marker

Panel tool
Tape measure
Reciprocating saw
Torque wrench
Loctite© Red or Blue

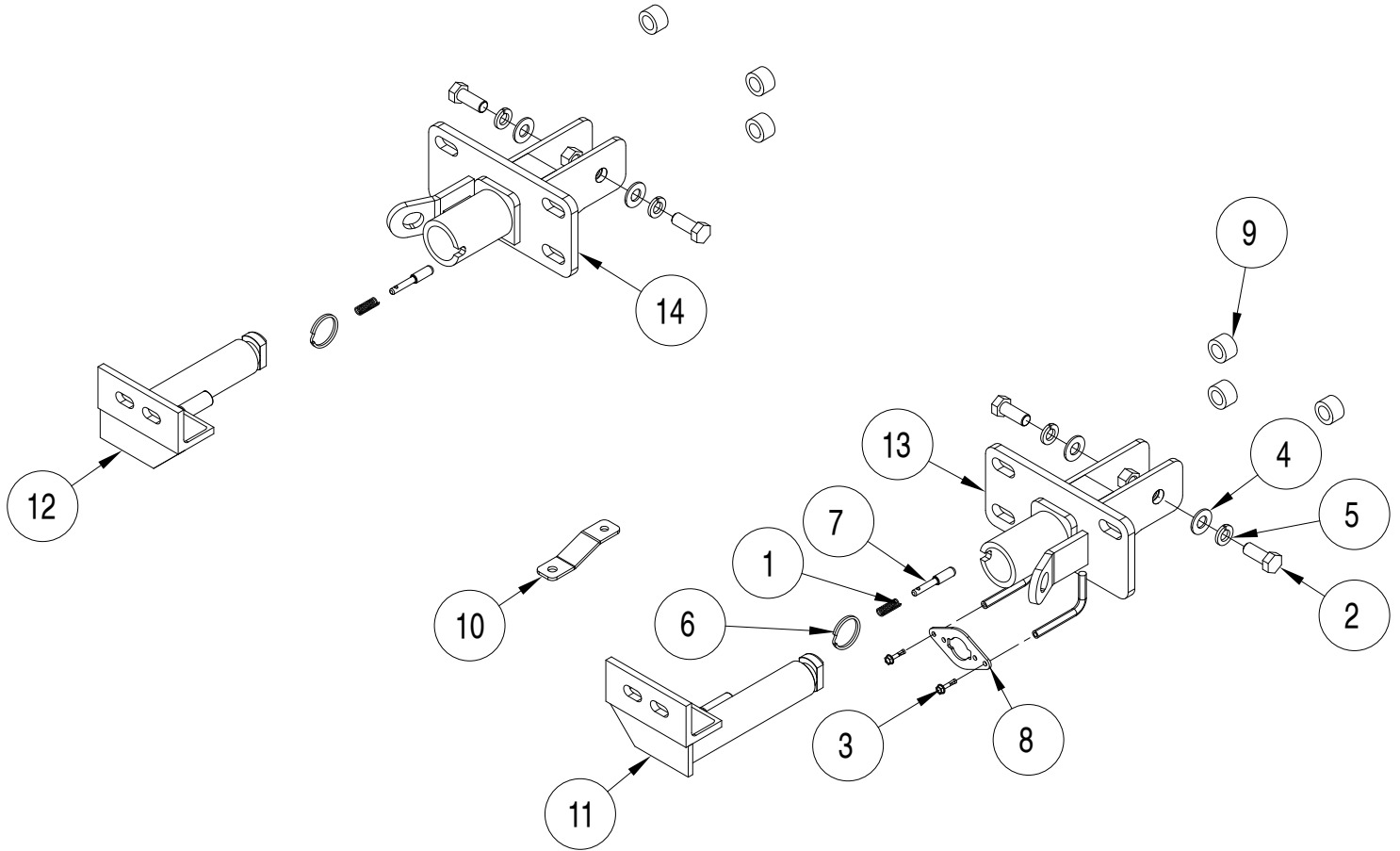

ITEM	QTY	DESCRIPTION	PART NUMBER
1	2	SPRING	200146-00
2	4	1/2" x 1 1/4" BOLT	350094-00
3	2	#10 x 3/4" SELF DRILLING SCREW	350247-35
4	4	1/2" SAE WASHER	350308-20
5	4	1/2" LOCK WASHER	350309-00
6	2	RING	350520-00
7	2	LOCK PIN	A000008
8	1	WIRE PLUG PLATE	A003801
9	6	1" O.D. X 0.188" WALL X 13/16" SPACER	A006239
10	1	BRAKEAWAY MOUNT	B004032
11	1	DRIVER SIDE ARM	C003648
12	1	PASSENGER SIDE ARM	C003649
13	1	DRIVER SIDE RECEIVER	C003650
14	1	PASSENGER SIDE RECEIVER	C003651



BASEPLATE KIT INSTALLATION INSTRUCTIONS

KIT# 524469-4

08/16/23
KS

ROADMASTER, Inc. 6110 NE 127th Ave. Vancouver, WA 98682 360-896-0407 fax 360-735-9300 www.roadmasterinc.com

This is one of our crossbar-style baseplates, which allows the visible front portion of the baseplate to be easily removed from the front of the vehicle (Fig.A and Fig.B).

The kit mounts to the frame of the vehicle, and consists of two main braces, two removable front braces, and a hardware pack.

Before starting the installation, lay out the kit components in order, as they will be used. This will give you a visual idea of how the components work, and will also confirm that everything is present and accounted for.



IMPORTANT: All baseplates **must** be assembled with all the bolts left loose for final adjustment and positioning (before tightening) unless otherwise instructed. All bolts **must** be torqued for proper strength. If more than one bolt is used per fastening point, the diagram may only show one. Use flat washers over all slotted holes and lock washers on all fasteners.

WARNING

Failure to heed these warnings or follow the installation instructions may result in a voided warranty, loss of towed vehicle, personal injury or death.

- Do not weld or modify this baseplate or its components. Welding or modification will void the warranty.
- Do not use this document as a basis to design/fabricate a baseplate, as it may not show all parts or structural components.
- We strongly recommend professional installation.
- If the towed vehicle has been in an accident, it must be properly repaired before attaching the baseplate. Do not install the baseplate if any structural frame damage is found.
- The installer must use all bolts and parts supplied. If running changes were made by the vehicle manufacturer after this kit was designed, some bolts or other fasteners may no longer be the correct size. It is the installer's responsibility to verify this kit is securely fastened to the vehicle.
- Use Loctite® Red on all bolts used to secure this baseplate. Torque all bolts to the specifications found at the end of these instructions. Do not over-torque the bolts or failure may occur.
- The installer must inspect the baseplate to ensure adequate clearance, particularly around hoses, air conditioner lines, radiators, etc. or non-warranty failure may result.
- Roadmaster manufactures many styles of baseplates. If your baseplate has removable arms, they must be removed before driving the vehicle, unless the arms can be pinned or padlocked in place. If not secured, the arms could vibrate out.
- Some motorhome chassis have such a tight turning radius that you can damage your motorhome, towed vehicle, tow bar or baseplate while turning sharply. Before getting on the road, test your turning radius in an empty parking lot. Turning too sharply could result in non-warranty damage to your towing system, motorhome and/or towed vehicle.
- Do not back up with the towed vehicle attached or non-warranty damage will occur to your towing system or vehicles.
- The safety cables must connect the towing vehicle to the towed vehicle frame to frame, with the cables crossed, with enough slack for sharp turns. See cable instructions for proper routing. Failure to do so will result in non-warranty damage and/or the loss of the towed vehicle.
- This kit is designed for use with ROADMASTER tow bars and ROADMASTER adapters only. Using this kit with other brands, without an approved ROADMASTER adapter, may result in non-warranty damage or injury.
- Receiver extensions and out-of-level towing situations of 3 inches or more. This can cause the system to swing much higher and lower, causing excessive strain on the tow bar, baseplate and frame. That can cause the towing system to fail, causing property damage, personal injury or even death. If you must use a receiver extension or drop hitch to tow, it will reduce your receiver's weight capacity by 1/3 to avoid damaging your system. Never use more than one extension and/or drop hitch, as this will void your warranty.
- Every 3,000 miles, the owner must inspect all mounting points for cracks or fatigue, and check the fasteners for proper torque, according to the bolt torque requirements chart on the last page of these instructions.
- The owner must follow the vehicle manufacturer's instructions to prepare the vehicle for towing. Failure to do so may cause severe damage to the vehicle.
- This baseplate is only warranted for the original installation. Installing a used baseplate on another vehicle is not recommended and will void the warranty.



BASEPLATE KIT INSTALLATION INSTRUCTIONS

KIT# 524469-4

08/16/23
KS

ROADMASTER, Inc. 6110 NE 127th Ave. Vancouver, WA 98682 360-896-0407 fax 360-735-9300 www.roadmasterinc.com

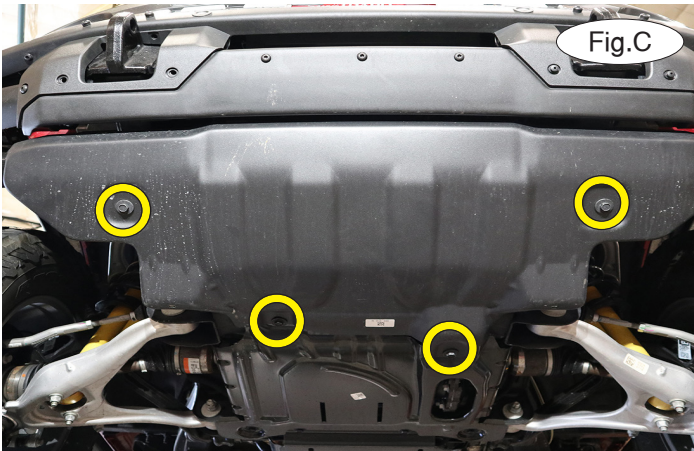

Important: Please use all supplied bolts and parts and read all instructions carefully before beginning this installation. The majority of questions you may have can be answered within the text, and proper installation will ensure safe and secure travel.

1. With the assistance of a second person, remove four 15mm bolts attaching the skidplate to the subframe and bumper mounts (Fig.C). Carefully lower the skidplate and set it aside for now.

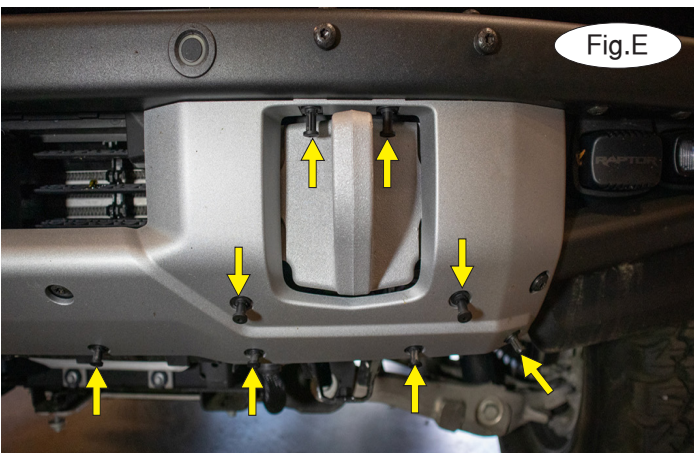

2. On each side, remove four push pins attaching the tow hook cover to the bumper (Fig.D). Pull out firmly to release each tow hook cover (Fig.E) and set them aside for now. *Note: Raptor models have eight fasteners attaching the front skid plate to the bumper that will need to be removed instead (Fig.F).*

3. With the assistance of a second person, on each side, remove three 15mm bolts attaching the tow hook and bumper to the frame (Fig.G). Unplug the wiring harness on the driver's side (Fig.H) and then set the bumper aside.

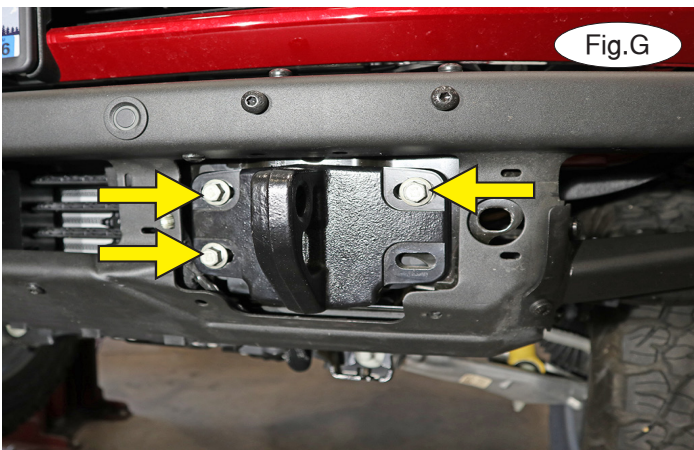



BASEPLATE KIT INSTALLATION INSTRUCTIONS

KIT# 524469-4

08/16/23
KS

ROADMASTER, Inc. 6110 NE 127th Ave. Vancouver, WA 98682 360-896-0407 fax 360-735-9300 www.roadmasterinc.com

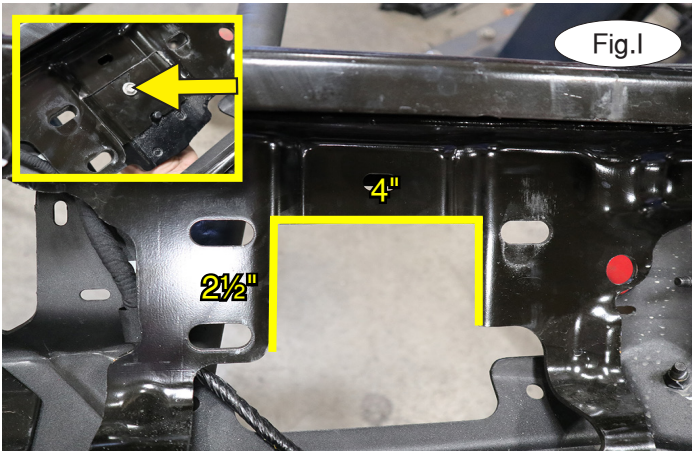

4. On the back side of the bumper, on each side, remove one 10mm bolt attaching the tow hook to the bumper (Fig.I – inset). Then, trim a 2.5" x 4" piece of the bumper using a cutoff wheel to allow clearance for the main braces (Fig.I).

5. Enlarge the existing hole in both sides of the frame to 9/16" (Fig.J). Then, reinstall the bumper using one bolt on each side to temporarily hold it in place (Fig.K). *Note: Due to manufacturing frame variances, you may need to slot this hole slightly in order to properly install this baseplate.*

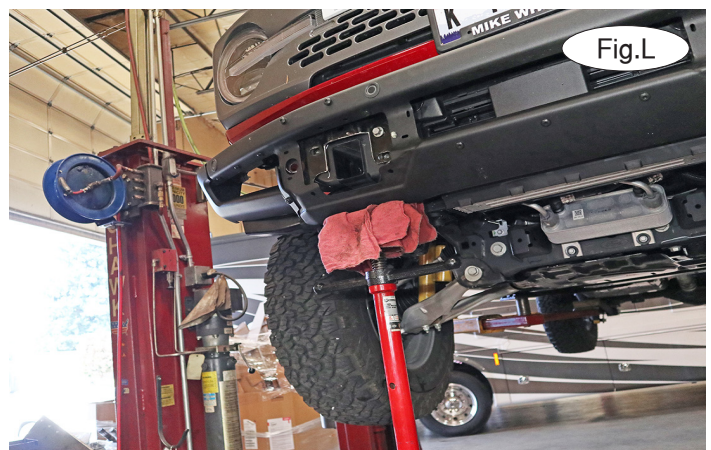
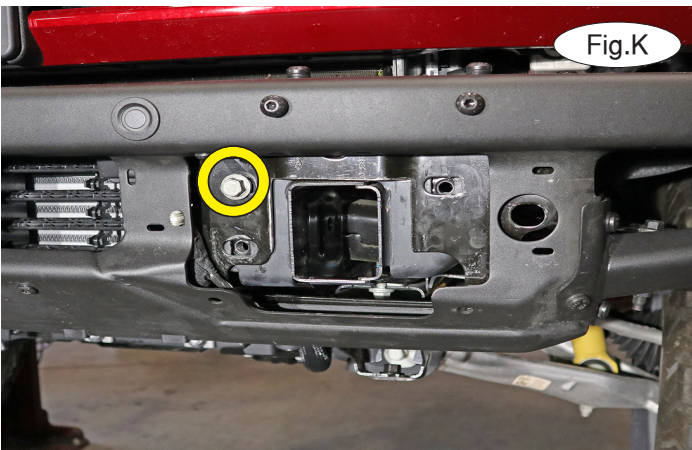

6. Use a jack stand or a second person to support the bumper on the passenger side of the vehicle (Fig.L). Remove the bolt you temporarily installed in step 5. Now, use the drawing on page one to locate the passenger side-specific main brace. Then, place Loctite on the three factory 15mm bolts that you removed in step 3 and place them through the main brace (Fig.M). Place a 13/16" tube spacer on the rear of each bolt and then bolt the assembly into the factory tow hook mount (Fig.N) and snug tight the factory bolts. Repeat this process for the driver's side.





BASEPLATE KIT INSTALLATION INSTRUCTIONS

KIT# 524469-4

08/16/23
KS

ROADMASTER, Inc. 6110 NE 127th Ave. Vancouver, WA 98682 360-896-0407 fax 360-735-9300 www.roadmasterinc.com

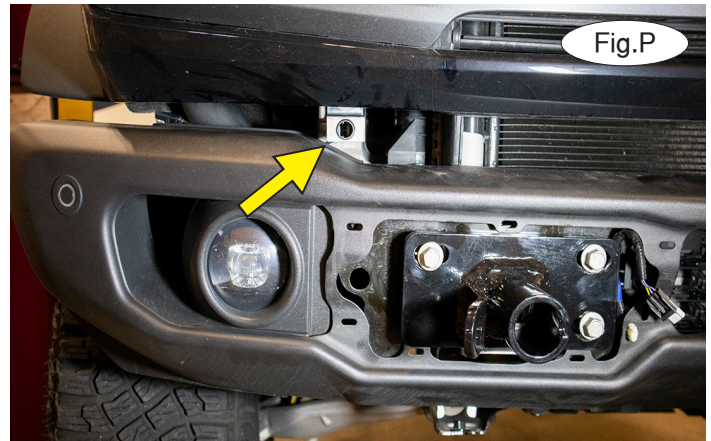
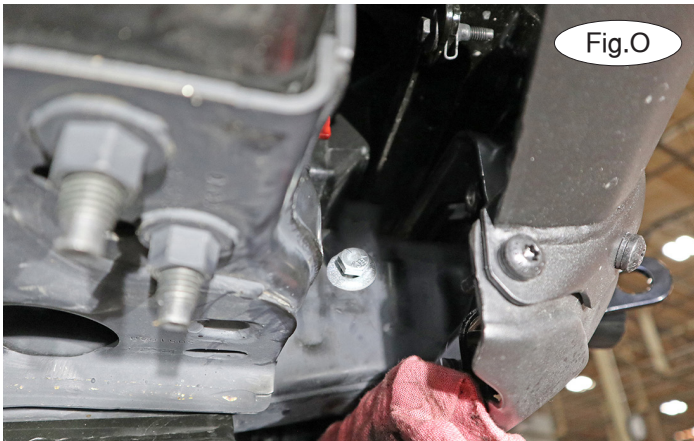

7. Then, on each side of the frame, use a $\frac{1}{2}$ " x $1\frac{1}{4}$ " bolt with $\frac{1}{2}$ " SAE washer, $\frac{1}{2}$ " lock washer and Loctite to bolt through the frame, baseplate and into the welded nut (Fig.O). Now, align your bumper left to right and up and down so you have even spacing on both sides and snug tight the bolts.

8. Tighten first the 15mm bolts and then the $1\frac{1}{4}$ " bolts to the bolt torque specifications found at the end of this document.

9. Reinstall the skid plate and tow hook covers by reversing steps 1 and 2.

10. Mount the breakaway in the location shown (Fig.P).

11. On each side, insert the removable front arm into the front receiver 90 degrees from its final towing position, depressing the spring-loaded pin against the receiver. Twist back 90 degrees until the spring-loaded pin snaps into place in the notch on the receiver, locking the arm into place in its final towing position. **Please note: It is the owner's responsibility to ensure the locking of the pins before towing. Otherwise, failure of the towing system will result.**

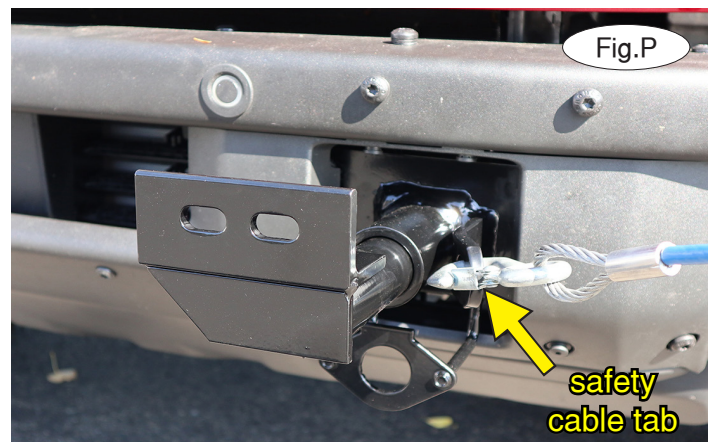

IMPORTANT!

Safety cables are required by law. When towing, connect safety cables to the safety cable tabs illustrated on the separate insert with the drawing and parts list and in Figure Q. Make certain there is adequate slack in the cables to allow a full turning radius; otherwise, damage will result. If necessary, longer cables or cable extensions are available.



BASEPLATE KIT INSTALLATION INSTRUCTIONS

KIT# 524469-4

08/16/23
KS

ROADMASTER, Inc. 6110 NE 127th Ave. Vancouver, WA 98682 360-896-0407 fax 360-735-9300 www.roadmasterinc.com

Three options for attaching the wiring plug to the main receiver brace

For six-wire plugs: Use the two supplied 3/4" self-tapping screws to attach the electrical plug directly to the rods on the front of the main receiver brace.

For four-wire round plugs: Attach to the plug mounting plate and then use the two supplied 3/4" self-tapping screws to attach the mounting plate to the rods on the front of the main receiver brace.

For four-wire flat plugs: Place the plug through the mounting plug plate, and then secure it using the supplied zip tie on the front of the plug (Fig.R). Use the two supplied 3/4" self-tapping screws to attach the mounting plate to the rods on the front of the main receiver brace.

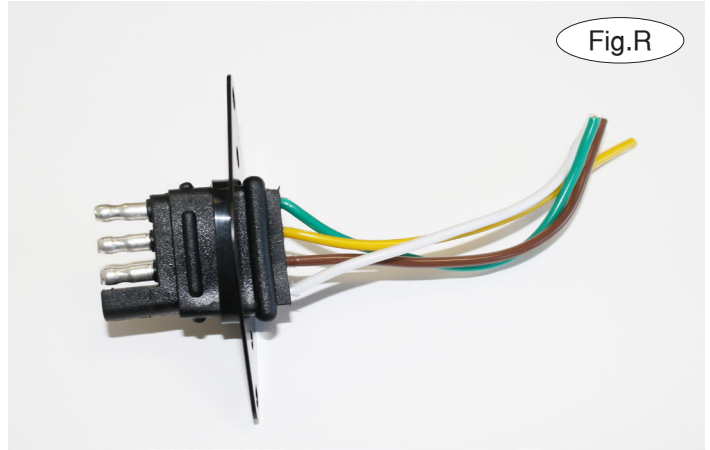

BOLT TORQUE REQUIREMENTS

Note: The torque values represented below are intended as general guidelines. Torque requirements for specific applications may vary. Roadmaster does not warrant this information to be accurate for all applications and disclaims all liability for any claims or damages which may result from its use.

STANDARD BOLTS

Thread Size	Grade	Torque
5/16-18	5	13 ft./lb.
3/8-16	5	23 ft./lb.
7/16-14	5	37 ft./lb.
1/2-13	5	57 ft./lb.
5/8-11	5	112 ft./lb.

METRIC BOLTS

Thread Size	Grade	Torque
6mm-1.0	8.8	6 ft./lb.
8mm-1.0	8.8	18 ft./lb.
8mm-1.25	8.8	16 ft./lb.
10mm-1.25	8.8	36 ft./lb.
10mm-1.5	8.8	31 ft./lb.

METRIC BOLTS

Thread Size	Grade	Torque
12mm-1.25	8.8	64 ft./lb.
12mm-1.5	8.8	60 ft./lb.
12mm-1.75	8.8	55 ft./lb.
14mm-2.0	8.8	88 ft./lb.