



BASEPLATE KIT INSTALLATION INSTRUCTIONS

KIT# 524472-5

12/07/23
KS

ROADMASTER, Inc. 6110 NE 127th Ave. Vancouver, WA 98682 360-896-0407 fax 360-735-9300 www.roadmasterinc.com

Second person to assist
Ratchets
7, 8, 10, 13 and 15mm sockets
3/4" and 3/8" sockets
11mm, 3/8", 3/4" wrenches
T30 driver

What You'll Need

Drill
Panel tool
Small flathead
screwdriver

2 1/4" hole saw
Reciprocating saw
Permanent or paint marker
Tape measure
Torque wrench
Loctite© Blue or Red

*Important
Note: This baseplate will not
accommodate the Guardian
rock shield, some models of the
Tow Defender, or the StowMas-
ter and StowMaster All Terrain
tow bars.*

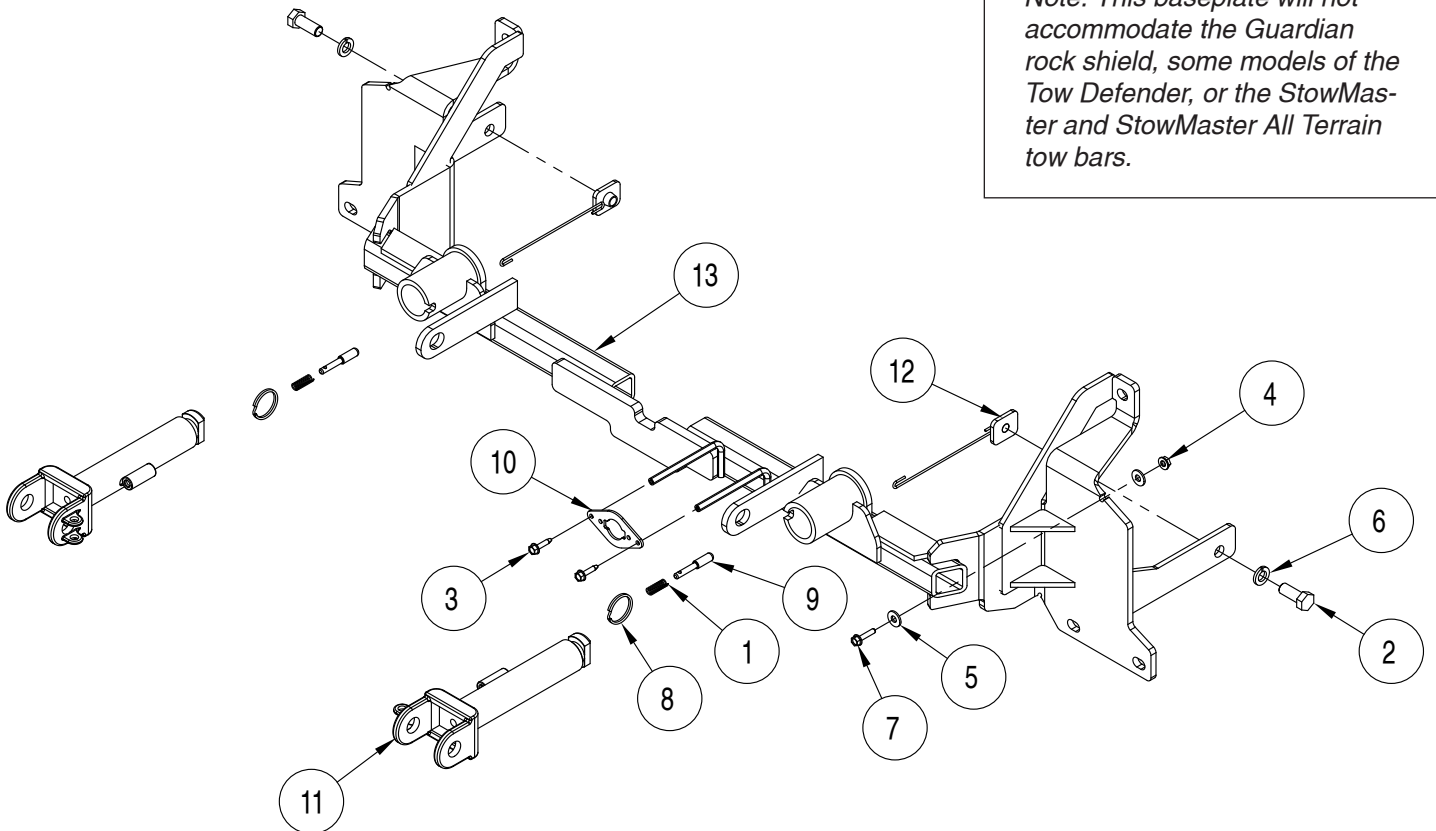

ITEM	QTY	DESCRIPTION	PART NUMBER
1	2	SPRING	200146-00
2	2	1/2" x 1 1/4" BOLT	350094-00
3	2	#10 x 3/4" SELF DRILLING SCREW	350247-35
4	1	1/4" WHIZ NUT	350251-20
5	2	1/4" FLAT WASHER	350300-00
6	2	1/2" LOCK WASHER	350309-00
7	1	1/4" x 1" WHIZ BOLT	350400-20
8	2	RING	350520-00
9	2	LOCK PIN	A000008
10	1	WIRE PLUG PLATE	A003801
11	2	ARM	C002383
12	2	1 1/4" x 1 1/2" THREADED BACKING PLATE W/ 6" ROD	C002077
13	1	MAIN RECEIVER	C003681
14	2	ZIP TIE	300140-8



BASEPLATE KIT INSTALLATION INSTRUCTIONS

KIT# 524472-5

12/07/23
KS

ROADMASTER, Inc. 6110 NE 127th Ave. Vancouver, WA 98682 360-896-0407 fax 360-735-9300 www.roadmasterinc.com

This is one of our direct-connect series, which allows the visible front portion of the baseplate to be easily removed from the front of the vehicle (Fig.A and Fig.B). This kit consists of two side braces, a crossbar, two removable front braces, and a hardware pack.

The braces mount to the frame and the crossbar. The removable front braces install in the main receiver brace.

Before starting the installation, lay out the kit components in order, as they will be used. This will give you a visual idea of how the components work, and will also confirm that everything is present and accounted for.



IMPORTANT: All baseplates **must** be assembled with all the bolts left loose for final adjustment and positioning (before tightening) unless otherwise instructed. All bolts **must** be torqued for proper strength. If more than one bolt is used per fastening point, the diagram may only show one. Use flat washers over all slotted holes and lock washers on all fasteners.

WARNING

Failure to heed these warnings or follow the installation instructions may result in a voided warranty, loss of towed vehicle, personal injury or death.

- Do not weld or modify this baseplate or its components. Welding or modification will void the warranty.
- Do not use this document as a basis to design/fabricate a baseplate, as it may not show all parts or structural components.
- We strongly recommend professional installation.
- If the towed vehicle has been in an accident, it must be properly repaired before attaching the baseplate. Do not install the baseplate if any structural frame damage is found.
- The installer must use all bolts and parts supplied. If running changes were made by the vehicle manufacturer after this kit was designed, some bolts or other fasteners may no longer be the correct size. It is the installer's responsibility to verify this kit is securely fastened to the vehicle.
- Use Loctite® Red on all bolts used to secure this baseplate. Torque all bolts to the specifications found at the end of these instructions. Do not over-torque the bolts or failure may occur.
- The installer must inspect the baseplate to ensure adequate clearance, particularly around hoses, air conditioner lines, radiators, etc. or non-warranty failure may result.
- Roadmaster manufactures many styles of baseplates. If your baseplate has removable arms, they must be removed before driving the vehicle, unless the arms can be pinned or padlocked in place. If not secured, the arms could vibrate out.
- Some motorhome chassis have such a tight turning radius that you can damage your motorhome, towed vehicle, tow bar or baseplate while turning sharply. Before getting on the road, test your turning radius in an empty parking lot. Turning too sharply could

result in non-warranty damage to your towing system, motorhome and/or towed vehicle.

- Do not back up with the towed vehicle attached or non-warranty damage will occur to your towing system or vehicles.
- The safety cables must connect the towing vehicle to the towed vehicle frame to frame, with the cables crossed, with enough slack for sharp turns. See cable instructions for proper routing. Failure to do so will result in non-warranty damage and/or the loss of the towed vehicle.
- This kit is designed for use with ROADMASTER tow bars and ROADMASTER adapters only. Using this kit with other brands, without an approved ROADMASTER adapter, may result in non-warranty damage or injury.
- Receiver extensions and out-of-level towing situations of 3 inches or more. This can cause the system to swing much higher and lower, causing excessive strain on the tow bar, baseplate and frame. That can cause the towing system to fail, causing property damage, personal injury or even death. If you must use a receiver extension or drop hitch to tow, it will reduce your receiver's weight capacity by 1/3 to avoid damaging your system. Never use more than one extension and/or drop hitch, as this will void your warranty.
- Every 3,000 miles, the owner must inspect all mounting points for cracks or fatigue, and check the fasteners for proper torque, according to the bolt torque requirements chart on the last page of these instructions.
- The owner must follow the vehicle manufacturer's instructions to prepare the vehicle for towing. Failure to do so may cause severe damage to the vehicle.
- This baseplate is only warranted for the original installation. Installing a used baseplate on another vehicle is not recommended and will void the warranty.



BASEPLATE KIT INSTALLATION INSTRUCTIONS

KIT# 524472-5

12/07/23
KS

ROADMASTER, Inc. 6110 NE 127th Ave. Vancouver, WA 98682 360-896-0407 fax 360-735-9300 www.roadmasterinc.com

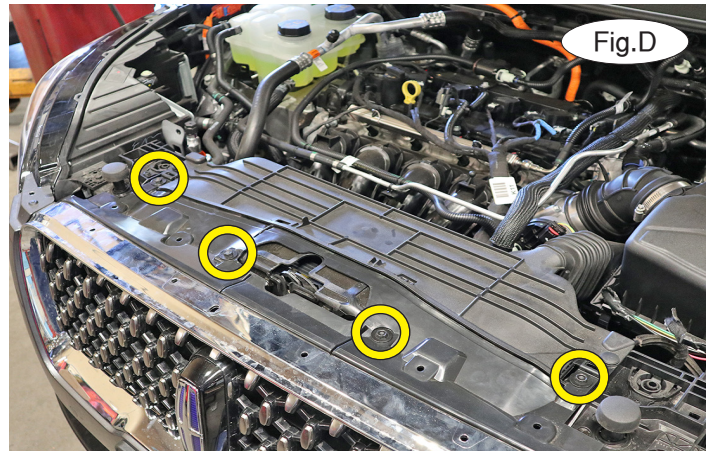
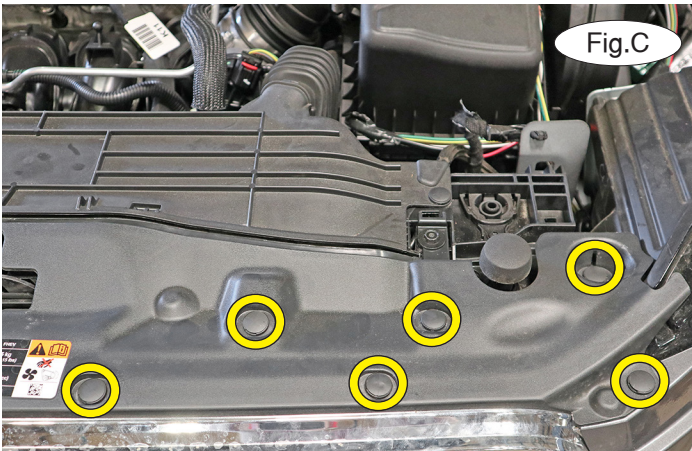

Important: please use all supplied bolts and parts and read all instructions carefully before beginning this installation. The majority of questions you may have can be answered within the text, and proper installation will ensure safe and secure travel.

1. On each side, remove six plastic fasteners attaching the radiator cover to the core support (Fig.C).
2. Remove four 10mm bolts attaching the top of the fascia to the radiator housing (Fig.D).
3. On each side, remove seven plastic fasteners attaching the fender well and fender trim to the fascia (Fig.E).

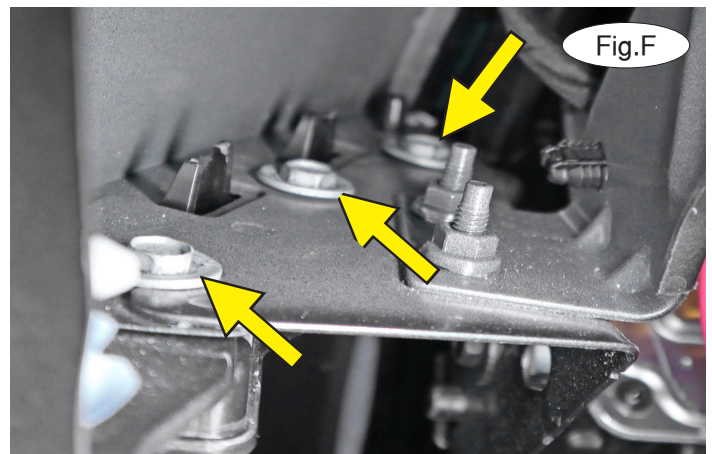

4. On each side, pull down the fender liner and remove three 10mm bolts attaching the fascia to the fender (Fig.F).
 5. On each side, peel back the fender trim about halfway and use a soft rag to prop it away from the vehicle (Fig.G). Then, on the passenger side only, disconnect the large wiring harness, the washer fluid line and front camera line (Fig.H).
- IMPORTANT! Under no circumstances should you unplug any of the orange-taped, high voltage harnesses.**





BASEPLATE KIT INSTALLATION INSTRUCTIONS

KIT# 524472-5

12/07/23
KS

ROADMASTER, Inc. 6110 NE 127th Ave. Vancouver, WA 98682 360-896-0407 fax 360-735-9300 www.roadmasterinc.com

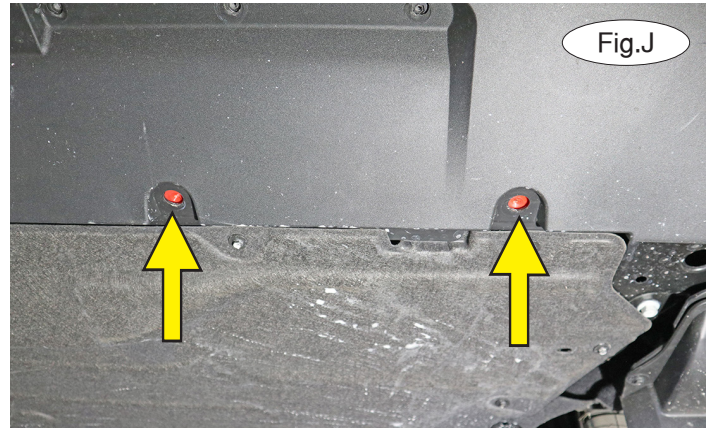
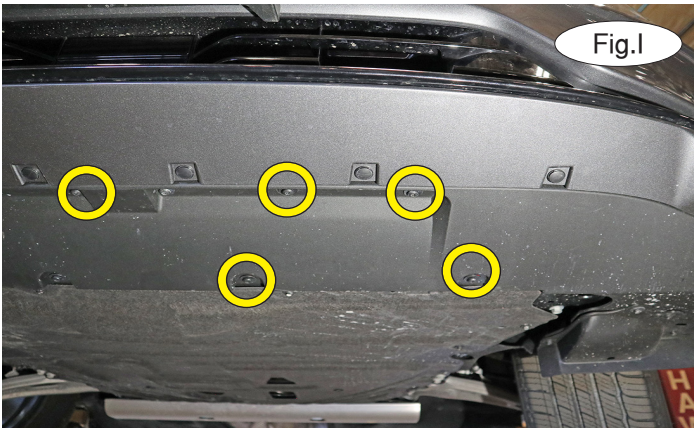

6. On each side, remove five T30 torx screws attaching the lower splash shield to the subframe (Fig.I). Then, remove two 7mm bolts attaching the splash shield to the fascia (Fig.J).

7. On each side, apply downward pressure to the fascia to open the seam and then very carefully use a small flathead screwdriver to release the clips (Fig.K) and then pull down to release the fascia at the seam (Fig.L). Then, push forward on the fascia and release the retaining clip over the radiator (Fig.M). Set the fascia aside for now.



8. On each side, remove one plastic fastener attaching the air deflector to the radiator housing (Fig.N). Around the deflector, release eight clips as shown (Fig.O – next page) and set the housing aside. It will not be replaced.



All illustrations and specifications contained herein are based on the latest information available at the time of publication approval. ROADMASTER, INC. reserves the right to make changes at any time without notice in material, specification and models or to discontinue models.



BASEPLATE KIT INSTALLATION INSTRUCTIONS

KIT# 524472-5

12/07/23
KS

ROADMASTER, Inc. 6110 NE 127th Ave. Vancouver, WA 98682 360-896-0407 fax 360-735-9300 www.roadmasterinc.com

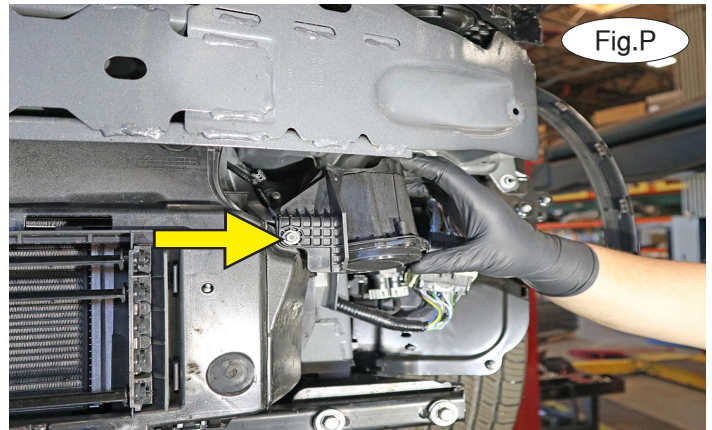

9. On the driver's side only, remove one 8mm screw attaching the Pedestrian Alert Device. Pull outward to release the retaining clip. Unplug the sensor and set it aside for now (Fig.N). Then, unclip the PAD harness from behind the radiator housing to extend its length for a future step (Fig.O). Now, trim off part of the shutter housing as shown (Fig.P).

10. On the passenger side only, push in on the two bottom wiring harness clips to push them into the shutter housing. Then, very carefully trim off a piece of the shutter housing as shown (Fig.Q) to allow clearance for the main receiver.

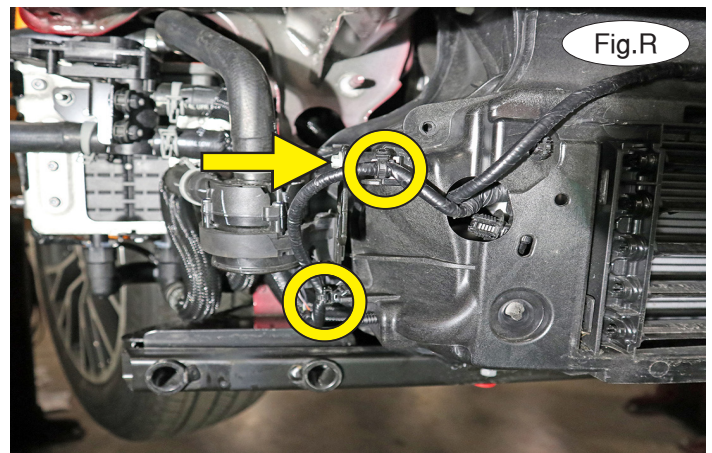
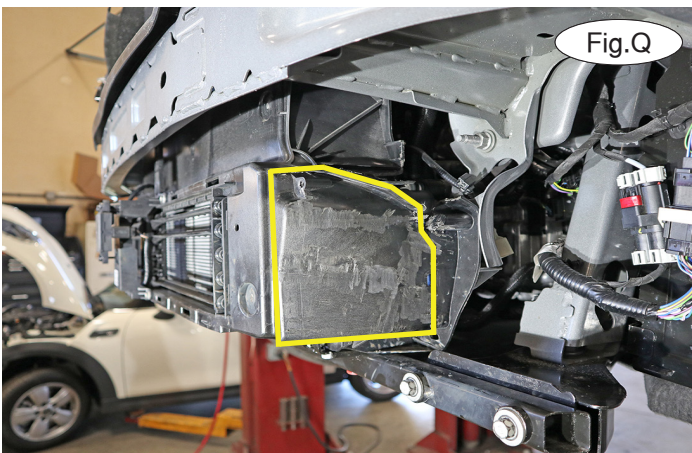

11. Unplug the air switch pump and unclip the harness from the shutter housing (Fig.R – circles). Then, remove one 8mm screw (Fig.R – arrow) attaching the air pump to the shutter housing and pull out to release it. Let it hang down for now.

12. On the driver's side only, remove one 10mm nut attaching the computer box to the frame (Fig.S) and then push rearward to temporarily move it out of the way.

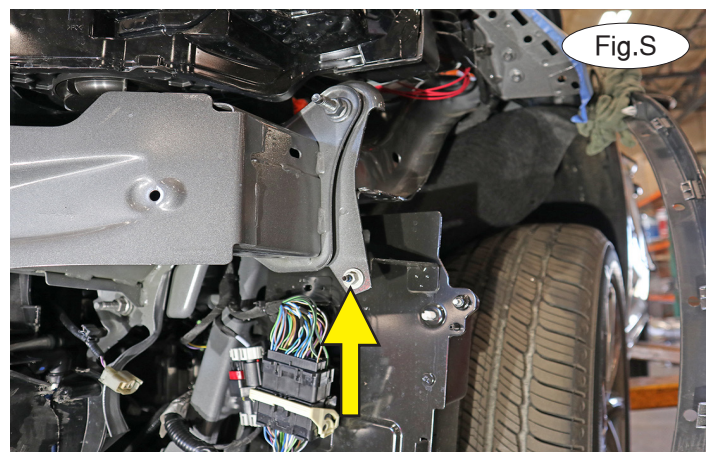



BASEPLATE KIT INSTALLATION INSTRUCTIONS

KIT# 524472-5

12/07/23
KS

ROADMASTER, Inc. 6110 NE 127th Ave. Vancouver, WA 98682 360-896-0407 fax 360-735-9300 www.roadmasterinc.com

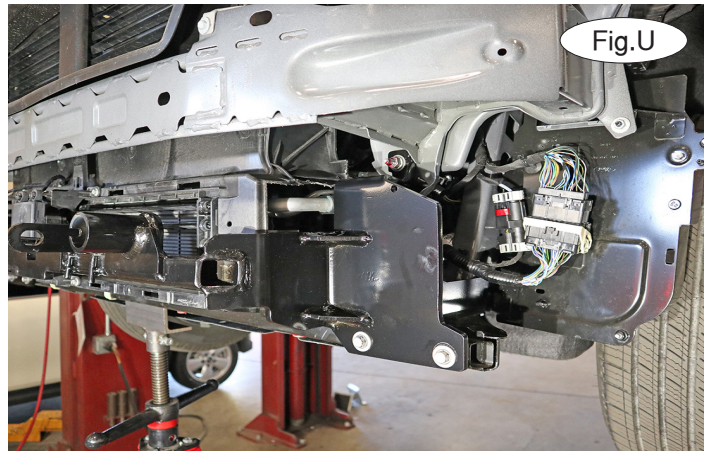
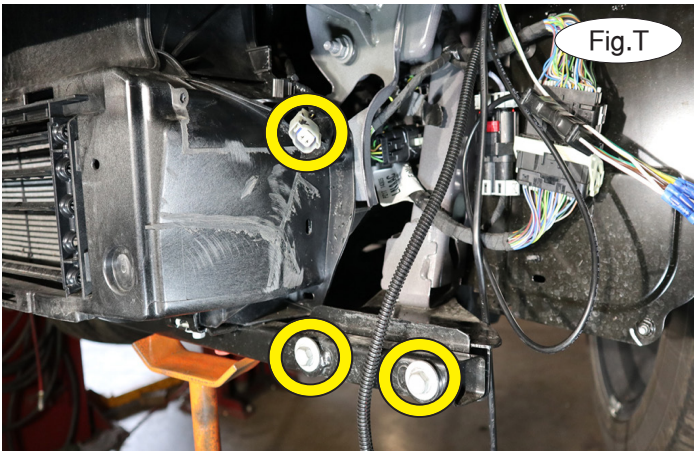

13. On each side, remove two 13mm bolts and one 15mm nut attaching the lower radiator support to the subframe (Fig.T).

14. Use a floor jack to support the subframe. Place the main receiver brace over the mounts you exposed in step 13 and replace the 15mm nuts and 13mm bolts (Fig.U). *Note: Use Loctite on the nut and bolts and torque them. Note: If the vehicle is so equipped, ensure that the lower mount of the ACC sensor is nested into the cutout on the baseplate. Under no circumstances should it be touching the baseplate (Fig.V).*

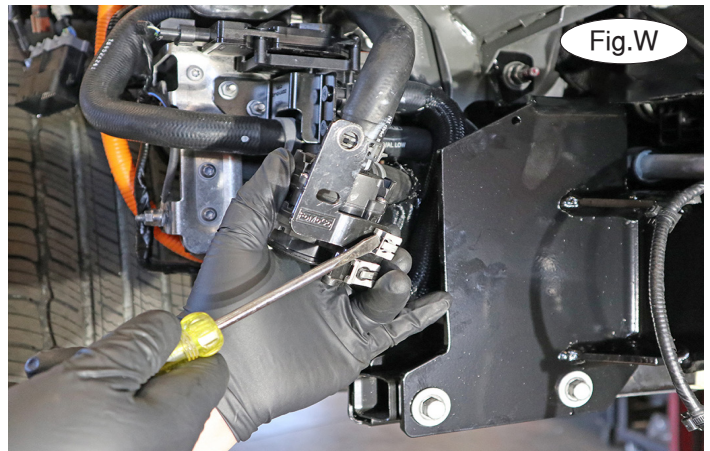
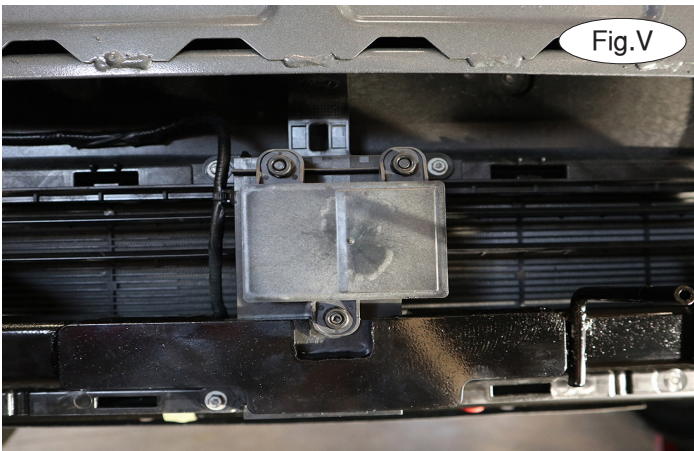

15. On the passenger side only, remove two retainer clips from the air pump mounting bracket (Fig.W). Use the two supplied zip ties to secure the bracket out of the way.

16. On the driver's side only, trim off the gusset on the back of the PAD mount, using the yellow line in Figure X as a guide. Then, reattach the PAD harnesses and mount the unit to the provided hole on the baseplate using the supplied 1/4" x 1" whiz bolt and 1/4" nut (Fig.Y – next page).





BASEPLATE KIT INSTALLATION INSTRUCTIONS

KIT# 524472-5

12/07/23
KS

ROADMASTER, Inc. 6110 NE 127th Ave. Vancouver, WA 98682 360-896-0407 fax 360-735-9300 www.roadmasterinc.com

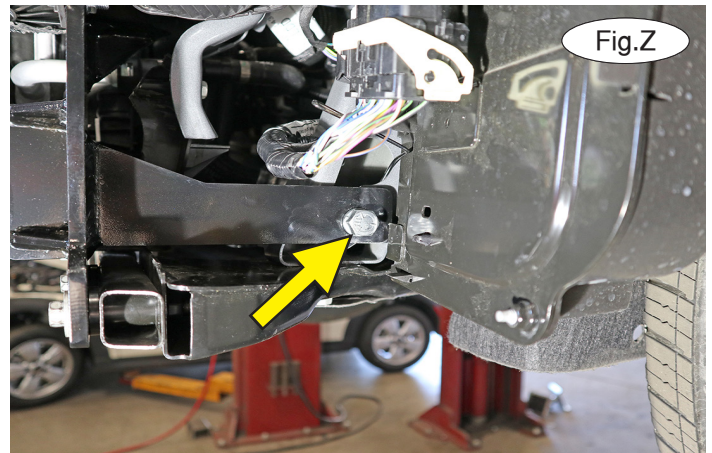

17. Prepare two $\frac{1}{2}$ " x $\frac{1}{4}$ " bolts with $\frac{1}{2}$ " lock washers and Loctite. Then, locate the two $\frac{3}{16}$ " x $\frac{1}{4}$ " x $\frac{1}{2}$ " threaded backing plates. On each side, place one of the plates up into the frame member behind the rear mounting hole of the brace (Fig.Z). Then, bolt through the brace and into the backing plate and tighten the bolt to the bolt torque requirements found at the end of these instructions (Fig.AA). Bend the rod backward, or snap it off with pliers.

18. Remount the computer box by bending it back into place and then replacing the 10mm nut.

19. If you are using a Brakeaway switch, pre-drill into the crossbar using a $\frac{3}{16}$ " drill bit. Then, bend the Brakeaway switch mounting tab 90 degrees and attach it to the front of the crossbar using the supplied self-tapping screw as shown in Figure BB.

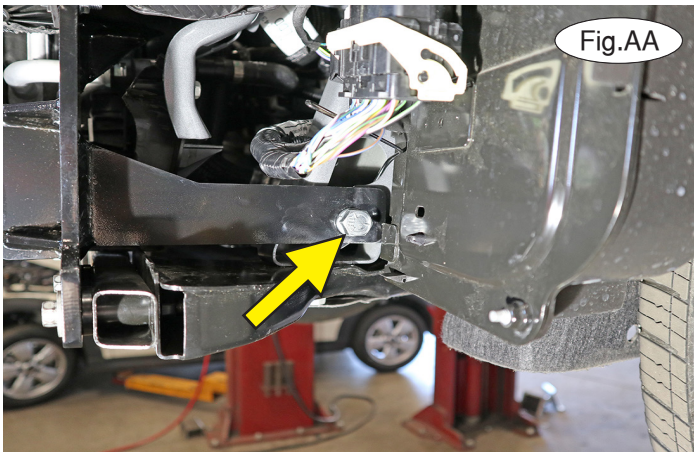

20. Hold the fascia up to the main receiver brace and note areas that will need to be trimmed. On each side, on the back side of the fascia, trim the inside foglight mount flush to the bolts to allow clearance for the main receiver brace. The yellow lines in Figure CC denote the section being trimmed off (Fig.CC – before trimming, and Fig.CC, inset – after trimming). *Note: Use caution, as trimming too much could cause the mount to break.*

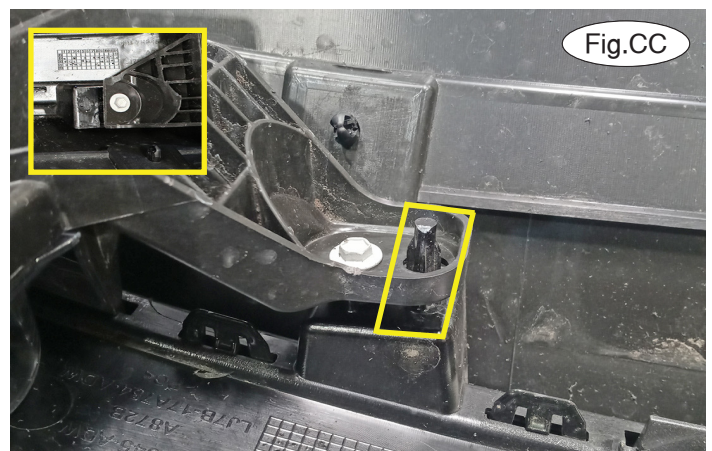



BASEPLATE KIT INSTALLATION INSTRUCTIONS

KIT# 524472-5

12/07/23
KS

ROADMASTER, Inc. 6110 NE 127th Ave. Vancouver, WA 98682 360-896-0407 fax 360-735-9300 www.roadmasterinc.com

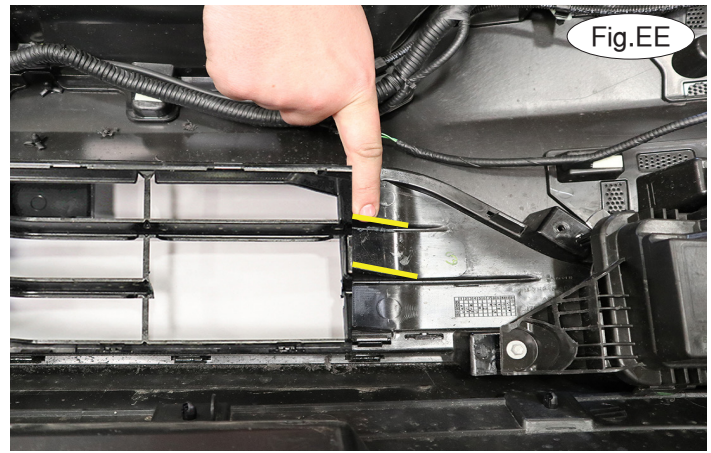
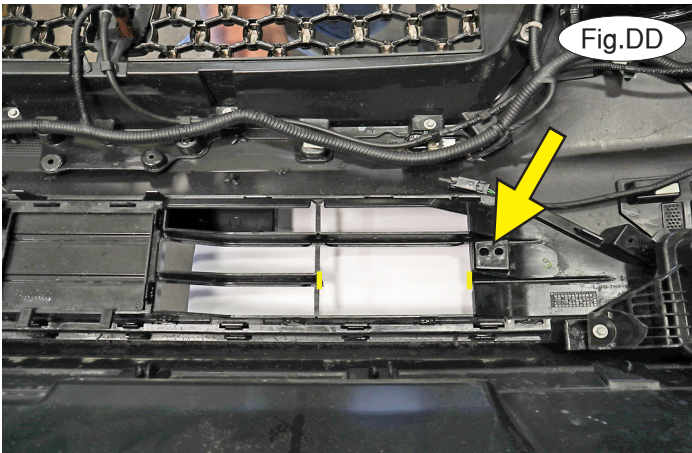

21. On each side, trim the back of the fascia as shown (Fig.DD – yellow lines). Completely trim off the piece indicated (Fig.DD – yellow arrow). *Note:* Additional trimming may be needed on the fins to allow clearance for the main receiver brace (Fig.EE – yellow lines).

22. Zip tie the ambient temperature sensor to the back of the fascia (Fig.FF).

23. Reinstall the fascia, reversing steps 1 through 7.

24. On each side, insert the removable front arm into the front receiver 90 degrees from its final towing position, depressing the spring-loaded pin against the receiver. Twist back 90 degrees until the spring-loaded pin snaps into place in the notch on the receiver, locking the arm into place in its final towing position. ***Please note: It is the owner's responsibility to ensure the locking of the pins before towing. Otherwise, failure of the towing system will result.***

25. Install the tow bar to the baseplate, according to the manufacturer's instructions.

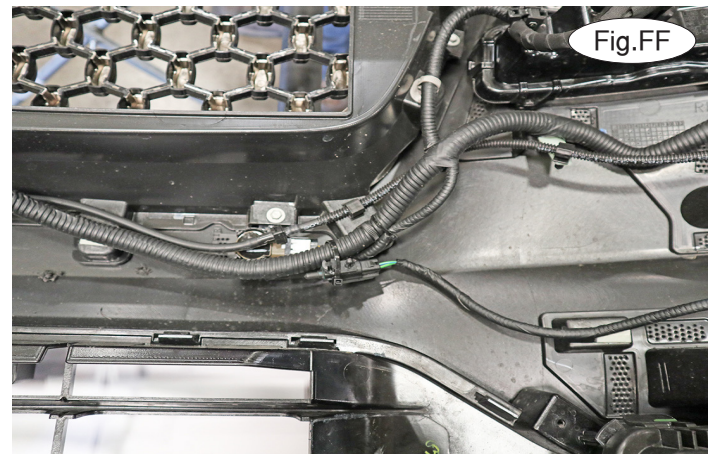

IMPORTANT!

Safety cables are required by law. When towing, connect safety cables to the safety cable tabs illustrated on the first page and in Figure GG. Make certain there is adequate slack in the cables to allow a full turning radius; otherwise, damage will result. If necessary, longer cables or cable extensions are available.



BASEPLATE KIT INSTALLATION INSTRUCTIONS

KIT# 524472-5

12/07/23
KS

ROADMASTER, Inc. 6110 NE 127th Ave. Vancouver, WA 98682 360-896-0407 fax 360-735-9300 www.roadmasterinc.com

Three options for attaching the wiring plug to the main receiver brace

For six-wire plugs: use the two supplied 3/4" self-tapping screws to attach the electrical plug directly to the rods on the front of the main receiver brace.

For four-wire round plugs: attach to the plug mounting plate and then use the two supplied 3/4" self-tapping screws to attach the mounting plate to the rods on the front of the main receiver brace.

For four-wire flat plugs: place the plug through the mounting plug plate, and then secure it using the supplied zip tie on the front of the plug (Fig.GG). Use the two supplied 3/4" self-tapping screws to attach the mounting plate to the rods on the front of the main receiver brace.

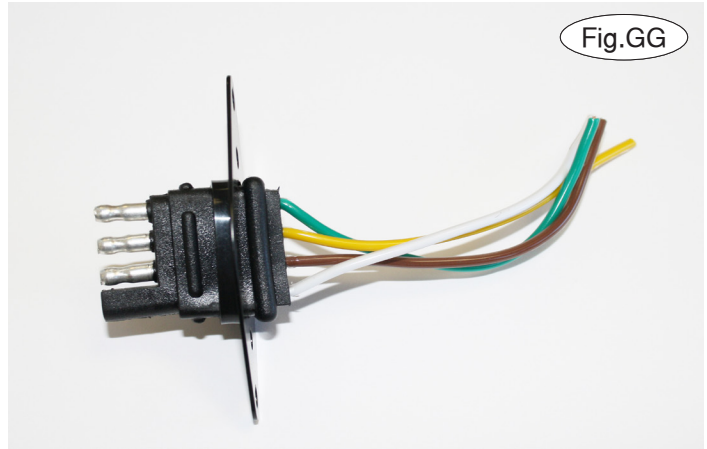

Fig.GG

BOLT TORQUE REQUIREMENTS

Note: The torque values represented below are intended as general guidelines. Torque requirements for specific applications may vary. Roadmaster does not warrant this information to be accurate for all applications and disclaims all liability for any claims or damages which may result from its use.

STANDARD BOLTS

Thread Size	Grade	Torque
5/16.....	5.....	13 ft./lb.
3/8.....	5.....	23 ft./lb.
7/16.....	5.....	37 ft./lb.
1/2.....	5.....	56 ft./lb.
5/8.....	5.....	150 ft./lb.

METRIC BOLTS

Thread Size	Grade	Plated / Unplated
8mm-1.0	8.8	20 ft./lb. 18 ft./lb.
8mm-1.25	8.8	19 ft./lb. 18 ft./lb.
10mm-1.25	8.8	38 ft./lb. 36 ft./lb.
10mm-1.5	8.8	37 ft./lb. 35 ft./lb.

METRIC BOLTS

Thread Size	Grade	Plated / Unplated
12mm-1.25	8.8	70 ft./lb. 65 ft./lb.
12mm-1.5	8.8	66 ft./lb. 61 ft./lb.
12mm-1.75	8.8	65 ft./lb. 60 ft./lb.
14mm-2.0	8.8	104 ft./lb. 97 ft./lb.

All illustrations and specifications contained herein are based on the latest information available at the time of publication approval. ROADMASTER, INC. reserves the right to make changes at any time without notice in material, specification and models or to discontinue models.