



BASEPLATE KIT INSTALLATION INSTRUCTIONS

KIT# 524477-5

06/2024
RS

ROADMASTER, Inc. 6110 NE 127th Ave. Vancouver, WA 98682 360-896-0407 fax 360-735-9300 www.RoadmasterInc.com

Second person to assist
T30 Torx driver
3/8" and 3/4" sockets
7, 8, 10, 13, 15 & 21mm
sockets

What You'll Need

Ratchets
17/32" bit and drill
Adjustable wrench
Permanent marker
Panel tool

Tape measure
Reciprocating saw
Torque wrench
Loctite© Red or Blue

Need Help? Call Toll-Free
 1-800-669-9690

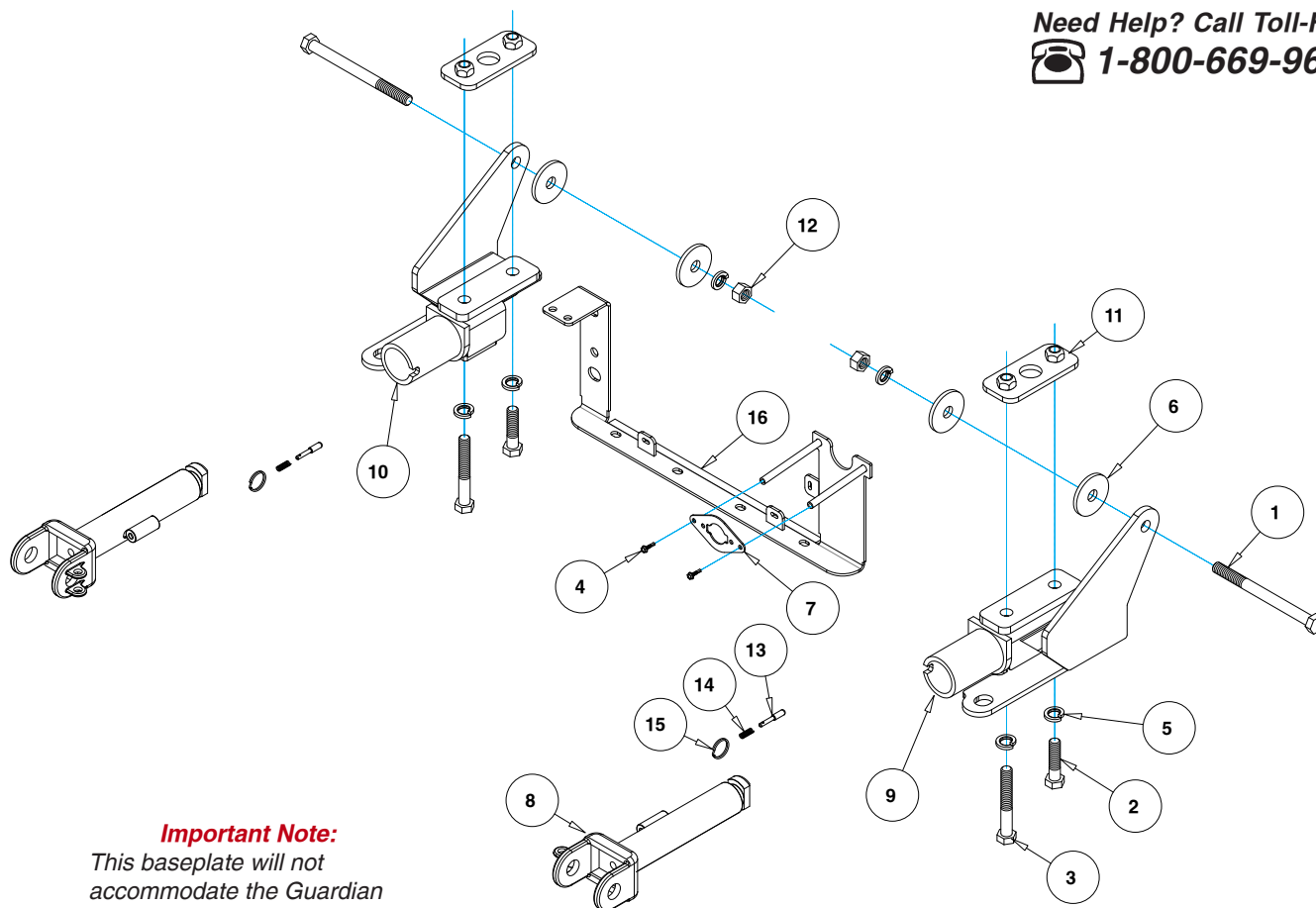

Important Note:

This baseplate will not accommodate the Guardian rock shield, some models of the Tow Defender, or StowMaster tow bars.

ITEM	QTY	NAME	PART #
1	2	1/2" x 6" BOLT	350109-00
2	2	1/2" x 2" GRADE 8 BOLT	350258-80
3	2	1/2" x 4" GRADE 8 BOLT	350258-90
4	2	#10 x 3/4" SELF DRILLING SCREW	350246-35
5	6	1/2" LOCK WASHER	350309-00
6	4	1/2" PLATE WASHER	A003086
7	1	WIRE PLUG PLATE	A003801
8	2	ARM	C002383
9	1	DRIVER SIDE RECEIVER	C003081
10	1	PASSENGER SIDE RECEIVER	C003082
11	2	THREADED BACKING PLATE	C003476
12	2	1/2" HEX NUT	350258-00
13	2	LOCK PIN	A000008
14	2	SPRING	200146-00
15	2	RING	350520-00
16	1	BRACKET	C003811



BASEPLATE KIT INSTALLATION INSTRUCTIONS

KIT# 524477-5

06/2024
RS

ROADMASTER, Inc. 6110 NE 127th Ave. Vancouver, WA 98682 360-896-0407 fax 360-735-9300 www.RoadmasterInc.com

IMPORTANT: All baseplates **must** be assembled with all the bolts left loose for final adjustment and positioning (before tightening) unless otherwise instructed. All bolts **must** be torqued for proper strength. If more than one bolt is used per fastening point, the diagram may only show one. Use flat washers over all slotted holes and lock washers on all fasteners.

WARNING

Failure to heed these warnings or follow the installation instructions may result in a voided warranty, loss of towed vehicle, personal injury or death.

- Do not weld or modify this baseplate or its components. Welding or modification will void the warranty.
- Do not use this document as a basis to design/fabricate a baseplate, as it may not show all parts or structural components.
- We strongly recommend professional installation.
- If the towed vehicle has been in an accident, it must be properly repaired before attaching the baseplate. Do not install the baseplate if any structural frame damage is found.
- The installer must use all bolts and parts supplied. If running changes were made by the vehicle manufacturer after this kit was designed, some bolts or other fasteners may no longer be the correct size. It is the installer's responsibility to verify this kit is securely fastened to the vehicle.
- Use Loctite® Red on all bolts used to secure this baseplate. Torque all bolts to the specifications found at the end of these instructions. Do not over-torque the bolts or failure may occur.
- The installer must inspect the baseplate to ensure adequate clearance, particularly around hoses, air conditioner lines, radiators, etc. or non-warranty failure may result.
- Roadmaster manufactures many styles of baseplates. If your baseplate has removable arms, they must be removed before driving the vehicle, unless the arms can be pinned or padlocked in place. If not secured, the arms could vibrate out.
- Some motorhome chassis have such a tight turning radius that you can damage your motorhome, towed vehicle, tow bar or baseplate while turning sharply. Before getting on the road, test your turning radius in an empty parking lot. Turning too sharply could result in non-warranty damage to your towing system, motorhome and/or towed vehicle.
- Do not back up with the towed vehicle attached or non-warranty damage will occur to your towing system or vehicles.
- The safety cables must connect the towing vehicle to the towed vehicle frame to frame, with the cables crossed, with enough slack for sharp turns. See cable instructions for proper routing. Failure to do so will result in non-warranty damage and/or the loss of the towed vehicle.
- This kit is designed for use with ROADMASTER tow bars and ROADMASTER adapters only. Using this kit with other brands, without an approved ROADMASTER adapter, may result in non-warranty damage or injury.
- Receiver extensions and out-of-level towing situations of 3 inches or more. This can cause the system to swing much higher and lower, causing excessive strain on the tow bar, baseplate and frame. That can cause the towing system to fail, causing property damage, personal injury or even death. If you must use a receiver extension or drop hitch to tow, it will reduce your receiver's weight capacity by 1/3 to avoid damaging your system. Never use more than one extension and/or drop hitch, as this will void your warranty.
- Every 3,000 miles, the owner must inspect all mounting points for cracks or fatigue, and check the fasteners for proper torque, according to the bolt torque requirements chart on the last page of these instructions.
- The owner must follow the vehicle manufacturer's instructions to prepare the vehicle for towing. Failure to do so may cause severe damage to the vehicle.
- This baseplate is only warranted for the original installation. Installing a used baseplate on another vehicle is not recommended and will void the warranty.

About this kit:

This is one of our direct connect-style series, which allows the visible front portion of the baseplate to be easily removed from the front of the vehicle (Fig.A and Fig.B).

This kit consists of a main receiver brace, two rear support braces, two removable front braces, and a hardware pack.

The main receiver brace mounts to the frame and side braces on each side. The removable front braces install in the main receiver braces.

Before starting the installation, lay out the kit components in order, as they will be used. This will give you a visual idea of how the components work, and will also confirm that everything is present and accounted for.





BASEPLATE KIT INSTALLATION INSTRUCTIONS

KIT# 524477-5

06/2024
RS

ROADMASTER, Inc. 6110 NE 127th Ave. Vancouver, WA 98682 360-896-0407 fax 360-735-9300 www.RoadmasterInc.com

Important: Please use all supplied hardware and read through these instructions carefully before beginning this installation. The majority of questions you may have can be answered within the text, and proper installation will ensure safe and secure travel.

1. On the passenger side, unclip seven plastic fasteners then, on the driver side, unclip eight plastic fasteners and two attached to the air intake box, that are attaching the filler panel to the core support and sub-frame. Depending upon the trim level of the vehicle, electrical and fluid connections may need to be disconnected in order to remove the grille. Remove and set aside the panel. (Fig.C, Insets, Fig.D Inset).

2. On each side, remove two 10mm bolts attaching the top of the grille to the core support (Fig.D).

3. Using another person, on each side, remove two 7mm screws attaching the body-colored filler panel to the wheel arch. Pull it out on each side, away from the wheel arch, and set it aside for now (Fig.E and Inset).

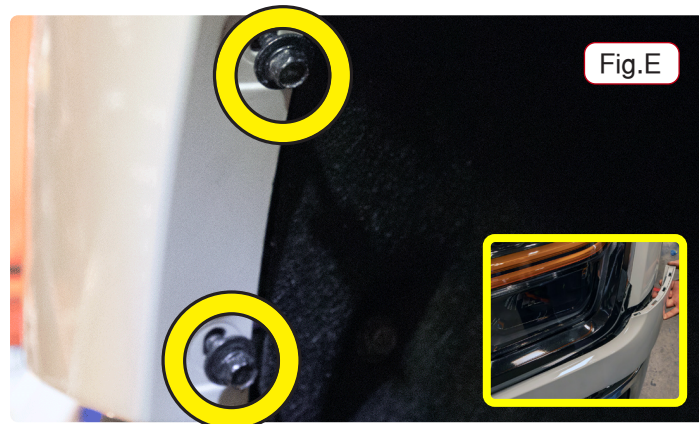
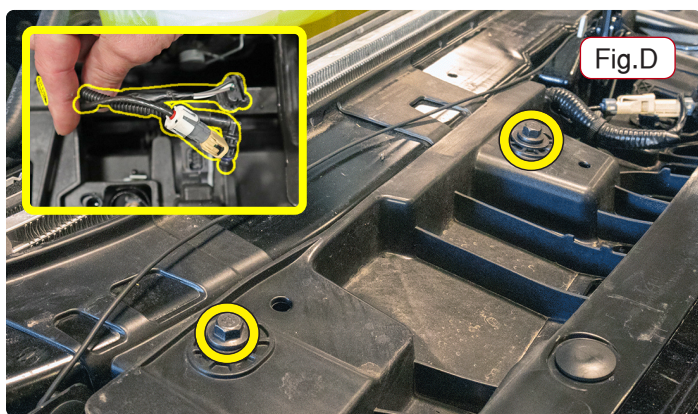
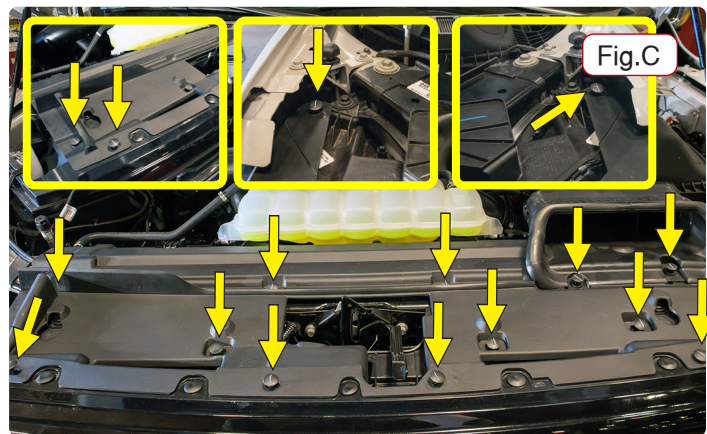

4. On each side, remove one 10mm bolt from the lower grille from the core support. Pull up and out to then remove the grille, set aside (Fig.F and Inset).

5. Disconnect any wiring harness, inner wiring harness on the passenger side, and cable further in the compartment. Then unclip three wiring mounts attached to the lower shutter housing, which may vary based upon trim level (Fig.G).

6. On each side, remove three 21mm nuts holding the bumper to the sub-frame, saving hardware for future step. With the help of a second person, pull straight out to remove the bumper (Fig.H).

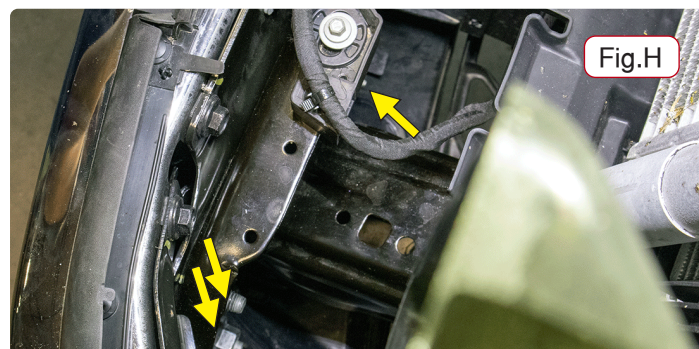
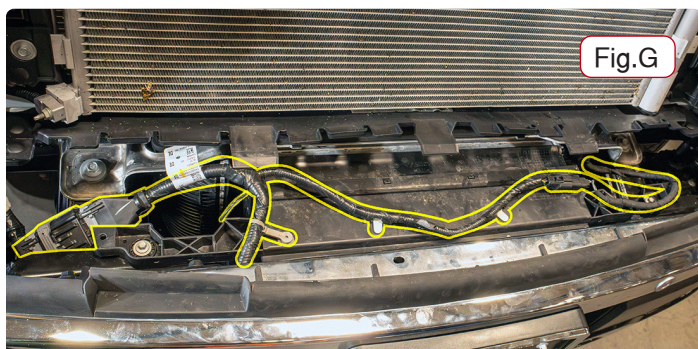
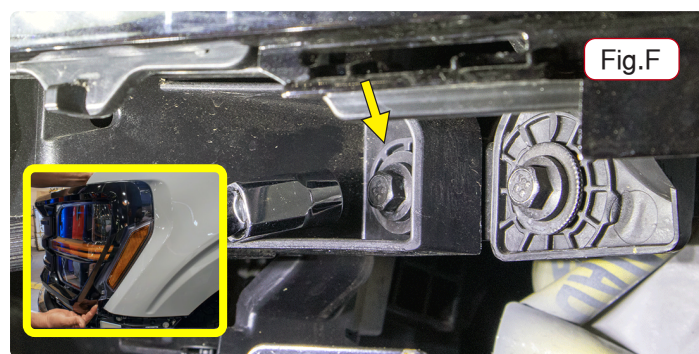



BASEPLATE KIT INSTALLATION INSTRUCTIONS

KIT# 524477-5

06/2024
RS

ROADMASTER, Inc. 6110 NE 127th Ave. Vancouver, WA 98682 360-896-0407 fax 360-735-9300 www.RoadmasterInc.com

7. On each side, pull straight out to remove the tow hook cover (Fig.I).

8. Working on the passenger side only, use a 15mm socket to remove the two bolts attaching the tow hook to the frame and the factory nutted backing plate. They will not be replaced. Retain the tow hook and its hardware for replacement in case the baseplate is ever removed from the vehicle (Fig.J).

9. On each side, place one of the supplied nutted backing plates inside the frame, over the two holes exposed in the previous step. Do steps 9, 10, 11, and 12 in sequence on the driver's side then repeat on the passenger's side (Fig.K).

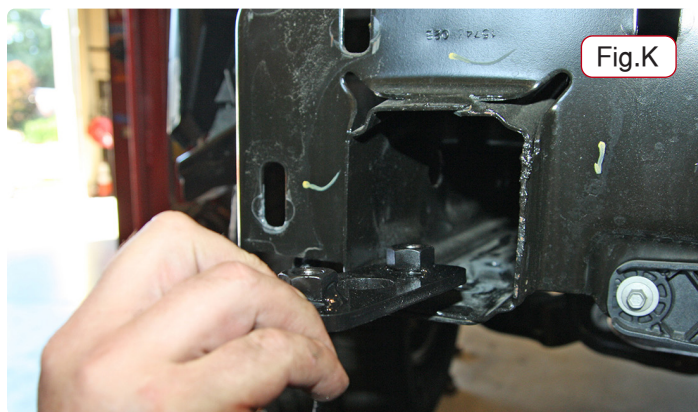
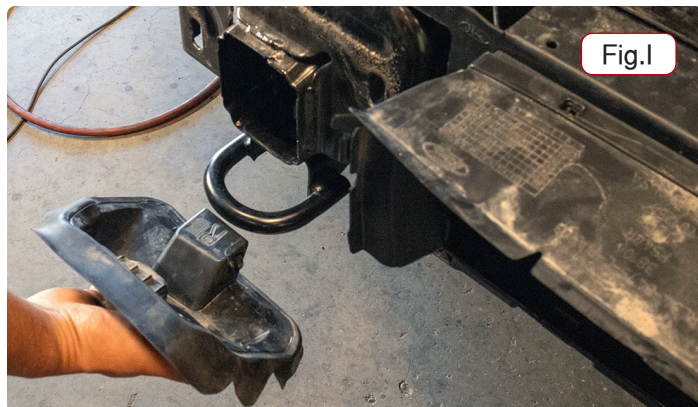

10. On each side, place one of the supplied 1/2" lock washers and some Loctite over one of the 1/2" x 2" grade 8 bolts, and bolt up through the main receiver brace, the frame and into the rear hole of the nutted backing plate. Bolt up through the main receiver brace, the tow hook rail and into the forward hole of the nutted backing plate using a 1/2" x 4" grade 8 bolt with 1/2" lock washer and Loctite (Fig.L).

11. Working on the driver's side only, use the upper mount of the main receiver brace as a template and, using a long 17/32" bit, drill straight through both sides of the frame rail (Fig.M). *Note: Use a piece of metal and extreme caution to avoid drilling into critical engine components.*

12. Apply Loctite Red to a 1/2" x 6" bolt. Place one of the supplied 1/2" plate washers between the upper mount of the baseplate and the frame, over the hole you drilled in the previous step. Push the bolt all the way through the upper mount, the plate washer, the frame, and finish with a 1/2" plate





BASEPLATE KIT INSTALLATION INSTRUCTIONS

KIT# 524477-5

06/2024
RS

ROADMASTER, Inc. 6110 NE 127th Ave. Vancouver, WA 98682 360-896-0407 fax 360-735-9300 www.RoadmasterInc.com

washer, 1/2" lock washer and 1/2" nut (Fig.N, prior page).

13. Once both sides are done, tighten the bolts to the torque spec found at the end of this document.

14. While the bumper fascia is still removed, remove four 10mm nuts from the inner bumper fold (Fig.O).

15. If you are using a BrakeMaster, install the fitting as shown. To mount a Brakeaway switch, bend the tab 90 degrees as shown in Figure O Inset and use the provided 1/4" x 1" whiz bolt and 1/4" whiz nut to attach it to the bracket. Then, place the bracket over the mounts you just exposed in the previous step and replace the bolts. Ensure that the wiring plug rods and the Brakeaway clear both sides of the grille opening before tightening the bolts.

16. Trim the active air shutter housing on the driver's side indicated in Figure P and Insets. Trim the outer section first. Then, trim it flush as shown in Figure P.

17. As indicated in Figures Q1 and Q2, trim the air dam. Trimming about 1/2" for each.

18. Reinstall the fascia, repeating, backwards, the steps to remove it.

19. On each side, insert the removable front arm into the front receiver 90 degrees from its final towing position, depressing the spring-loaded pin against the receiver. Twist back 90 degrees until the spring-loaded pin snaps into place in the notch on the receiver, locking the arm into place in its final towing position.

Important: Please note, it is the owner's responsibility to ensure the locking of the pins before towing. Otherwise, failure of the towing system will result.

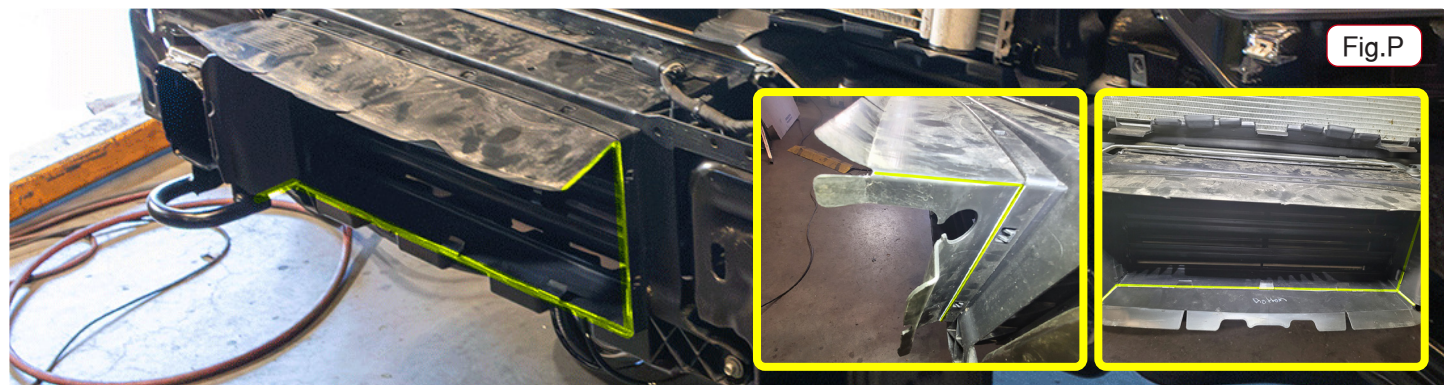
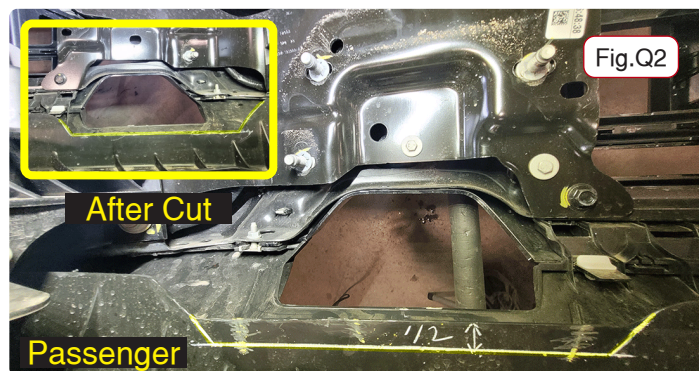
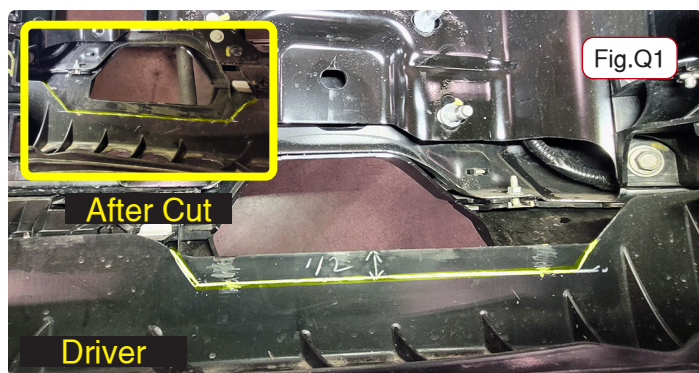
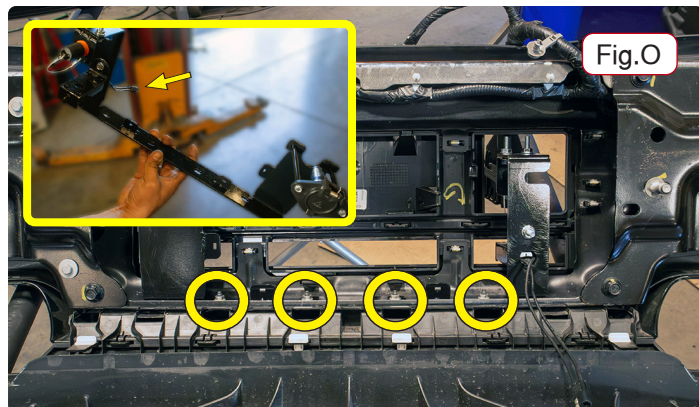



BASEPLATE KIT INSTALLATION INSTRUCTIONS

KIT# 524477-5

06/2024
RS

ROADMASTER, Inc. 6110 NE 127th Ave. Vancouver, WA 98682 360-896-0407 fax 360-735-9300 www.RoadmasterInc.com

Three options for attaching the wiring plug to the main receiver brace

For six-wire plugs: Use the two supplied 3/4" self-tapping screws to attach the electrical plug directly to the rods on the front of the main receiver brace.

For four-wire round plugs: Attach to the plug mounting plate and then use the two supplied 3/4" self-tapping screws to attach the mounting plate to the rods on the front of the main receiver brace.

For four-wire flat plugs: Place the plug through the mounting plug plate, and then secure it using the supplied zip tie on the front of the plug (Fig.Q). Use the two supplied 3/4" self-tapping screws to attach the mounting plate to the rods on the front of the main receiver brace.

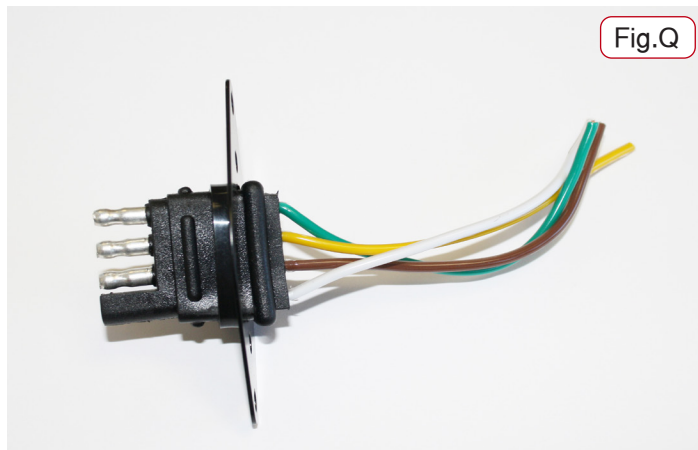

Fig.Q

IMPORTANT!

Safety cables are required by law. When towing, connect safety cables to the safety cable tabs illustrated on the separate insert with the drawing and parts list and in Figure R. Make certain there is adequate slack in the cables to allow a full turning radius; otherwise, damage will result. If necessary, longer cables or cable extensions are available.

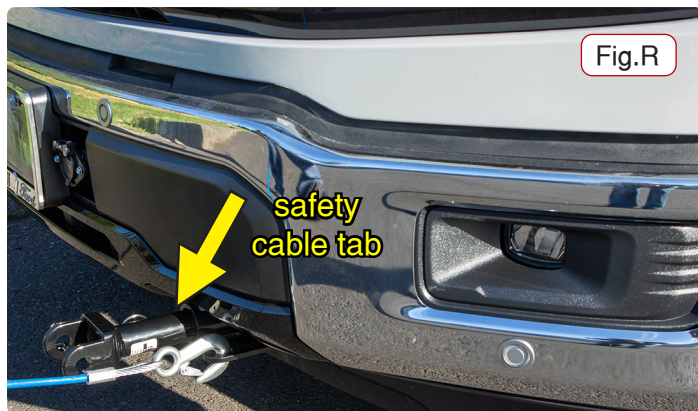

Fig.R

BOLT TORQUE REQUIREMENTS

Note: The torque values represented below are intended as general guidelines. Torque requirements for specific applications may vary. Roadmaster does not warrant this information to be accurate for all applications and disclaims all liability for any claims or damages which may result from its use.

STANDARD BOLTS

Thread Size	Grade	Torque
5/16-18	5	13 ft./lb.
3/8-16	5	23 ft./lb.
7/16-14	5	37 ft./lb.
1/2-13	5	57 ft./lb.
5/8-11	5	112 ft./lb.

METRIC BOLTS

Thread Size	Grade	Torque
6mm-1.0	8.8	6 ft./lb.
8mm-1.0	8.8	18 ft./lb.
8mm-1.25	8.8	16 ft./lb.
10mm-1.25	8.8	36 ft./lb.
10mm-1.5	8.8	31 ft./lb.

METRIC BOLTS

Thread Size	Grade	Torque
12mm-1.25	8.8	64 ft./lb.
12mm-1.5	8.8	60 ft./lb.
12mm-1.75	8.8	55 ft./lb.
14mm-2.0	8.8	88 ft./lb.