



# Front End Link Replacement Kit INSTALLATION INSTRUCTIONS

KIT# 590315-00

04/26  
FC

ROADMASTER, Inc. 6110 NE 127th Ave. Vancouver, WA 98682 360-896-0407 www.RoadmasterInc.com

For Freightliner M2 w/Roadmaster 1 3/4"  
Anti-Sway Bar

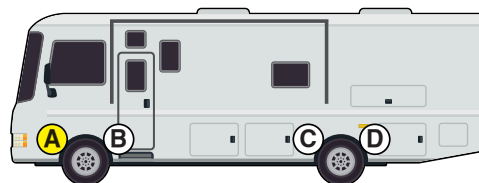

## WARNING

**Failure to follow these instructions can result in property damage, personal injury or even death.**

- If raising the vehicle to install the anti-sway bar, always support the vehicle with jack stands at both frame rails or at the rear axle before working underneath. Ensure that the jack stands are securely positioned, and are rated at or above the weight of the vehicle.
- The installer must read the instructions and use all bolts and parts supplied. Use only the parts supplied by ROADMASTER to install this kit.
- Minor modifications are sometimes necessary due to slight vehicle variations, even for the same year, make and model.
- Regardless of year, make and model, a wide range of options for specific applications may or may not interfere with the installation. It is the installer's responsibility to make certain that equipment is not damaged once the suspension solution travels through the full range of motion. Failure to ensure adequate clearance could result in non-warranty property damage, personal injury or even death.

- If running changes were made by the manufacturer after this kit was designed, there may be weldments, braces, gussets, or other structural items which interfere with the installation. It is the installer's responsibility to allow for these running changes without sacrificing the structural integrity of the anti-sway bar. Failure to securely fasten the anti-sway bar could result in property damage, personal injury or even death.
- ROADMASTER will not be responsible for any damage or injury resulting from any modification or alteration.
- Check ALL the fasteners for tightness before and after road testing the vehicle.
- Do not use this document for custom fabrication, as it may not show all parts or structural components.
- Do not use an air impact wrench when re-installing bolts, as stripped threads may result.
- This anti-sway bar is only warranted for the original installation. Installing a used anti-sway bar on another vehicle is not recommended and will void the warranty.

## Information:

Thank you for purchasing this rear anti-sway bar kit. This kit is designed to improve the handling characteristics of the Freightliner M2; by reducing the body roll and balancing the weight transfer during cornering.

The anti-sway bar kit is engineered for long life and trouble-free performance. For maximum suspension control, use this kit along with our shock absorbers and our front anti-sway bar kit. All the hardware needed for installation is included in this kit. Refer to the PARTS LIST in these instructions to identify the parts.

Before starting the installation, lay out the kit components in order, as they will be used. This will give you a visual idea of how the components work, and will also confirm that everything is present and accounted for.



## BOLT TORQUE REQUIREMENTS

Note: The torque values represented below are intended as general guidelines. Torque requirements for specific applications may vary. Roadmaster does not warrant this information to be accurate for all applications and disclaims all liability for any claims or damages which may result from its use.

### STANDARD BOLTS

Thread Size	Grade	Torque
5/16-18	5	13 ft./lb.
3/8-16	5	23 ft./lb.
7/16-14	5	37 ft./lb.
1/2-13	5	57 ft./lb.
5/8-11	5	112 ft./lb.

### METRIC BOLTS

Thread Size	Grade	Torque
6mm-1.0	8.8	6 ft./lb.
8mm-1.0	8.8	18 ft./lb.
8mm-1.25	8.8	16 ft./lb.
10mm-1.25	8.8	36 ft./lb.
10mm-1.5	8.8	31 ft./lb.

### METRIC BOLTS

Thread Size	Grade	Torque
12mm-1.25	8.8	64 ft./lb.
12mm-1.5	8.8	60 ft./lb.
12mm-1.75	8.8	55 ft./lb.
14mm-2.0	8.8	88 ft./lb.



# Front End Link Replacement Kit INSTALLATION INSTRUCTIONS

**KIT# 590315-00**

04/26  
FC

ROADMASTER, Inc. 6110 NE 127th Ave. Vancouver, WA 98682 360-896-0407 www.RoadmasterInc.com

## What You'll Need

Sockets and Torque Wrench  
General Hand tools

## About this kit

Fits most Freightliner M2 w/Roadmaster 1 3/4" Anti-Sway Bar

Need Help? Call Toll-Free

1-800-669-9690

SEE NOTE.

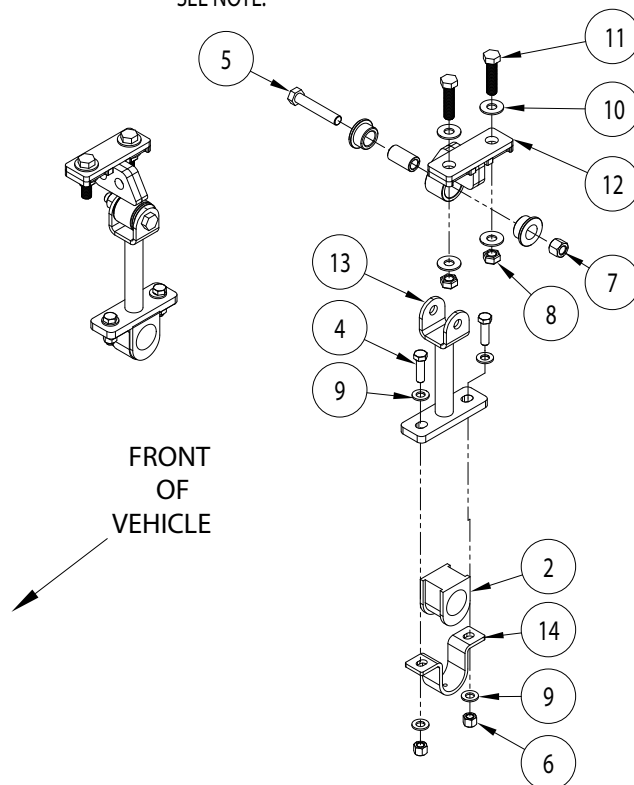

NOTE: INSTALL ITEM 5 IN ITEM 12 BEFORE INSTALLING ITEM 11.

ITEM	QTY	DESCRIPTION	PART
1	4	BUSHING	205209-00
2	2	BUSHING	205220-20
3	2	BUSHING SLEEVE	205503-00
4	4	1/2-13 x 1 3/4" BOLT - GRADE 8	350096-80
5	2	5/8-11 x 3 1/2" BOLT - GRADE 8	350156-00
6	4	1/2-13 NYLON INSERT LOCK NUT	350259-00
7	2	5/8-11 NYLON INSERT LOCK NUT	350263-00
8	4	5/8-11 LOCK NUT	350280-00
9	8	1/2" HARDENED WASHER	350308-80
10	8	5/8" FLAT WASHER	350347-00
11	4	5/8-11 x 2 1/2" BOLT - GRADE 8	350453-50
12	2	BRACKET	B1126
13	2	END LINK	B1127
14	2	BUSHING CLAMP	B141
15	1	THREADLOCKER	200544-00
16	1	AQUALUBE	400011-30

**Important:** All illustrations and specifications contained herein are based on the latest information available at the time of publication approval. ROADMASTER, INC. reserves the right to make changes at any time without notice in material, specification and models or to discontinue models.



# Front End Link Replacement Kit INSTALLATION INSTRUCTIONS

KIT# 590315-00

04/26  
FC

ROADMASTER, Inc. 6110 NE 127th Ave. Vancouver, WA 98682 360-896-0407 www.RoadmasterInc.com

## Installation:

1. Locate the two bolts holding the frame crossmember to the bottom of the frame rails. The crossmember is found just behind the front spring hanger. Remove upper factory end link brackets from frame and hardware.

2. Install bracket (B1126) with the end links already assembled. Ensure bracket is installed in the direction matching the drawing on page 2. The offset goes toward the center of the truck to provide clearance for the leaf springs. Leave the pivot bolt #5 (350156-00) loose at this time to allow for easier assembly.

3. Lube the inside of the D-shaped anti-sway bar bushing with the provided grease. Place the bushings on the bar. Install a bushing clamp (B141) over the bushing. Attach to the bottom of the end link using the supplied bolts (350096-80), washers (350347-00) and nuts (350259-00)(Figure 4).

4. Swing the ends of the anti-sway bar up into the axle brackets. Attach the bar to the brackets using 350158-50 bolts.

5. Now, tighten the drop link pivot bolts to torque specs (Figure 5).

6. Recheck all fasteners and then test drive. Recheck fasteners after the test drive.

**Note:** See next page for more images.

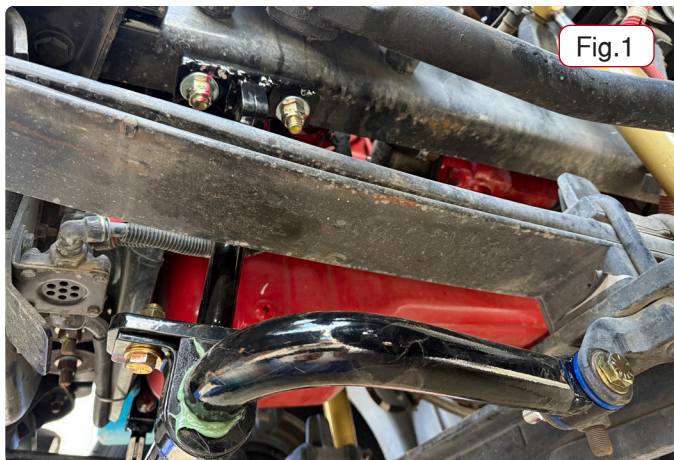

Fig. 1



Fig. 2a



Fig. 2b

## ⚠ WARNING

The anti-sway bar is heavy, and may cause property damage or personal injury if it falls on equipment, engine components or any part of your body. Ensure that the anti-sway bar is supported and that you are out of the way when removing the brackets.

**Failure to follow these instructions may cause property damage, personal injury or even death.**

## ⚠ WARNING

After road testing, re-check all fasteners for proper tightness – if a fastener has worked loose or fallen off, re-tighten or replace it. Without all kit components properly tightened or in place, the anti-sway bar will not stabilize the vehicle at full capacity, which may cause reduced cornering ability or other reductions in vehicle handling or performance.

**Failure to follow these instructions may cause property damage, personal injury or even death.**



# Front End Link Replacement Kit INSTALLATION INSTRUCTIONS

KIT# 590315-00

04/26  
FC

ROADMASTER, Inc. 6110 NE 127th Ave. Vancouver, WA 98682 360-896-0407 www.RoadmasterInc.com



Fig.3



Fig.4

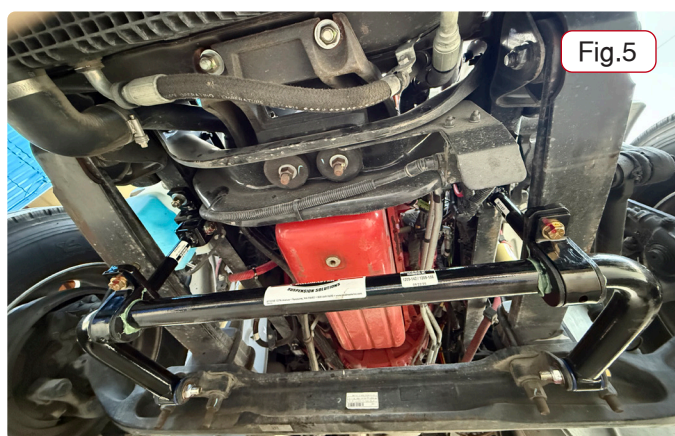

Fig.5

## WARNING

**The anti-sway bar is not a load-bearing component!**

Do not tow or hoist the vehicle using the anti-sway bar or its mounting brackets as attachment points. The anti-sway bar is not designed to carry the weight of the vehicle and may collapse, which will damage the anti-sway bar components, the suspension, or other components. The vehicle will detach or fall, which may cause severe personal injury.

***Failure to follow the instructions in this packet and the warnings therein may result in property damage, personal injury or even death.***