



EXACT CENTER BRACKET KIT INSTALLATION INSTRUCTIONS

KIT# ECB2

85-6348
12-22

ROADMASTER, Inc. 6110 NE 127th Ave. Vancouver, WA 98682 360-896-0407 fax 360-735-9300 www.roadmasterinc.com



See what
this fits

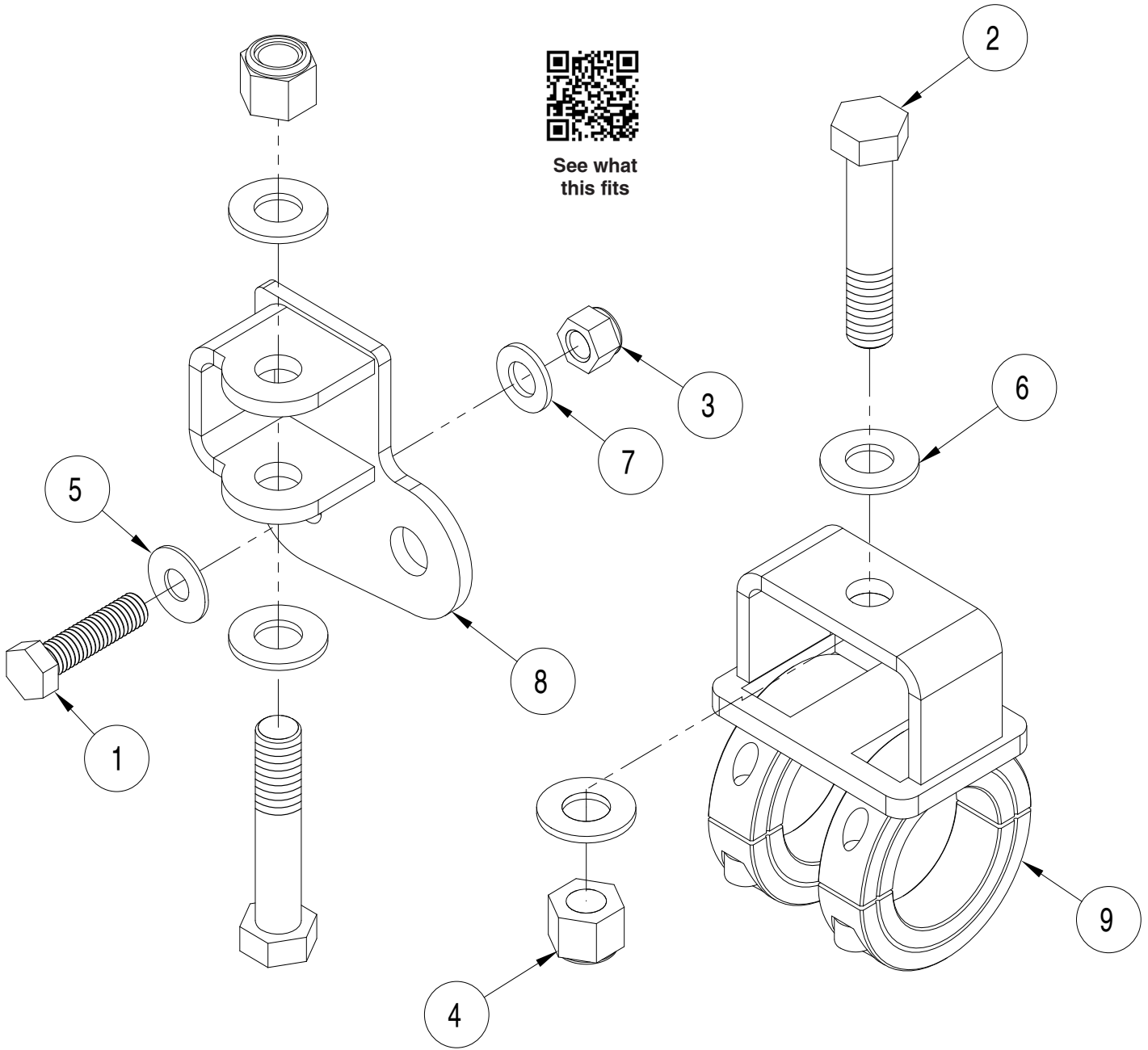

ITEM	QTY	DESCRIPTION	PART NUMBER
1	1	3/8-16 X 1 1/2" BOLT - GRADE 8.....TIGHTEN TO 37 ft-lbs	350057-80
2	2	1/2-13 x 2 1/2" BOLT - GRADE 8.....TIGHTEN TO 25 ft-lbs	350099-80
3	1	3/18-16 NYLON INSERT LOCK NUT	350255-00
4	2	1/2-13 NYLON INSERT LOCK NUT	350259-00
5	1	3/8" HARDENED WASHER	350304-80
6	4	1/2" SAE WASHER	350308-20
7	1	M10 FLAT WASHER	355710-00
8	1	AXLE BRACKET	C003727
9	1	TIE ROD BRACKET, USES 5/16-24" SOCKETTIGHTEN TO 14 ft-lbs	C003728
10	1	LOCTITE	200544-00



EXACT CENTER BRACKET KIT INSTALLATION INSTRUCTIONS

KIT# ECB2

85-6348
12-22

ROADMASTER, Inc. 6110 NE 127th Ave. Vancouver, WA 98682 360-896-0407 fax 360-735-9300 www.roadmasterinc.com

IMPORTANT

Before installing the steering stabilizer, inspect the drag link and tie rod ends, as well as the steering components. If they are excessively worn and/or have excessive play, they will cause handling problems that the steering stabilizer will not fix. Replace worn components before installing the stabilizer to achieve the best results.



Fig.1



Fig.2

1. IMPORTANT! If the tires are not straight ahead, then the vehicle will pull to one side after the installation. To prevent this and further adjustments after the test drive, make sure the steering is truly straight ahead before continuing to step 2. Remove the passenger side track bolt (Fig.1). *Note: It may be necessary to use a ratchet strap to prevent the axle from shifting (Fig.2 and 3).* Retain the track bolt for replacement in the next step.



Fig.3

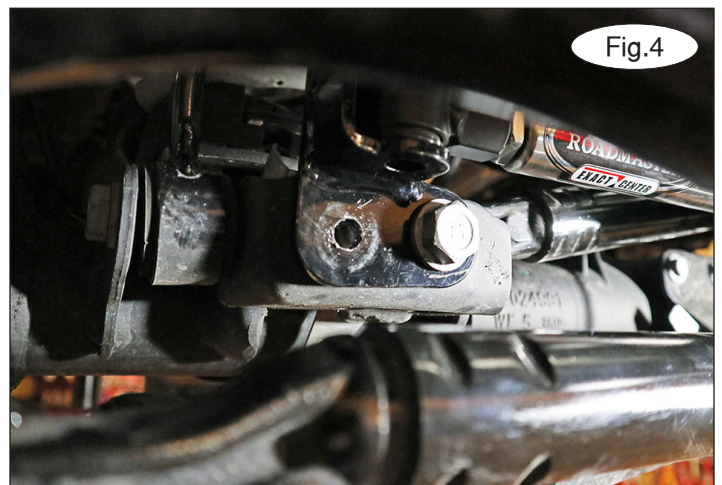

Fig.4

2. Using the factory track bolt you removed in step 1, loosely install the axle bracket in the factory tie rod bolt location, as depicted in Figure 4. *Note: At this point, it may be necessary to adjust the ratchet strap to ensure proper alignment of the track rod bolt hole.*



EXACT CENTER BRACKET KIT INSTALLATION INSTRUCTIONS

KIT# ECB2

85-6348
12-22

ROADMASTER, Inc. 6110 NE 127th Ave. Vancouver, WA 98682 360-896-0407 fax 360-735-9300 www.roadmasterinc.com

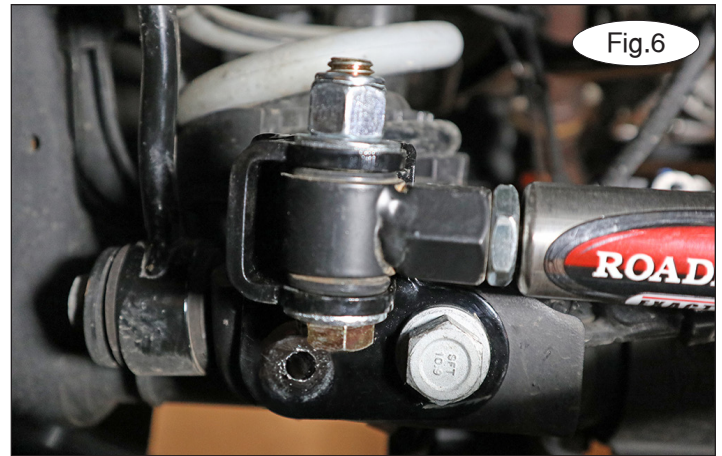
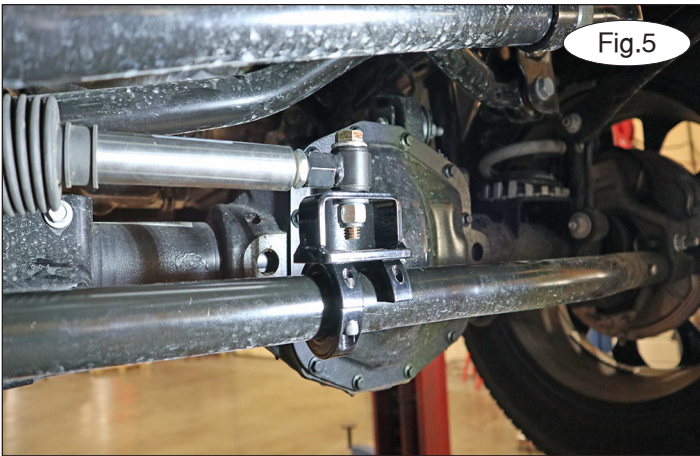

3. Loosely install the tie rod bracket and one split locking collar (Fig.5). Then, using the supplied 1/2" hardware, secure the Exact Center to the tie rod bracket (Fig.5). Now, ensuring that the other end of the unit is well seated in the axle bracket, secure it using the remaining supplied 1/2" hardware (Fig.6).



4. Using the existing hole in the axle bracket as a template, drill a 7/16" hole through the track rod mount (Fig.7). Then, bolt into the hole using the supplied 7/16" hardware (Fig.8).

5. Install the final split locking collar on the tie rod end and secure both collars (Fig.9).

6. Secure the factory track bolt using Loctite Red.

Note: Due to manufacturing variances, the decals may be situated on either the passenger side or the driver's side of the vehicle. This does not impact the product's functionality or how it is installed, as the unit is bi-directional.

Now, ensure that the dust boot is not twisted before proceeding.

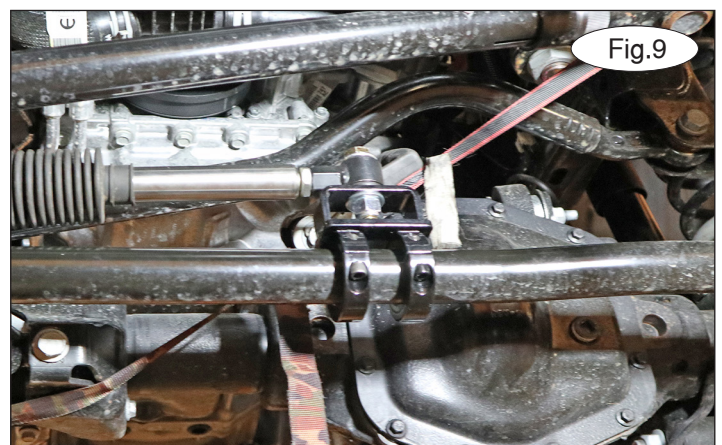



EXACT CENTER BRACKET KIT INSTALLATION INSTRUCTIONS

KIT# ECB2

85-6348
12-22

ROADMASTER, Inc. 6110 NE 127th Ave. Vancouver, WA 98682 360-896-0407 fax 360-735-9300 www.roadmasterinc.com

7. First, ensure that the suspension is loaded. Then, tighten the jam nuts against the ring nuts on each end. **Note: Hold the Exact Center unit in place so that it does not rotate when you tighten the jam nuts. Now, straighten the dust boot.** Test drive the vehicle and ensure that it is not pulling to the left or right. If it needs to be adjusted, follow step 7.

8. **IMPORTANT** Several micro-adjustments may be needed before the fit is dialed in. A left pull can be corrected by shortening the unit; a right pull can be corrected by lengthening the unit. **Important: Only loosen one jamb nut at a time when adjusting. Be sure the jamb nuts are tightened against the END and not the body. Do not exceed a distance of 3/8" between the jamb nut and unit body.**

9. Straighten the dust boot as needed to ensure smooth operation of the unit. **This concludes the installation of the Exact Center.**

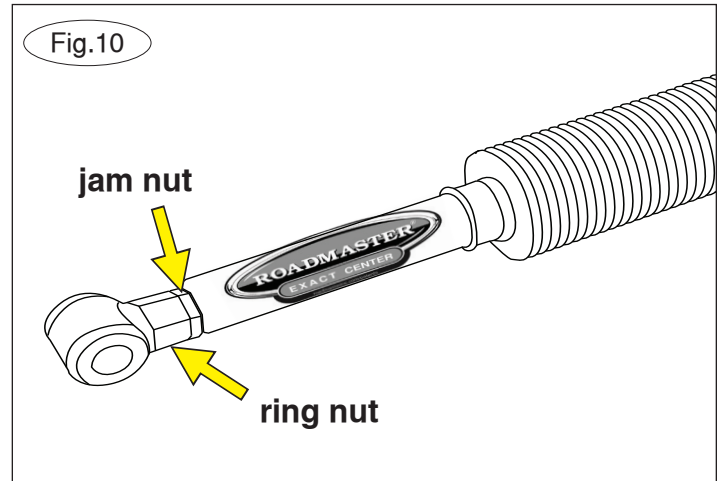

WARNING

Failure to follow these instructions can result in property damage, personal injury or even death.

- Before beginning the installation, ensure that there are not existing steering issues with the vehicle. If there are, correct any deficiencies before installing the Exact Center.
- The installer must read the instructions and use all bolts and parts supplied with the installation kit. Failure to securely fasten the Exact Center could result in loss of the system, damage to the vehicle, personal injury or even death.
- There must be adequate clearance between the Exact Center, mounting kit and all chassis and steering parts or non-warranty damage to the vehicle and/or Exact Center will result. After final installation, recheck and adjust as needed to achieve adequate clearance. Failure to adjust the center positioning may result in loss of vehicular control.
- After installing the Exact Center, any technician performing alignment or suspension work must loosen the tie-rod bracket (if one was included in your vehicle's kit) to adjust the toe.
- Regardless of vehicle, a wide range of OEM or aftermarket options may or may not interfere with the installation. It is the installer's responsibility to make certain that equipment is not damaged once the suspension solution travels through its full range of motion. Failure to ensure adequate

clearance could result in non-warranty property damage, personal injury or even death.

- If running changes were made by the vehicle manufacturer after this kit was designed, some bolts or other fasteners in the included hardware pack may no longer be the correct size. It is the installer's responsibility to verify that the Exact Center is securely fastened to the vehicle, and fitted with the correct hardware, to account for these changes.
- Except to adjust for running changes to the vehicle, use only the parts supplied by ROADMASTER to install the Exact Center. Using standard grade parts or parts of the wrong size may result in loss of the system, damage to the vehicle, personal injury or even death.
- Once a year, the owner must inspect the fasteners for proper tightness.
- ROADMASTER does not recommend using an air impact wrench when reinstalling bolts, as stripped threads may result.
- This Exact Center is only warranted for the original installation. Installing a used Exact Center on another vehicle is not recommended and will void the warranty.

WARNING

Failure to follow these instructions can result in property damage, personal injury or even death.