



STEERING STABILIZER INSTALLATION INSTRUCTIONS

KIT# RBK32

85-6423-00
06-23

ROADMASTER, Inc. 6110 NE 127th Ave. Vancouver, WA 98682 360-896-0407 fax 360-735-9300 www.roadmasterinc.com

Attention: To ensure correct fitment, measure the front axle spring U bolts. **If they are 3/4" diameter: Use RBK8. If they are 7/8": Use RBK32.**

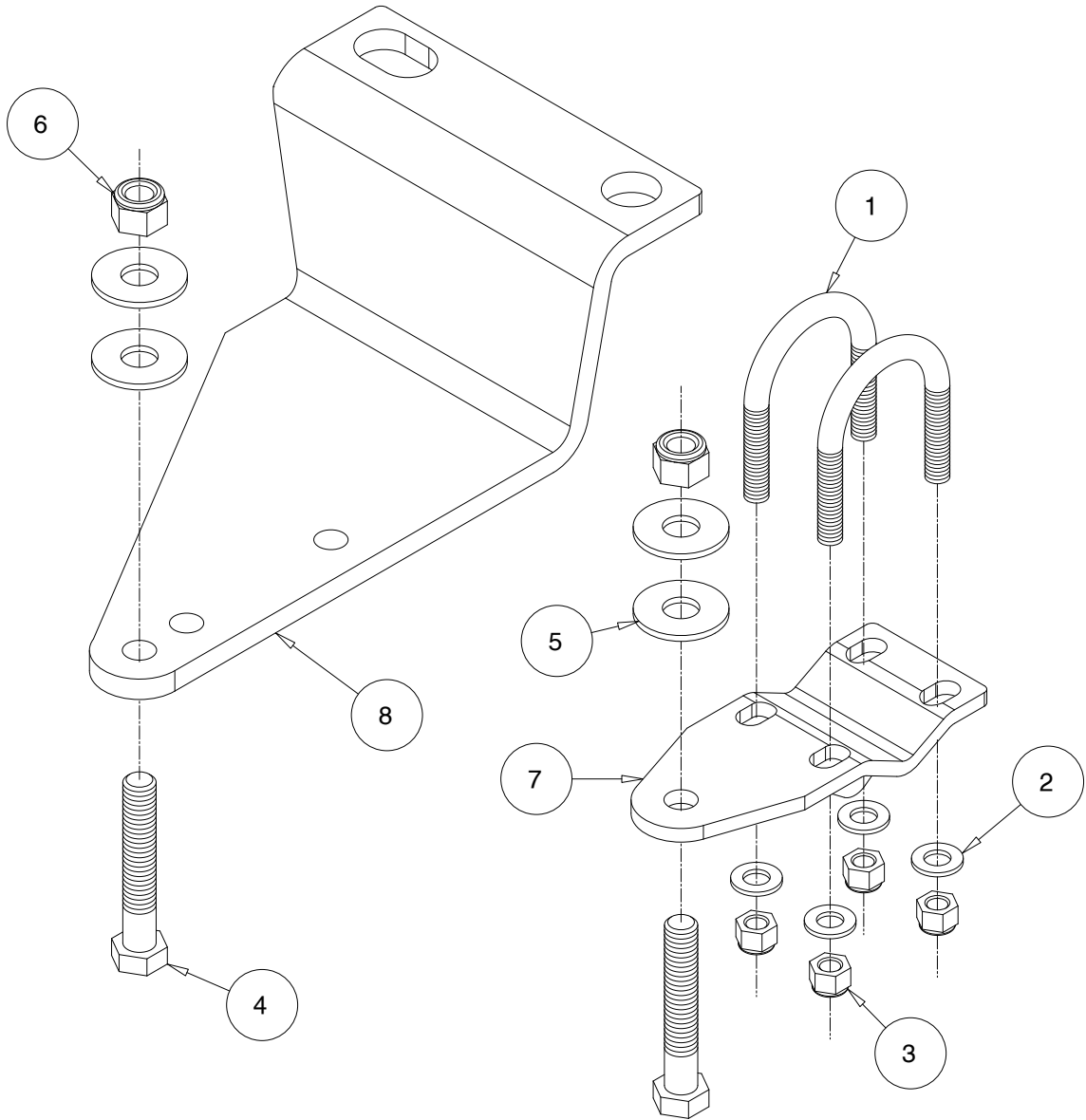

ITEM	QTY	MATERIAL	NAME
1	2	3/8" LARGE U-BOLT	LRG38
2	4	10MM FLAT WASHER	355710-00
3	4	3/8" LOCK NUT	350255-00
4	2	1/2-20 X 3 1/2" GRADE 8 BOLT	350101-60
5	4	1/2" FLAT WASHER	350308-00
6	2	1/2-20 LOCK NUT	350259-01
7	1	TIE ROD BRACKET	B802
8	1	BRACKET	B1104



STEERING STABILIZER INSTALLATION INSTRUCTIONS

KIT# RBK32

85-6423-00
06-23

ROADMASTER, Inc. 6110 NE 127th Ave. Vancouver, WA 98682 360-896-0407 fax 360-735-9300 www.roadmasterinc.com

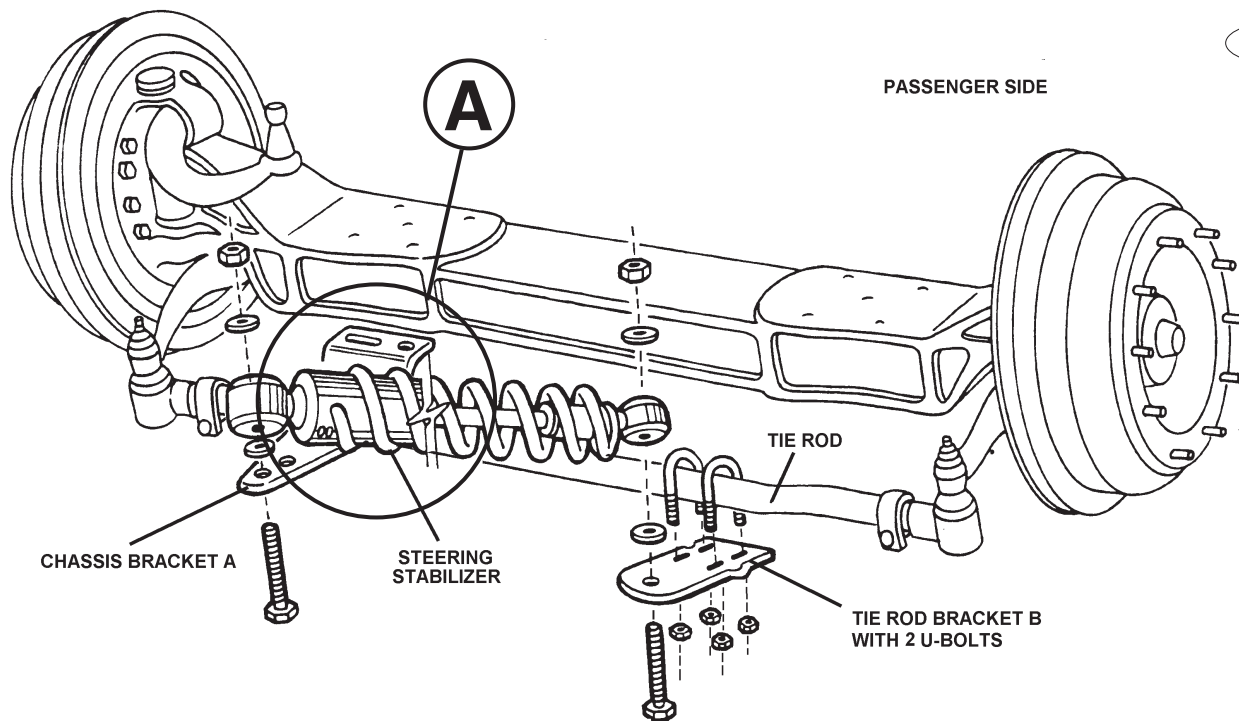

IMPORTANT

Before installing the steering stabilizer, inspect the drag link and tie rod ends, as well as the steering components. If they are excessively worn and/or have excessive play, they will cause handling problems that the steering stabilizer will not fix. Replace worn components before installing the stabilizer to achieve the best results.

WARNING

Failure to follow these instructions can result in property damage, personal injury or even death.

- The installer must read the instructions and use all bolts and parts supplied. Failure to securely fasten the stabilizer could result in loss of the stabilizer, damage to the vehicle, personal injury or even death.
- There must be adequate clearance between the Steering Stabilizer and all chassis and steering parts, and any other components, or non-warranty damage to the vehicle will result. After final installation, the installer must inspect the stabilizer to ensure adequate clearance. Some minor adjustments may be needed to achieve this; always verify that the steering wheel remains centered before and after these adjustments.
- Always test drive the vehicle to confirm the steering wheel settings. If the vehicle pulls to either side, the center positioning must be adjusted. If the steering wheel does not return to the center position, the tie rod bracket may require minor adjustments. Failure to adjust the center positioning may result in a loss of vehicular control.
- After installing this Steering Stabilizer, any technician who is performing alignment or suspension work on the motorhome must loosen the tie-rod bracket to adjust the toe; the technician must also re-adjust the steering damper. Failure to adjust the center positioning may result in a loss of vehicular control.
- Regardless of year, make and model, a wide range of options for specific applications may or may not interfere with the installation. It is the installer's responsibility to make certain that equipment is not damaged once the suspension solution travels through the full range of motion. Failure to ensure adequate clearance could result in non-warranty property damage, personal injury or even death.
- If running changes were made by the vehicle manufacturer after this kit was designed, some bolts or other fasteners in the included hardware pack may no longer be the correct size. It is the installer's responsibility to verify that the stabilizer is securely fastened to the vehicle, and fitted with the correct hardware, to account for these changes. Failure to securely fasten the stabilizer could result in loss of the stabilizer, damage to the vehicle, personal injury or even death.
- Except to adjust for running changes to the vehicle, use only the parts supplied by ROADMASTER to install the stabilizer. Using substandard grade parts or parts of the wrong size may result in loss of the stabilizer, damage to the vehicle, personal injury or even death.
- Once a year, the owner must inspect the fasteners for proper tightness and/or torque, according to the bolt torque requirements chart in these instructions. Failure to securely fasten the stabilizer could result in loss of the stabilizer, damage to the vehicle, personal injury or even death.
- Do not use an air impact wrench when reinstalling bolts, as stripped threads may result.
- This stabilizer is only warranted for the original installation. Installing a used stabilizer on another vehicle is not recommended and will void the warranty.



STEERING STABILIZER INSTALLATION INSTRUCTIONS

KIT# RBK32

85-6423-00
06-23

ROADMASTER, Inc. 6110 NE 127th Ave. Vancouver, WA 98682 360-896-0407 fax 360-735-9300 www.roadmasterinc.com

Note: Roadmaster makes multiple steering stabilizers. The unit depicted in these instructions may vary from your unit but all stabilizers will follow these instructions. If installing a Reflex, ensure that the spring is fully-seated in its track on the collar of the unit. If it is installed without the spring fully-seated in its track, the unit could malfunction or otherwise fail to operate properly (Fig.1 – A, previous page).

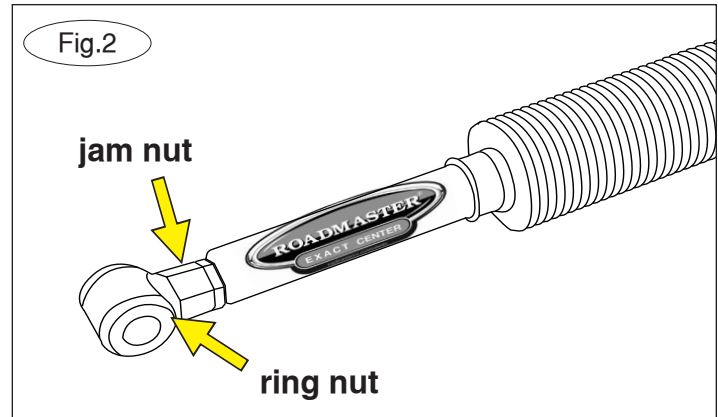

1. Center the steering wheel and lock it into place.

IMPORTANT! If the tires are not straight ahead, then the vehicle will pull to one side after the installation. To prevent this and further adjustments after the test drive, make sure the steering is truly straight ahead before continuing to step 2.

2. Remove the two nuts from the driver's side front axle **spring rear U-bolt**. Install the chassis bracket over the U-bolts, replace the nuts and tighten the assembly. Torque them to the manufacturer's recommendations. *Note:* the bracket must be clear and below the tie rod by 1/4" minimum.

3. Clean the tie rod and loosely install the tie rod bracket toward the passenger side using two 3/8" U-bolts and the four supplied 3/8" lock nuts and 10mm flat washers. Position the tie rod bracket under the tie rod with the steering stabilizer bolt hole toward the rear of the vehicle.

4. Place the stabilizer's bottom end mount on the chassis bracket mounting hole and place the piston rod in the tie rod bracket mounting hole. For installation, orient the bracket as shown above. Adjust the position of the tie rod bracket, if necessary. Place one of the supplied 1/2" flat washers between each mounting bracket bolt hole and stabilizer end mount. Insert one of the supplied 3 1/2" bolts through each steering stabilizer end mount and mounting bracket. Place one of the supplied 1/2" flat washers and 1/2" lock nuts on each mounting bolt and **tighten**. Allow the stabilizer end mounts to rotate easily around the mounting bolts. *Note:* The tie rod bracket should be positioned so that the top end is approximately 1/2" higher than the bottom end (Fig.1, previous page).

5. Tighten the U-bolt lock nuts on the RBK kit. Torque the hardware to approximately 30 ft./lbs.

6. **For Exact Center installations:** First, ensure that the suspension is loaded. Then, tighten the jam nuts against the ring nuts on each end. **Note: Hold the Exact Center unit in place so that it does not rotate when you tighten the jam nuts.** Test drive the vehicle and ensure that it is not pulling to the left or right. If it needs to be adjusted, follow step

7. *Note: Due to manufacturing variances, the decals may be situated on either the passenger side or the driver's side of the vehicle. This does not impact the product's functionality or how it is installed, as the unit is bi-directional.*

Ensure that the dust boot is not twisted before proceeding to the next step.

8. **For Exact Center installations only:** First, ensure that the suspension is loaded. Then, tighten the jam nuts against the ring nuts (Fig.2). **Note: Hold the Exact Center unit in place so that it does not rotate when you tighten the jam nuts.** Test drive the vehicle and ensure it's not pulling to the left or right. If it needs to be adjusted, follow step 9.

9. **IMPORTANT** Several micro-adjustments may be needed before the fit is dialed in. **Important: Only loosen one jam nut at a time when adjusting. Be sure the jam nuts are tightened against the END and not the body. Do not exceed a distance of 3/8" between the jam nut and unit body.**

On installs where the unit is located behind the front axle and fixed to the passenger side with the driver's side of the unit on the tie rod or drag link: A left pull can be corrected by lengthening the unit; a right pull can be corrected by shortening the unit.

On installs where the unit is located behind the front axle and fixed to the driver's side with the passenger side of the unit on the tie rod or drag link: A left pull can be corrected by shortening the unit, a right pull can be corrected by lengthening the unit.

10. Straighten the dust boot as needed to ensure smooth operation of the unit. **This concludes the installation of the Exact Center.**