



Thank you for purchasing our anti-sway bar kit. Please read through these instructions before installation.

# Installation Instructions

## Front Anti-Sway Bar Kit for the Chevy P30

part # 1109-116  
1-5/8" diameter

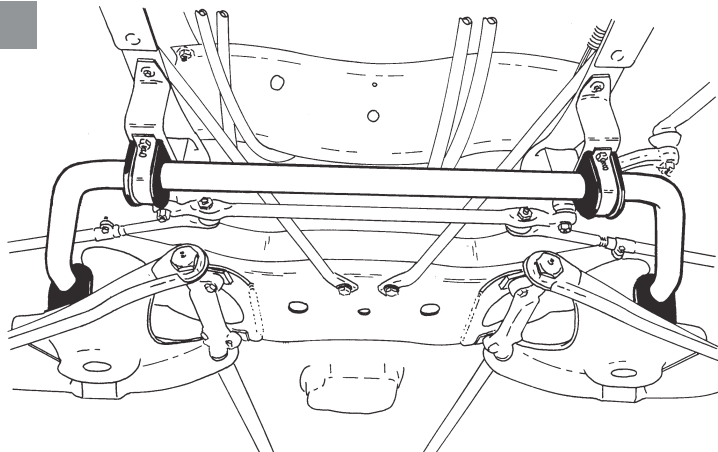

## INTRODUCTION

Thank you for purchasing this anti-sway bar kit. These components are designed to improve the handling characteristics of your Chevy P30 by reducing the body roll and balancing the weight transfer during cornering. The anti-sway bar kit is engineered for long life and trouble-free performance. For maximum suspension control, use this kit along with our rear sway bar kit.

All the hardware needed for installation is included in this kit. Refer to the PARTS LIST in these instructions to identify the parts.

## SUGGESTED TOOLS

The following tools are suggested to complete the installation procedures:

- 9/16" open/box wrench
- 9/16" socket
- Ratchet wrench
- Jack and jack stands (optional)

## WARNING

- If raising the vehicle to install the anti-sway bar, always support the vehicle with jack stands at both frame rails or at the rear axle before working underneath. Ensure that the jack stands are securely positioned, and are rated at or above the weight of the vehicle.
- The installer must read the instructions and use all bolts and parts supplied. Use only the parts supplied by ROADMASTER to install this kit.
- Minor modifications are sometimes necessary due to slight vehicle variations, even for the same year, make and model.
- If running changes were made by the manufacturer after this kit was designed, there may be weldments, braces, gussets, or other structural items which interfere with the installation. It is the installer's responsibility to allow for these running changes without sacrificing the structural integrity of the anti-sway bar. Failure to securely fasten the anti-sway bar could result in property damage,

personal injury or even death.

- ROADMASTER will not be responsible for any damage or injury resulting from any modification or alteration.
- Check ALL the fasteners for tightness before and after road testing the vehicle.
- Do not use this document for custom fabrication, as it may not show all parts or structural components.
- Do not use an air impact wrench when re-installing bolts, as stripped threads may result.
- This anti-sway bar is only warranted for the original installation. Installing a used anti-sway bar on another vehicle is not recommended and will void the warranty.

## WARNING

Failure to follow these instructions can result in property damage, personal injury or even death.

# PARTS LIST

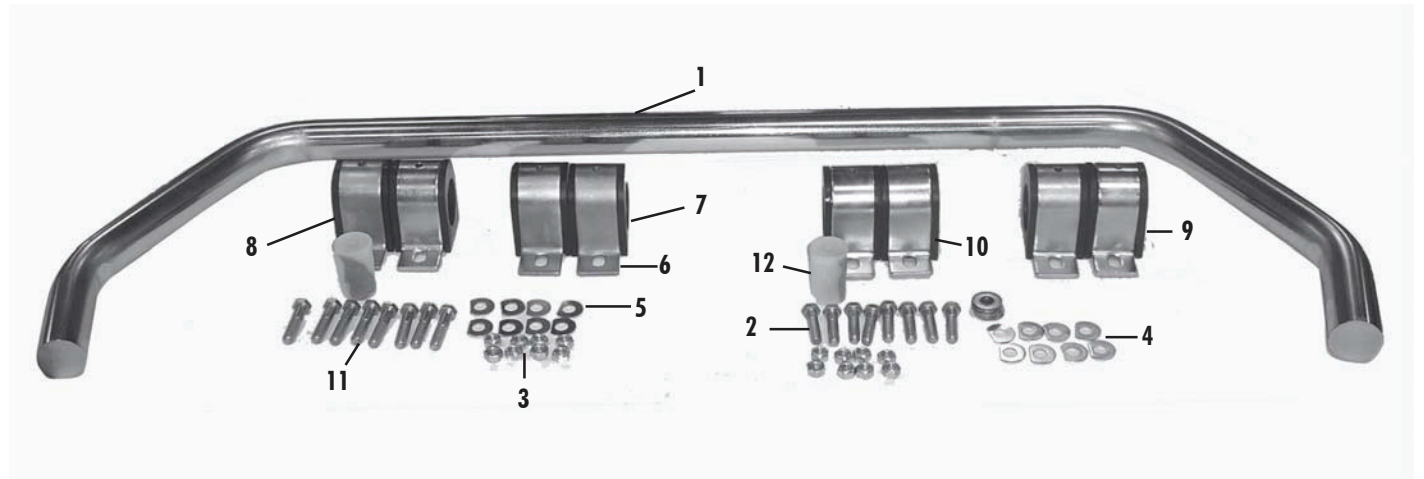

## Part #1109-116

Part #	Description	Qty
1. 580014-00	Sway bar 1-5/8" dia.*	1
2. 350057-80	Bolt, 3/8" x 1-1/2" NC	8
3. 350272-00	Locknut, 3/8" NC	16
4. 350304-80	Washer, 3/8"	16
5. 350304-30	Washer, D shaped	16
6. B140	Bracket, U	8
7. 205222-00	Bushing, poly 1-5/8"	2
8. 205222-10	Bushing, split poly 1-5/8"	2

Part #	Description	Qty
9. 205220-00	Bushing 1-3/4"	2
10. 205220-10	Bushing, split 1-3/4"	2
11. 350058-80	3/8" x 1-3/4" Bolt	8
12. 400011-30	Aqualube Grease	2

\*Not shown

# INSTALLATION

The following instructions must be followed in the order listed to ensure a proper installation and to preserve the ROADMASTER warranty.

## 1. Remove 8 bolts holding sway bar on vehicle.

The anti-sway bar is heavy so use caution when unbolting the brackets that hold it up. Get someone to help you if possible. Loosen brackets on the A arms first, then the frame brackets.

## WARNING

Removing the brackets will release the anti-sway bar. The anti-sway bar is heavy, and may cause property damage or personal injury if it falls on equipment, engine components or any part of your body. Ensure that the anti-sway bar is supported and that you are out of the way when removing the brackets. Failure to follow these instructions may cause property damage, personal injury or even death.

## 2. **Note:** on early models with extra dip in the sway bar:

Early P30 chassis had a dip in the center of the anti-sway bar. If your model had this dip, we suggest wrapping the lower radiator hose with tape to prevent abrasion on the hose.

## 3. Lubricate the bushings with the provided grease.

Put a thorough coat of grease on the inside of each bushing (Figure 1). (For the bushings on the ends of the bar, it's sometimes easier to put the grease on the anti-sway bar, and then slide the bushing over it).

## 4. Place the bushings on the anti-sway bar.

Use the old anti-sway bar to determine the proper location for the bushings. *Note:* the split bushings go on the center of the bar.

## 5. Push the brackets over the bushings.

*Note:* on the old anti-sway bar, the two end brackets go down, and the two center brackets go up.

## 6. Lift the anti-sway bar into place.

Lift the anti-sway bar into place, setting the end brackets onto the A arms. Then, lift the center into place and drop bolts with washers through from the top. Start nuts with D washers onto bolts. Drop the bolts with D washers through the end brackets. Start nuts with washers onto the bolts (Figure 2).

## 7. Center the anti-sway bar and tighten it.

Tighten the bolts halfway. Check the anti-sway bar to be certain it is centered. Now, tighten all bolts evenly (30-35 ft.-lbs. if you have a torque wrench).

Figure 1

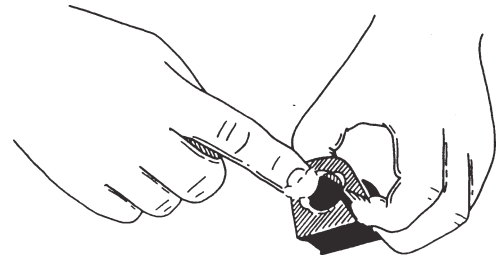
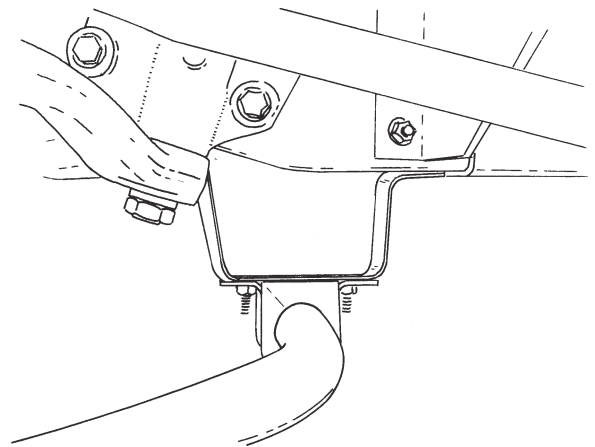

Figure 2



## 8. Test drive the vehicle.



### **WARNING**

After road testing, re-check all fasteners for proper tightness — if a fastener has worked loose or fallen off, re-tighten or replace it. Without all kit components properly tightened or in place, the anti-sway bar will not stabilize the vehicle at full capacity, which may cause reduced cornering ability or other reductions in vehicle handling or performance.

Failure to follow these instructions may result in property damage, personal injury or even death.



### **WARNING**

#### **The anti-sway bar is not a load-bearing component**

Do not tow or hoist the vehicle using the anti-sway bar or its mounting brackets as attachment points. The anti-sway bar is not designed to carry the weight of the vehicle and may collapse, which will damage the anti-sway bar components, the suspension, or other components. The vehicle will detach or fall, which may cause severe personal injury.

Failure to follow these instructions may result in property damage, personal injury or even death.



# Installation Instructions

## Urethane Bushings for 1-3/4" Rear Anti-Sway Bar for Chevy P30 Chassis

part # 1109-116

*Thank you for purchasing our sway bar kit. Please read through these instructions before installation.*

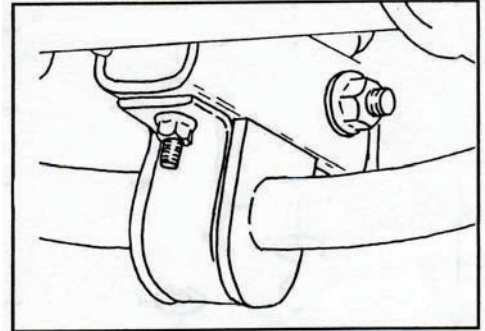

## INTRODUCTION

Thank you for purchasing our urethane bushings. These components are designed to improve the handling characteristics of your Chevy P30 by reducing the body roll and balancing the weight transfer during cornering.

All the hardware needed for installation is included in this kit. Refer to the PARTS LIST in these instructions to identify the parts.

## SUGGESTED TOOLS

The following tools are suggested to complete the installation procedures:

- 9/16" open/box wrench
- Floor or bottle jack
- Knife or razor blades
- Rags or paper towels

## WARNING

- If raising the vehicle to install the anti-sway bar, always support the vehicle with jack stands at both frame rails or at the rear axle before working underneath. Ensure that the jack stands are securely positioned, and are rated at or above the weight of the vehicle.
- The installer must read the instructions and use all bolts and parts supplied. Use only the parts supplied by ROADMASTER to install this kit.
- Minor modifications are sometimes necessary due to slight vehicle variations, even for the same year, make and model.
- If running changes were made by the manufacturer after this kit was designed, there may be weldments, braces, gussets, or other structural items which interfere with the installation. It is the installer's responsibility to allow for these running changes without sacrificing the structural integrity of the anti-sway bar. Failure to securely fasten the anti-sway bar could result in property damage, personal injury or even death.
- ROADMASTER will not be responsible for any damage or injury resulting from any modification or alteration.
- Check ALL the fasteners for tightness before and after road testing the vehicle.
- Do not use this document for custom fabrication, as it may not show all parts or structural components.
- Do not use an air impact wrench when re-installing bolts, as stripped threads may result.
- This anti-sway bar is only warranted for the original installation. Installing a used anti-sway bar on another vehicle is not recommended and will void the warranty.

## WARNING

**Failure to follow these instructions can result in property damage, personal injury or even death.**

# PARTS LIST

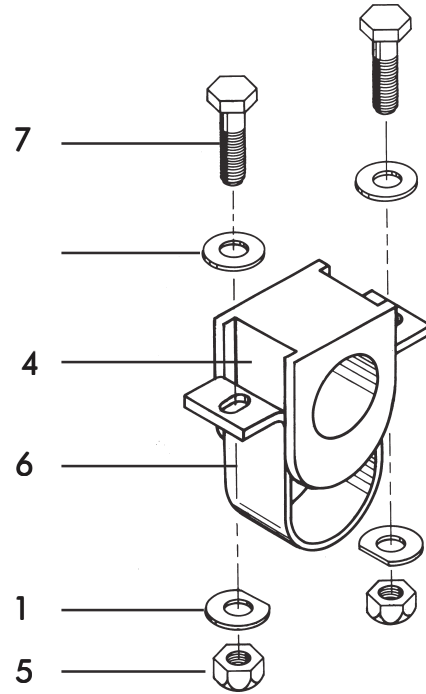
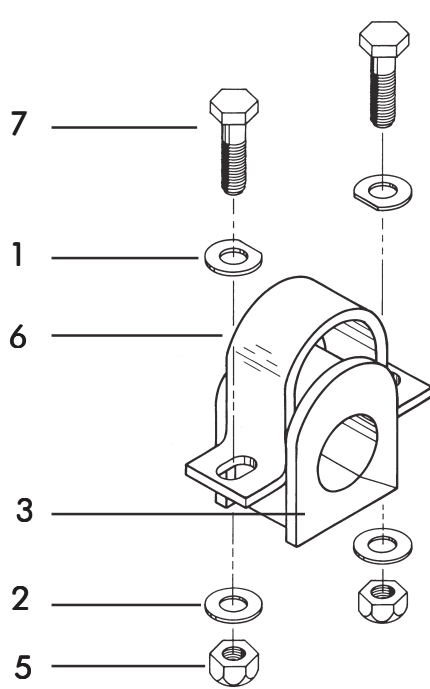

## Part #1109-116

Part #	Description	Qty
1. 350304-30	Washer, D shaped	8
2. 350304-80	Flat washer	8
3. 205220-00	Urethane bushing, split	2
4. 205220-10	Urethane bushing	2
5. 350225-00	Locknut, 3/8"	8
6. B140	Saddle bracket	4
7. 350057-80	Bolt, 3/8" x 1-1/2"	8
8. 400011-30	AQUALUBE Grease	1

### Free Extended Warranty

You must accurately and completely fill out and mail the product registration card within thirty (30) days from the date of purchase to qualify for your warranty. **If we receive your card, completely and accurately filled out, within twenty (20) days from the date of purchase, we will extend the coverage to a total of two (2) years at no extra charge.**

Your product registration is an important record for ROADMASTER to keep in touch with you. It also enables us to expedite any future claim, update or recall that may arise concerning our products.

# INSTALLATION

*The following instructions must be followed in the order listed to ensure a proper installation and to preserve the ROADMASTER warranty.*

1. Lubricate the solid urethane bushing (Figure 1) and push it over the end of the anti-sway bar and slide it into place. Now, push the new saddle bracket over the solid bushing (2 above). This may require tapping on it with a hammer. Bolt the bushing and bracket into place, leaving the bolts loose. Repeat steps 1 and 2 on the other end of the anti-sway bar.
2. Move to the inner bushings. Place the jack under the center of the anti-sway bar so it can be lowered and raised easily.
3. Remove 3/8" bolts and saddle brackets. Now, make a cut through the original rubber bushing using a knife or razor blade. Remove the original bushing.
4. Lubricate the urethane bushing and slide it over the anti-sway bar into place (#1 above). Push the bracket over the bushing and tap into place, if necessary. Start the bolts, making certain the D washers (350304-30) fit against the new brackets.
5. Once you have all the bushings and brackets in place, tighten all bolts to 25-30 ft.-lbs.
6. Remove jack and all original parts and pieces from under the coach or truck.
7. Test drive and listen for noise.



## WARNING

After road testing, re-check all fasteners for proper tightness — if a fastener has worked loose or fallen off, re-tighten or replace it. Without all kit components properly tightened or in place, the anti-sway bar will not stabilize the vehicle at full capacity, which may cause reduced cornering ability or other reductions in vehicle handling or performance.

Failure to follow these instructions may result in property damage, personal injury or even death.

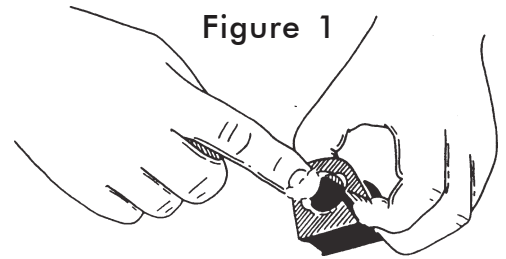

Figure 1